

CONTRACTOR RIG RACK

PACE EDWARDS RETRACTABLE HARD TRUCK BED COVER & UTILITY RACK SYSTEM









STANDARD INSTALLATION INSTRUCTIONS







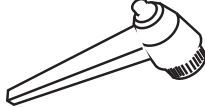



IMPORTANT! The Pace Edwards truck bed cover and Explorer Series Rails **MUST** be installed on the truck first before attempting to install this rack system!

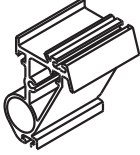

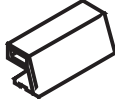





CONTRACTOR RIG CROSSMEMBER BOX CONTENTS:

 <p>TRUSS CROSSMEMBER (x2)</p>		 <p>EXT. BEAM CROSSMEMBER (x1)</p>		
 <p>REAR CROSSMEMBER TRUSS PLASTIC LOW FRICTION INSERT (x1)</p>		 <p>CROSSMEMBER TRUSS RUBBER ANTI-WEAR INSERTS (x3)</p>		
 <p>1" CARRIAGE BOLTS (x6)</p>	 <p>5/16" STAINLESS LOCK WASHERS (x6)</p>	 <p>5/16" STAINLESS LOCK NUTS (x6)</p>	 <p>3/8" ADJUSTABLE HANDLES (x2)</p>	 <p>5/16" KNOB (x2)</p>

CONTRACTOR RIG LEG BOX CONTENTS:

 <p>HEAVY GUSSETS (x 4)</p>	 <p>LEGS (x4)</p>	 <p>TRUSS MOUNTS (x4)</p>	 <p>BRACES (x 4)</p>	
 <p>5" CARRIAGE BOLTS (x 12)</p>	 <p>3/8" LOCK NUT (x12)</p>	 <p>1" CARRIAGE BOLTS (x24)</p>	 <p>5/16" STAINLESS LOCK WASHERS (x24)</p>	 <p>5/16" STAINLESS LOCK NUTS (x24)</p>

CONTRACTOR RIG EXTENSION BEAM BOX CONTENTS:

 <p>EXTENSION BEAM HALVES (x4)</p>				
 <p>4-3/8" STAINLESS BOLTS (x 4)</p>	 <p>3/8" STAINLESS NUT (x4)</p>	 <p>3/8" STAINLESS FLAT WASHERS (x8)</p>	 <p>3/8" STAINLESS LOCK WASHERS (x4)</p>	 <p>PARALLELOGRAM DECALS (x2)</p>

A General Note on Assembly:

These parts have been precision cut to tolerances as close as one thousandth of an inch. Some fits are designed to be press fits, others are designed to be sliding fits; but nowhere should the use of great force be required for assembly. As with any piece of machined equipment, if a part is not fitting as it should, don't use excessive force, identify the problem and correct it. An initial misalignment of two parts can cause a burr on one of them and make smooth assembly difficult.

INSTALL TIP!

INSTALL TIP!

STEP 1: INSTALL EXTENSION BEAM MOUNTING BOLTS

HARDWARE USED:



1" CARRIAGE BOLTS x 4

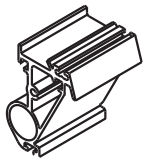

HEAVY GUSSETS x 4

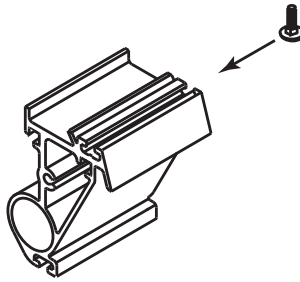

Slide 1" Carriage bolt into the T-slot of the gusset as shown above.

STEP 2: ASSEMBLE LEGS & GUSSETS

HARDWARE USED:

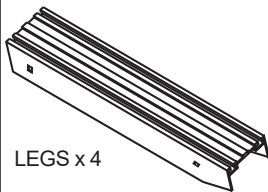

LEGS x 4



5" CARRIAGE BOLTS x 4



3/8" LOCK NUTS x 4

Install gussets into legs as shown until holes align, then slide the 5" carriage bolts through the holes. Install the 3/8" lock nuts on the 5" carriage bolts and tighten with a 9/16" wrench until they bear lightly (do not tighten yet) on the aluminum surface.

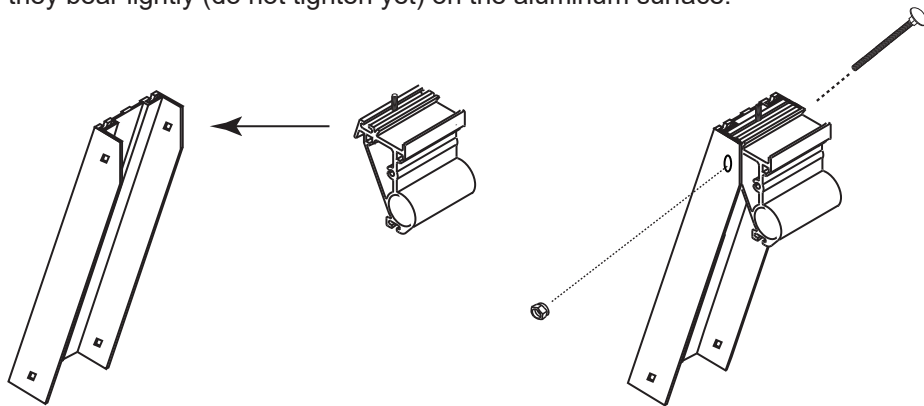

STEP 3: ASSEMBLE CROSSMEMBERS

HARDWARE USED:

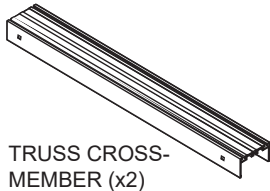

TRUSS CROSS-MEMBER (x2)

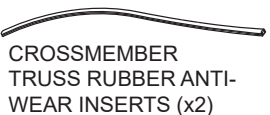

CROSSMEMBER TRUSS RUBBER ANTI-WEAR INSERTS (x2)



REAR CROSSMEMBER TRUSS PLASTIC LOW FRICTION INSERT (x1)



1" CARRIAGE BOLTS x 4

Slide a rubber anti-wear insert into the forward T-slot of each crossmember and slide a plastic low-friction insert into the **REAR** T-slot on the **REAR** crossmember. Slide 2 small carriage bolts (to be used for braces) into the T-slot on the underside of each crossmember.

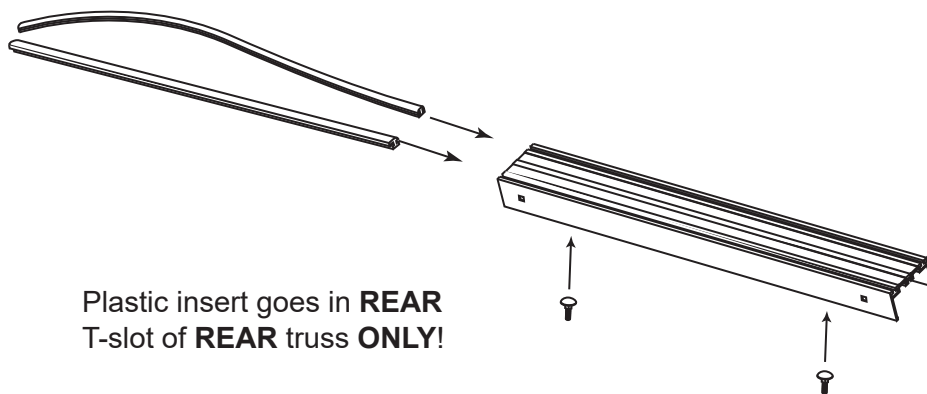

Plastic insert goes in **REAR** T-slot of **REAR** truss **ONLY!**

STEP 4: ASSEMBLE CROSSMEMBERS, LEGS & BRACES

HARDWARE USED:



5" CARRIAGE BOLTS (x 4)



3/8" LOCK NUT (x 2)

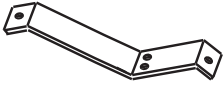

BRACES (x 4)



1" CARRIAGE BOLTS (x 12)



5/16" STAINLESS LOCK WASHERS & NUTS (x 12)

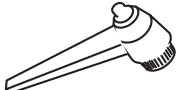

3/8" ADJUSTABLE HANDLES (x2)



5/16" KNOB (x2)

Install crossmember on gusset as shown, and fasten loosely with 5" long carriage bolts and 3/8" locknuts. For the rear crossmember of Contractor Rigs use the 2 adjustable handles provided in the crossmember box. Use the 5/16" knob to fasten the brace under the rear crossmember.

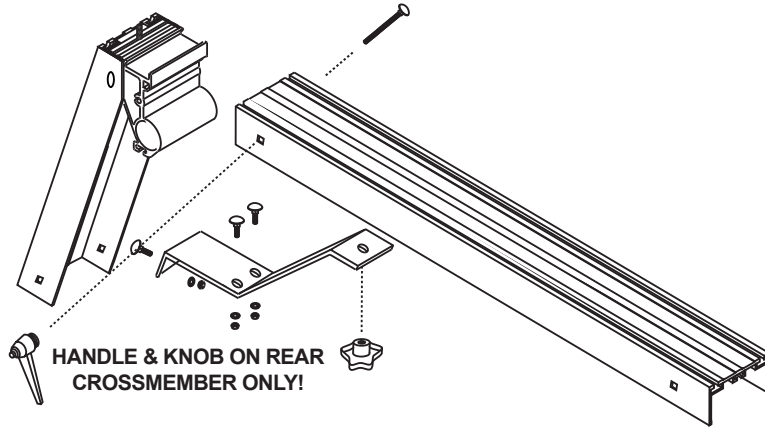

Slide 2 small carriage bolts into the T-slot at the bottom of the gusset and slide 1 carriage bolt into the inside T-slot of the leg and install the brace between the leg and the crossmember using nuts and lock washers.

STEP 5: INSTALL TRUSS MOUNTS ON EXPLORER SERIES RAILS

HARDWARE USED:



1" CARRIAGE BOLTS (x 8)



5/16" STAINLESS LOCK WASHERS & NUTS (x 8)

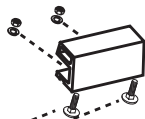

TRUSS MOUNTS (x4)

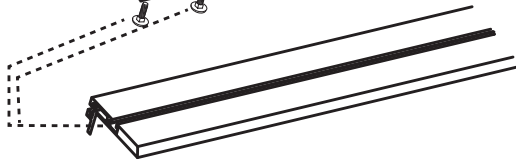

Slide two 1" carriage bolts into the upper T-slots on each end of both Rails. Place a truss mount on each of the bolt pairs (truss mount should be leaning inward as shown), positioning the mounts 1/8" in from the ends of the rails. Install lock washers and nuts and tighten with a 1/2" open end wrench.

STEP 6: INSTALL PICKUP TRUSSES ON TRUSS MOUNTS

HARDWARE USED:



5" CARRIAGE BOLTS (x 4)



3/8" LOCK NUT (x 4)

Lower the truss onto the truss mounts and slide the 5" long carriage bolts through the leg and mount. Install nuts and tighten with a 9/16" wrench until they bear LIGHTLY on the aluminum surface. Make sure that the truss is centered on the rails and that the visible joint between the leg and crossmember is as tight as possible, then tighten all 5" carriage bolts firmly. Note that the truss mount has an elongated hole for side-to-side adjustment of the truss legs. Tighten the nuts and knobs that secure the braces

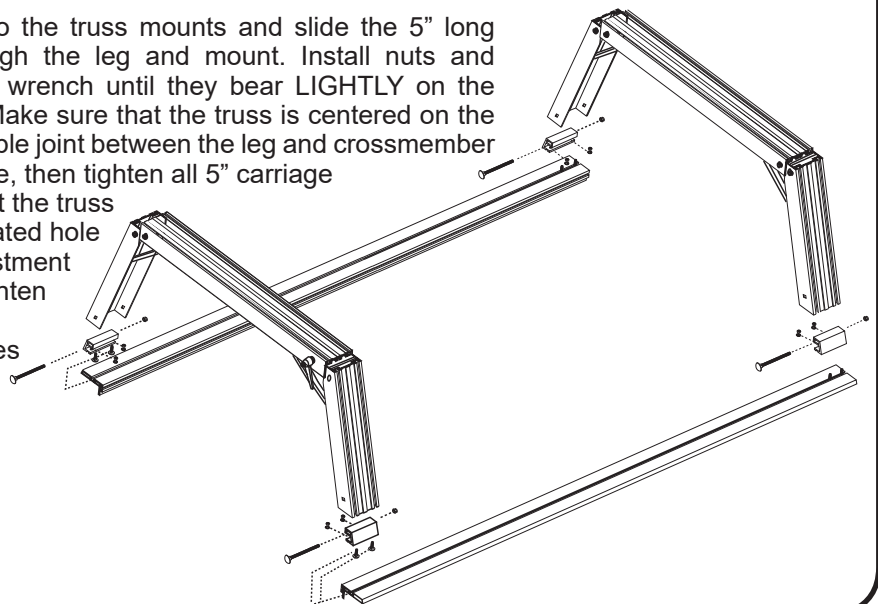

STEP 7: ASSEMBLE EXTENSION BEAM HALVES

HARDWARE USED:

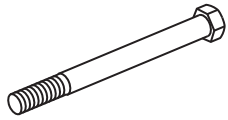

4-3/8" STAINLESS BOLTS (x 4)



3/8" STAINLESS FLAT WASHERS (x4)



3/8" STAINLESS LOCK WASHERS (x8)



3/8" STAINLESS NUT (x4)

You will need a smooth clean surface where you can bolt together the halves of the Extension Beams (ie. cardboard, paper, plastic).

Locate a matching pair of Extension Beams (all holes leaning the same way) and place them end to end so that the welded-in splice blocks touch each other and the holes in the splice blocks align. Slide a 3/8" flat washer on the 4" bolt and insert the bolt through the splice blocks, then install a flat washer, then lock washer, then nut, in that order. Repeat the procedure for the other hole, align Extension Beam halves so that the outside surfaces meet smoothly, and then tighten nuts. Repeat the procedure for the remaining Extension Beam.

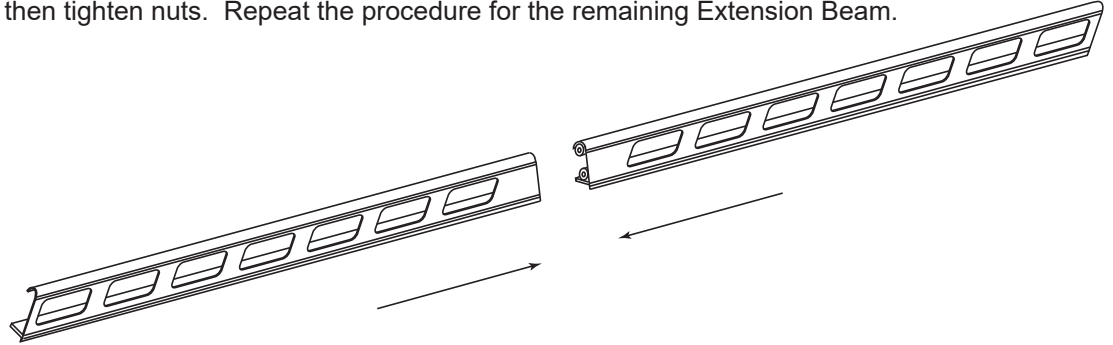

STEP 8: INSTALL DECAL OVER SPLICE JOINTS

HARDWARE USED:



PARALLELOGRAM DECALS (x2)

Important! There are left and right decals! Decal leans forward just like Extension Beam holes do!

Position the decal accurately so that it repeats the punched hole pattern. Although the decal can be installed dry, the "wet method" makes the job much easier. Just add 10 or 12 drops of dish washing liquid to a glass of water, pull off the decal backing, wet the decal and the Extension Beam and apply the decal centered between holes over the splice joint. This wet method allows you to slide the decal around to position it correctly. When correctly positioned, force out excess water with fingers or a sponge. The decal will ultimately adhere with just as much "grip" as the dry method would but without the risk of misalignment, bubbles, creases etc.

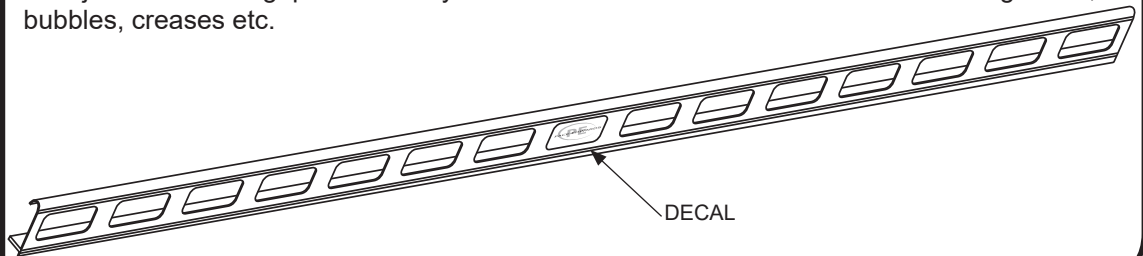

STEP 9: INSTALL EXTENSION BEAMS ON TRUSSES

HARDWARE USED:



5/16" STAINLESS LOCK WASHERS (x 8)



5/16" STAINLESS NUTS (x 8)

Mount one Extension Beam on the Trusses (notched end goes in front), aligning the end of the beam with the rear surface of the rear Truss.

Install lock washers and nuts and tighten these two Extension Beam mounting bolts. Set the other Extension Beam on the opposite side and loosely install a lock washer and nut on the rear Truss only, as you will need to lift the forward end slightly off the front truss to assemble the crossmember.

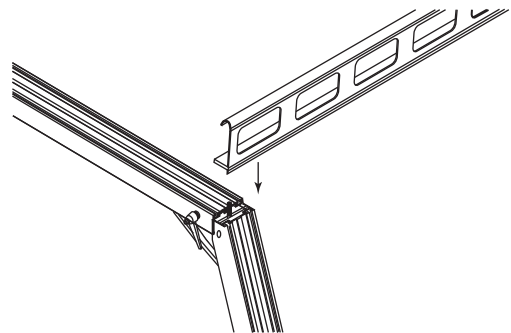

STEP 9: INSTALL CROSSMEMBER

HARDWARE USED:



1" CARRIAGE BOLTS (x 8)



5/16" STAINLESS LOCK WASHERS (x 8)



5/16" STAINLESS NUTS (x 8)

Install the rubber wear strip in the crossmember. With the aid of another person on the opposite side of the truck, hand the correct end of the crossmember over (see drawing) and insert the tab of the Extension Beam inside the crossmember (lifting unbolted end of the Extension Beam is helpful in crossmember assembly). Make sure the Extension Beam and the crossmember are seated and install a 1" carriage bolt downward through each end of the crossmember, then install lock washers & nuts and tighten.

Complete the installation of the Extension Beam (which was left loose). It is normal to experience some degree of effort installing the Extension Beam over the bolt on the front truss on some models due to a tapering truck body.

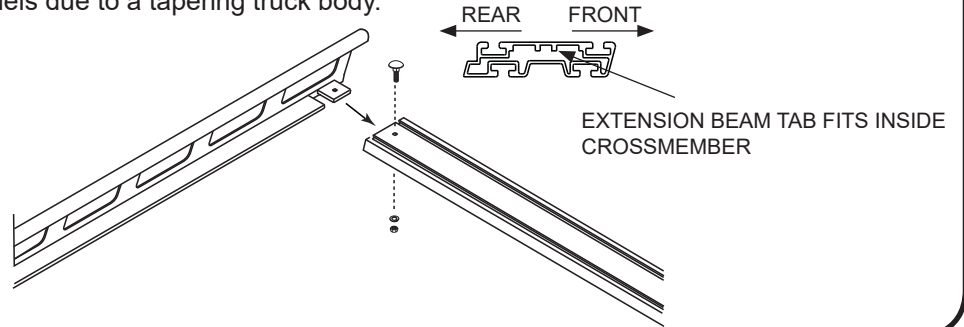







WORK WINCH™

INTEGRATED TIE-DOWN SYSTEM (INCLUDED WITH CONTRACTOR RIG RACK)

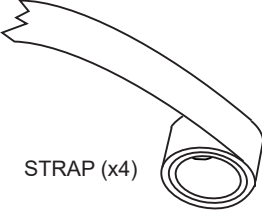
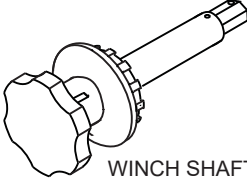
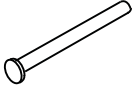
STANDARD INSTALLATION INSTRUCTIONS

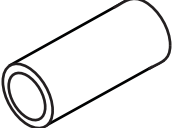
The Work Winch is installed on Contractor Rig rack after the entire rack has been assembled and installed. 4 Work Winches are included with the Contractor Rig Rack and can be installed with the winch on the right and handle on the left or it can be installed with the winch on the left and the handle on the right (a mirror image).

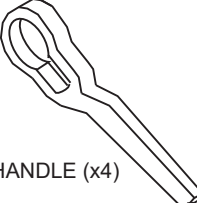
WORK WINCH BOX CONTENTS:

 STRAP (x4)	 WINCH SHAFT (x 4)	 CLEVIS PIN (x4)	 PAWL (x4)	 COTTER PIN (x 4)
 PVC BEARING (x 4)	 LARGE WASHER (x8)	 HANDLE (x4)	 SMALL WASHER (x4)	 LYNCH PIN (x 4)

STEP 1: INSTALL WORK WINCH IN GUSSET

Slide 1 of the 2 large washers onto the winch shaft. Then install the PVC bearing, then insert the assembly halfway into the hole in the gusset.

Orient the pawl (which is shaped like a dolphin) so that its nose is facing away from you and slide the 2" clevis pin through the pawl and into the small hole above the winch shaft.

Slide the winch the rest of the way into the hole. Install the other large washer and then the cotter pin. Hold onto the winch take-up wheel and spread the cotter pin with a pair of pliers.

The handle can be installed or left in a tool box or other accessible place. If it is to be installed, place the handle over the hex, install the smaller washer and then insert the lynch pin and lock it.

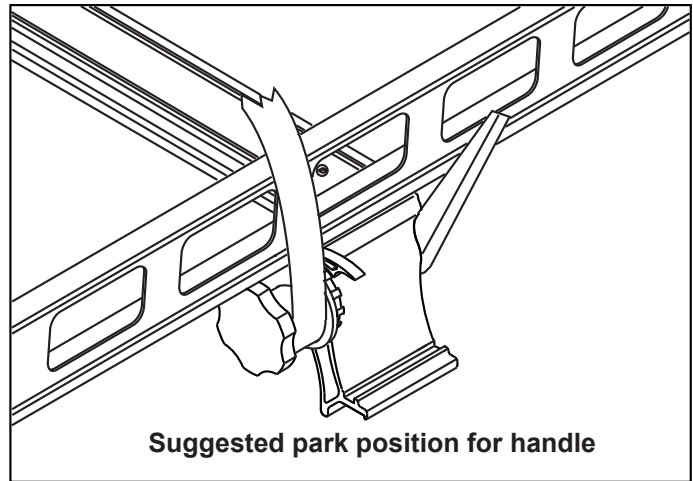

If handle is to be kept on winch shaft, engage as shown to prevent swinging and wear

STEP 2: INSTALL THE STRAP

Insert 6" of the strap end into the slot in the mandrel and wind in a direction so that the top of the spool comes toward you (If the handle has been installed, disengage it from its upper position and let it hang freely so the hex can rotate within it). If the pawl is installed correctly, this is the only direction you will be able to turn the winch without lifting the pawl.

STEP 3: INSTALLATION DETAIL & DRAWING

Work Winches can be installed from either the left side or the right side of Contractor Rig gussets and brackets. Pay careful attention to the orientation of both the pawl and the strap. The pawl looks like a dolphin and its nose faces away from you. The hook end of the strap should come up on the outside of the coil from underneath.

LEFT HAND WINCH INSTALLATION

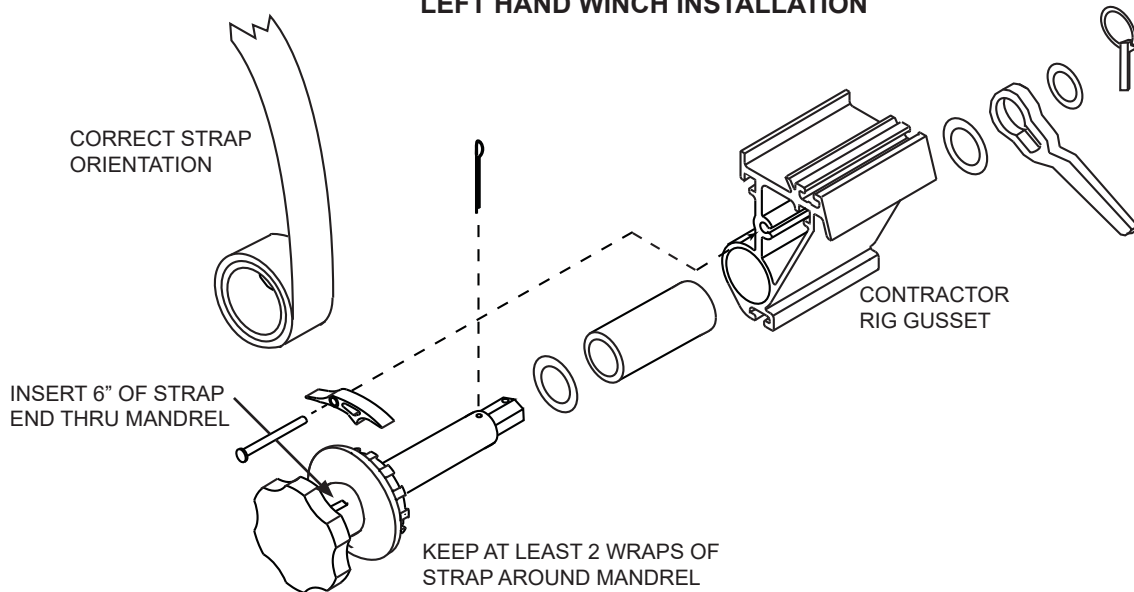

RIGHT HAND WINCH INSTALLATION

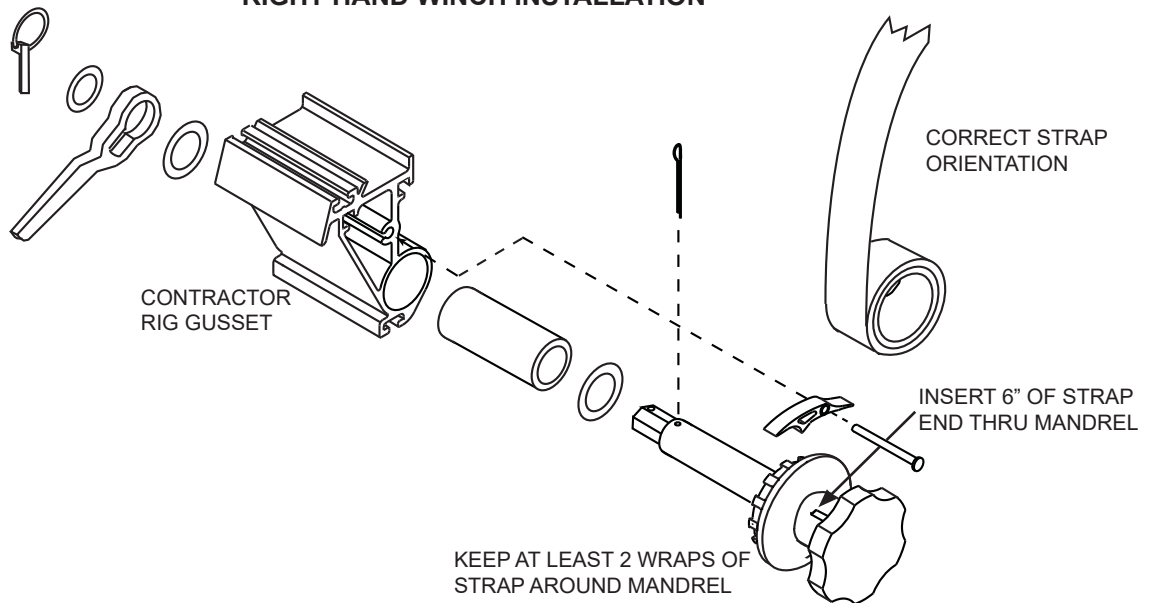

OPERATION & CAUTIONS

To secure a load, let the handle hang freely, lift the pawl and pull out enough strap to go over the load. For pickup trucks, engage the hook on the underside of the 2 1/2" tall lip of the crossmember. Take up the slack by rotating the hand wheel and tighten using the handle. Do not over tighten as the handle has been designed to slip on the hex if it is over-stressed. **REMEMBER TO CHECK STRAP TENSION FREQUENTLY BECAUSE STRAPS STRETCH AND LOADS SETTLE.**

The Work Winch has a rated capacity of 1200 lbs. This is the load the complete assembly will withstand before failure. It is a recommended industry standard that the working load not exceed 1/3 of the rated capacity or 400 lbs.

Inspect strap and winch assembly before each use and replace if worn or damaged. Make sure that the cotter pin and washers are securely in place and that parts move freely. Keep at least 2 wraps of strap around mandrel. Keep strap away from sharp or hot surfaces. **CHECK TENSION FREQUENTLY - STRAPS STRETCH AND LOADS SETTLE.** No warranty is made about the suitability of this product for any purpose other than securing ladders. Keep cargo height within the side rails of the rack

UTILITY RIG RACK

PACE EDWARDS RETRACTABLE HARD TRUCK BED COVER & UTILITY RACK SYSTEM

STANDARD INSTALLATION INSTRUCTIONS



IMPORTANT! The Pace Edwards truck bed cover and Explorer Series Rails **MUST** be installed on the truck first before attempting to install this rack system!



TOOLS REQUIRED FOR ASSEMBLY:

9/16" wrench or socket Flat clean surface (such as cardboard paper or plastic)
1/2" open ended wrench Silicone sealant (if necessary)

BEFORE YOU START:

Read the instructions carefully before you start. These instructions are written for one-person installation. We have noted where briefly having an extra person's assistance can make installation easier.

IMPORTANT! The Pace Edwards truck bed cover and Explorer Series Rails **MUST** be installed on the truck first before attempting to install this rack system!

UTILITY RIG RACK ILLUSTRATION:

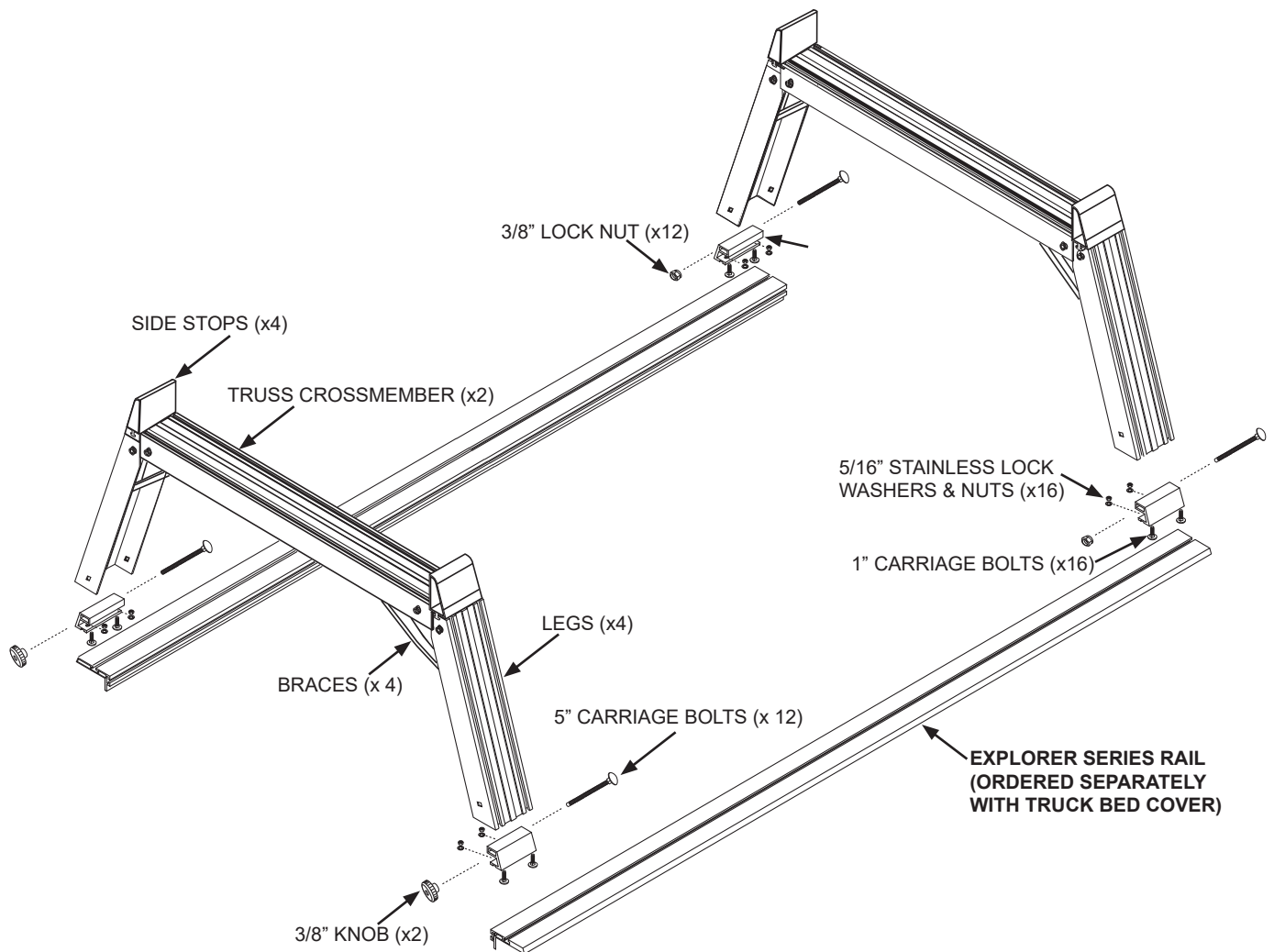

UTILITY RIG CROSSMEMBER BOX CONTENTS:

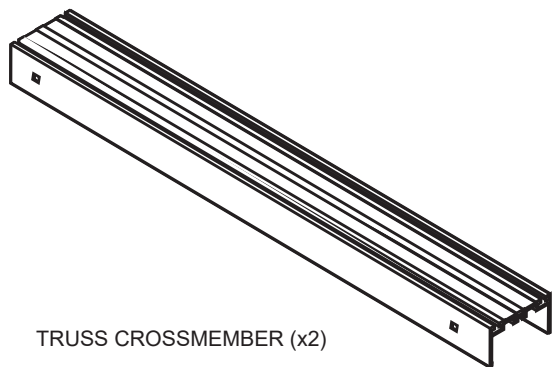

TRUSS CROSSMEMBER (x2)

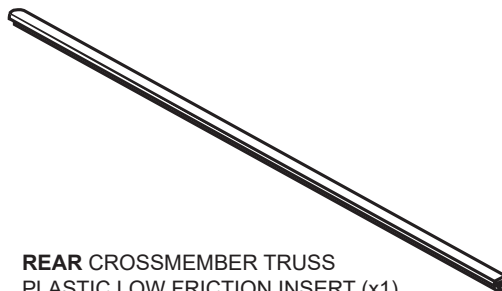

REAR CROSSMEMBER TRUSS
PLASTIC LOW FRICTION INSERT (x1)

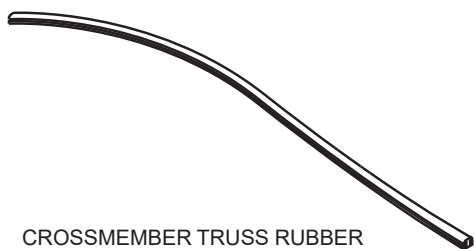

CROSSMEMBER TRUSS RUBBER
ANTI-WEAR INSERTS (x2)

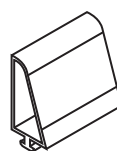

SIDE STOPS (x4)



3/8" KNOB (x2)

UTILITY RIG LEG BOX CONTENTS:



GUSSETS (x 4)

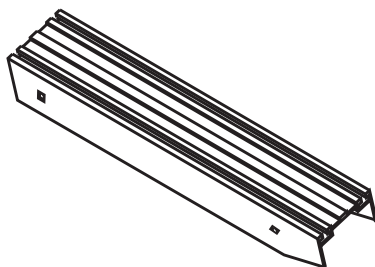

LEGS (x4)

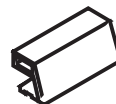

TRUSS MOUNTS (x4)



BRACES (x 4)

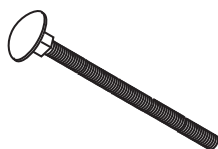

5" CARRIAGE BOLTS (x 12)



3/8" LOCK NUT (x12)



1" CARRIAGE
BOLTS (x16)



5/16" STAINLESS
LOCK WASHERS
(x16)



5/16" STAINLESS
LOCK NUTS (x16)

**INSTALL
TIP!**

A General Note on Assembly:

These parts have been precision cut to tolerances as close as one thousandth of an inch. Some fits are designed to be press fits, others are designed to be sliding fits; but nowhere should the use of great force be required for assembly. As with any piece of machined equipment, if a part is not fitting as it should, don't use excessive force, identify the problem and correct it. An initial misalignment of two parts can cause a burr on one of them and make smooth assembly difficult.

**INSTALL
TIP!**

STEP 1: INSTALL SIDE STOPS

HARDWARE USED:

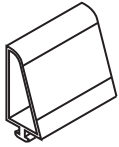

SIDE STOPS x 4



GUSSET x 4

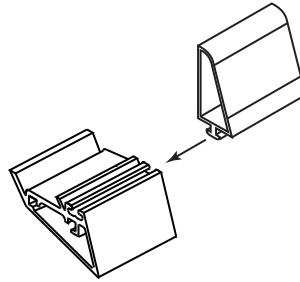

NOTE: To prevent Side Stops from the possibility of rattling, inject some silicone sealant into the T-slot of the gusset before inserting Side Stop.

STEP 2: ASSEMBLE LEGS & GUSSETS

HARDWARE USED:

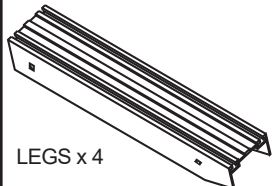

LEGS x 4



5" CARRIAGE BOLTS x 4



3/8" LOCK NUTS x 4

Install gussets into legs as shown until holes align, then slide the 5" carriage bolts through the holes. Install the 3/8" lock nuts on the 5" carriage bolts and tighten with a 9/16" wrench until they bear lightly (do not tighten yet) on the aluminum surface.

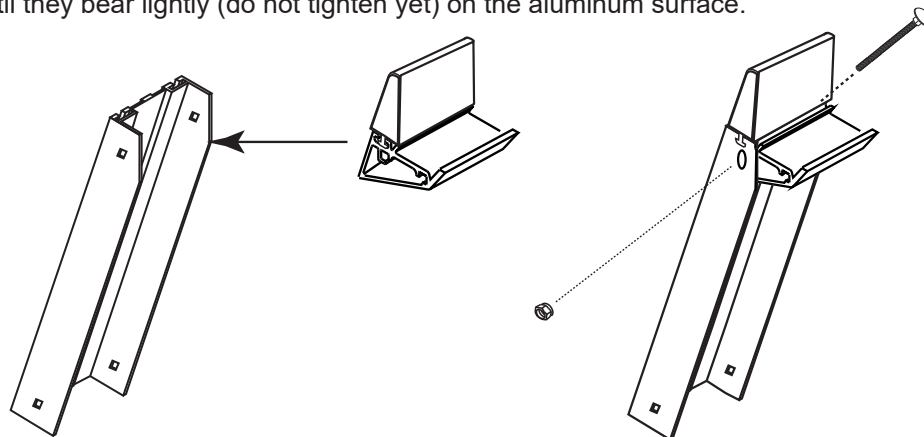

STEP 3: ASSEMBLE CROSSMEMBERS

HARDWARE USED:

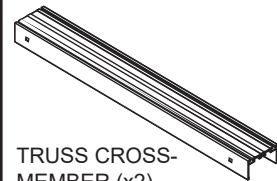

TRUSS CROSS-MEMBER (x2)



CROSSMEMBER TRUSS RUBBER ANTI-WEAR INSERTS (x2)



REAR CROSSMEMBER TRUSS PLASTIC LOW FRICTION INSERT (x1)



1" CARRIAGE BOLTS x 4

Slide a rubber anti-wear insert into the forward T-slot of each crossmember and slide a plastic low-friction insert into the **REAR** T-slot on the **REAR** crossmember. Slide 2 small carriage bolts (to be used for braces) into the T-slot on the underside of each crossmember.

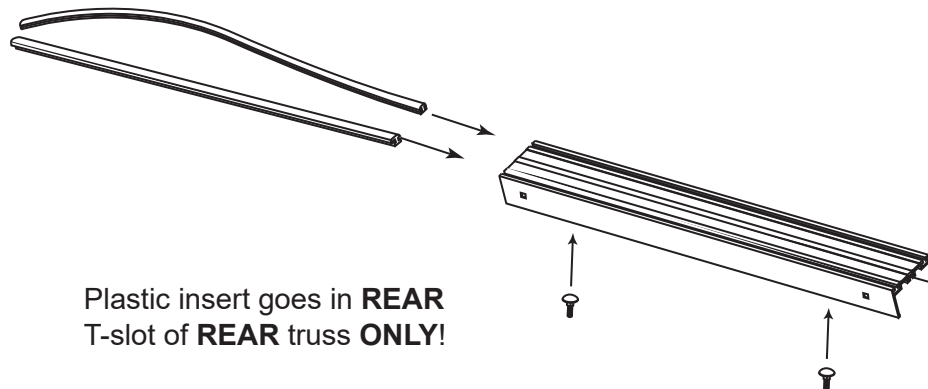

Plastic insert goes in **REAR** T-slot of **REAR** truss **ONLY!**

STEP 4: ASSEMBLE CROSSMEMBERS, LEGS & BRACES

HARDWARE USED:



5" CARRIAGE BOLTS (x 4)



3/8" LOCK NUT (x 4)



BRACES (x 4)



1" CARRIAGE BOLTS (x 4)



5/16" STAINLESS LOCK WASHERS & NUTS (x 8)

Install crossmember on gusset as shown, and fasten loosely with 5" long carriage bolts and 3/8" locknuts. Slide a small carriage bolt into the inside T-slot of the leg and install the brace between the leg and the crossmember using nuts and lock washers.

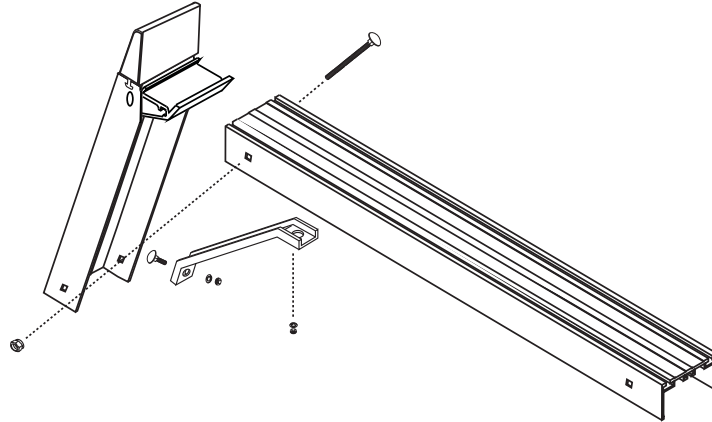

STEP 5: INSTALL TRUSS MOUNTS ON EXPLORER SERIES RAILS

HARDWARE USED:



1" CARRIAGE BOLTS (x 8)



5/16" STAINLESS LOCK WASHERS & NUTS (x 8)

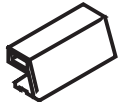

TRUSS MOUNTS (x4)

Slide two 1" carriage bolts into the upper T-slots on each end of both Rails. Place a truss mount on each of the bolt pairs (truss mount should be leaning inward as shown), positioning the mounts 1/8" in from the ends of the rails. Install lock washers and nuts and tighten with a 1/2" open end wrench.

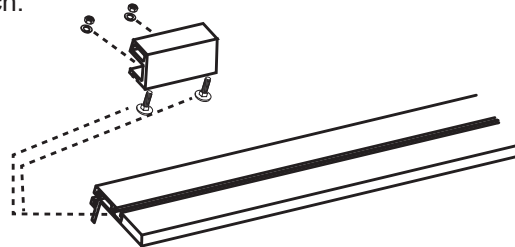

STEP 6: INSTALL PICKUP TRUSSES ON TRUSS MOUNTS

HARDWARE USED:



5" CARRIAGE BOLTS (x 4)



3/8" LOCK NUT (x 2)



3/8" KNOB (x2)

Lower the truss onto the truss mounts and slide the 5" long carriage bolts through the leg and mount. Install nuts and tighten with a 9/16" wrench until they bear LIGHTLY on the aluminum surface. Make sure that the truss is centered on the rails and that the visible joint between the leg and crossmember is as tight as possible, then tighten all 5" carriage bolts firmly. Note that the truss mount has an elongated hole for side-to-side adjustment of the truss legs. Tighten the nuts and knobs that secure the braces

