

# UltraGroove Electric™

Electric Retractable Tonneau Covers

## INSTALLATION INSTRUCTIONS

### DODGE RAM

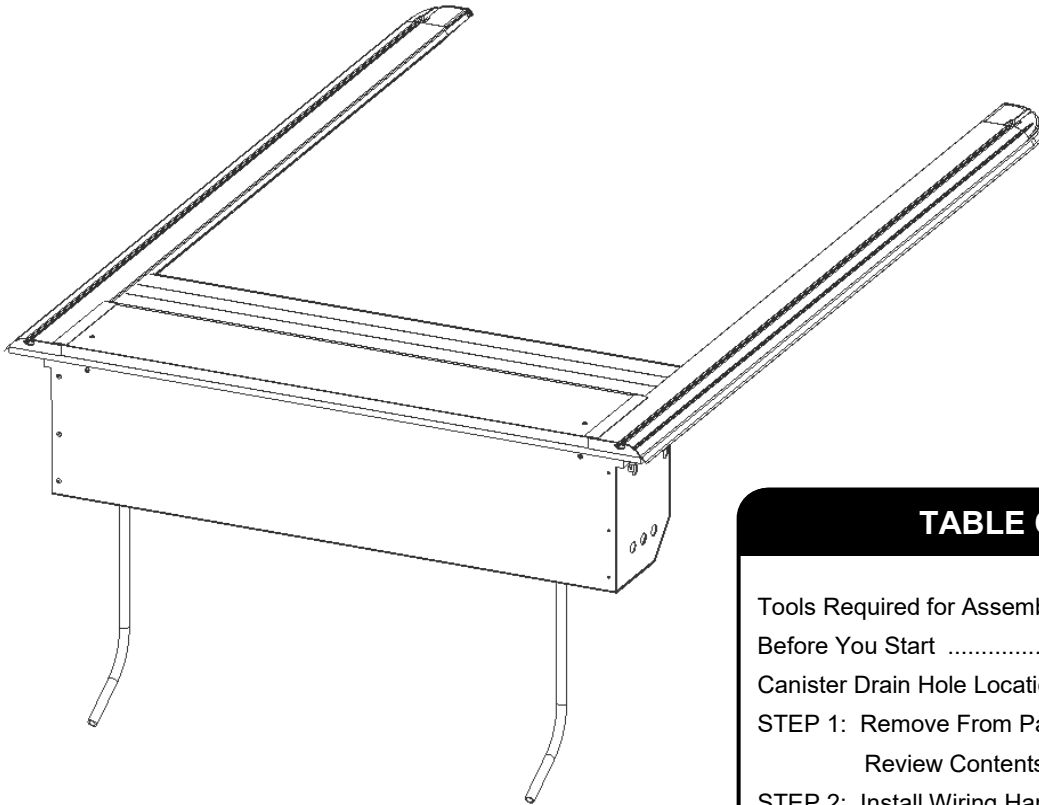

#### TABLE OF CONTENTS

Tools Required for Assembly .....	1
Before You Start .....	1
Canister Drain Hole Locations .....	1
STEP 1: Remove From Packaging, and Review Contents .....	1
STEP 2: Install Wiring Harness .....	2
STEP 3: Positioning Canister .....	2
STEP 4: Covering Rear Stake Pocket.....	3
STEP 5: Installing Rails .....	4
STEP 6: Installing The Top Cover.....	5
STEP 7: Installing The Clamp Extensions .....	6
STEP 8: Installing The Clamps .....	7
STEP 9: Installing Kickstands .....	8
STEP 10: Installing Tailgate DRAINTUBES .....	9
STEP 11: Lubricating and Placing the Sweep Seals.....	10
STEP 12: Connecting the Electronics .....	10
STEP 13: Installing Canister Drain Tubes.....	10
STEP 14: Release Handle Instructions.....	11
Maintenance .....	11
Release Handle Assembly Maintenance.....	11
Warranty Statement.....	12



## TOOLS REQUIRED FOR ASSEMBLY

Tape Measure

#2 Phillips Screwdriver

Note: There should be no drilling into the truck body needed on most standard or full-size trucks.

Side Cut or Needle Nose Pliers

Utility Knife

Masking tape

3/8" Wrench

5/32 Allen Wrench

## BEFORE YOU START!

Read the instructions carefully before you start.

## CANISTER DRAIN HOLE LOCATIONS:

This tonneau cover is designed to carry rainwater from the cover into the canister and then out through the drains. Most truck models have standard OE drain holes or plastic/rubber access ports in the front of the truck bed. Check to make sure your truck has the OE drain holes so that drilling into the sheet metal is not required. If drilling is necessary, be sure to check the underside of the truck bed for the best location. The holes should be located near the side and as far forward as possible. Use a drill bit suitable for sheet metal (such as a taper drill or step drill). Drill drain tube clearance holes at 3/4" (19mm). This will need to be done before installing the cover. **(WARNING: Use caution not to drill into wires, hoses or the cab!)**

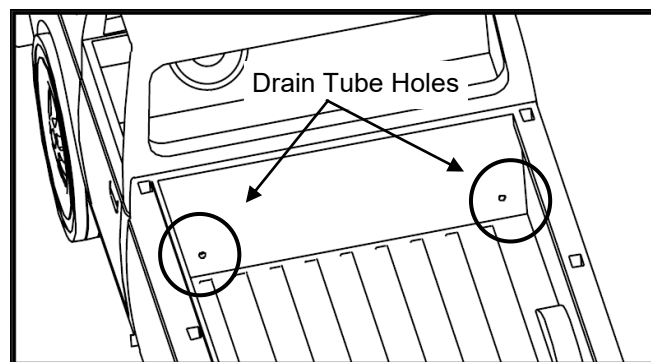

## STEP 1: REMOVE FROM PACKAGING AND REVIEW CONTENTS

A complete unit will consist of one canister box (marked box 1 of 2) and one rail box (marked box 2 of 2). Remove the Top Cover, Canister, Clamp pack, Hardware pack, Foam, Clamp Extensions and Drain Tubes from the Canister box. Remove the rails from the rail box (see caution below). Perform a quick inventory of the packaging contents to ensure all parts are there. Using the 3/8" wrench or socket, remove the 2 bolts holding the plywood packaging supports on the ends of the canister. Discard plywood packaging supports and bolts.

**CAUTION!**

TO AVOID SCRATCHING THE SURFACE OF THE RAILS, DO NOT SLIDE THEM OUT THE END OF THE BOX. OPEN THE BOX ALONG THE LENGTH, USE PLIERS TO PULL THE STAPLES, LIFT THE RAIL OUT. DO NOT USE A KNIFE TO CUT THE BOX

**CAUTION!**

## PACKAGING CONTENTS:

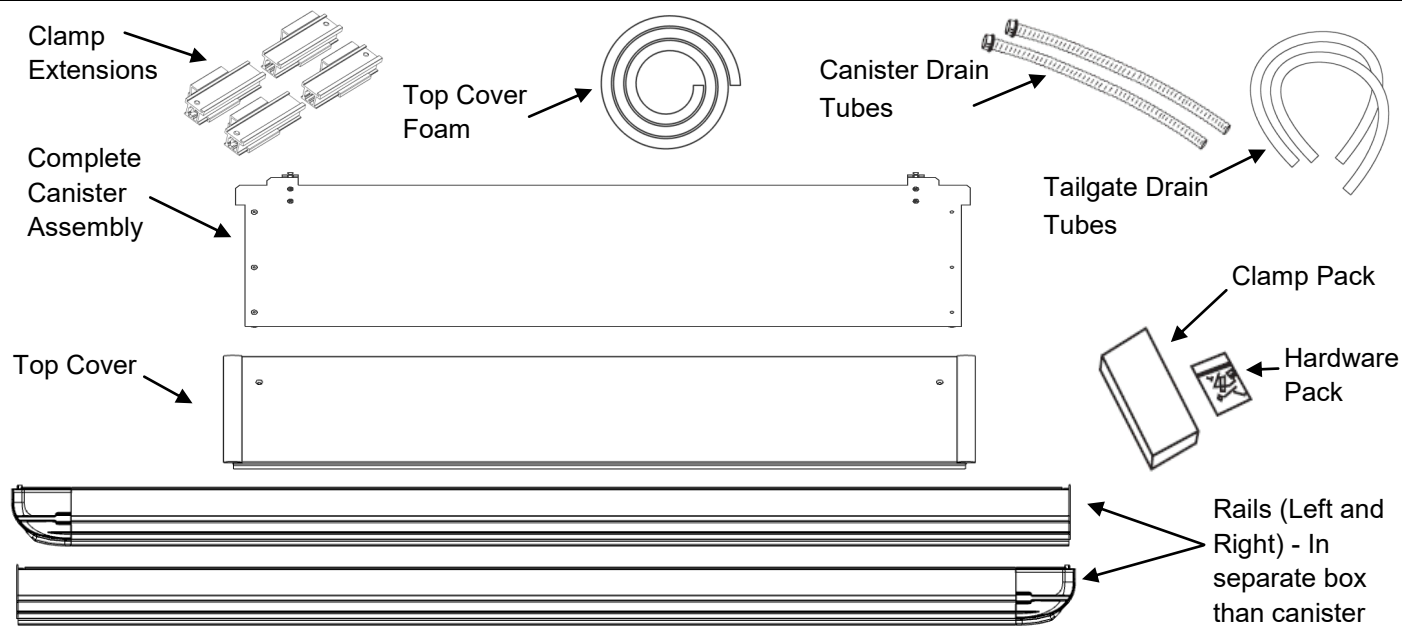

## STEP 2: INSTALL WIRING HARNESS

### HARDWARE USED:

(If the optional wire harness **Part# BL1120** is used, you may want to tape it to the main harness to ease having to pull them through the bottom of bed separately).

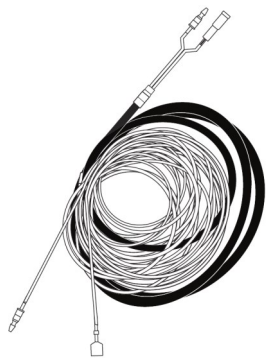

WIRE HARNESS x 1

From inside the truck bed push the long wire harness end without the plug through the stake pocket on the drivers side of the truck and out the underside of the truck bed box.

Leave approximately one foot of slack inside the box for mounting the electronics.

Route the wire harness under the truck and to the battery in the engine compartment.

Attach the fuse holder to the end of the Red/positive wire.

**(Do not attach to the battery yet.)**



ZIP TIES x 5

Secure the harness with wire ties provided after slack from the canister had been taken out.

## STEP 3: POSITIONING CANISTER

Place the Canister in truck bed just behind the cab and center it from side to side. You will need to place the canister on elevating objects, such as the box the canister came in or 5 gallon buckets. (If you have someone to help you, you can jump to step 5 and install the assembled canister and rails on the truck.)

**Note:** Ensuring that the canister is centered in the bed will help assemble the rails to canister in the next step.

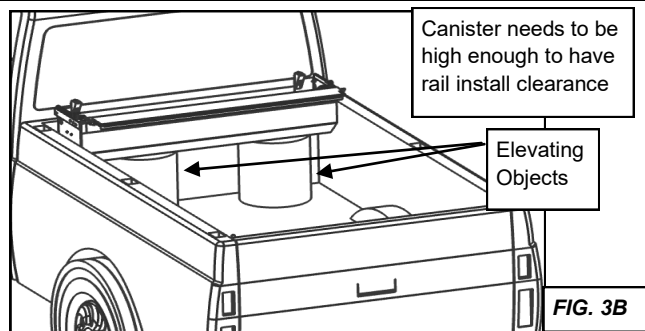

## STEP 4: COVERING REAR STAKE POCKET

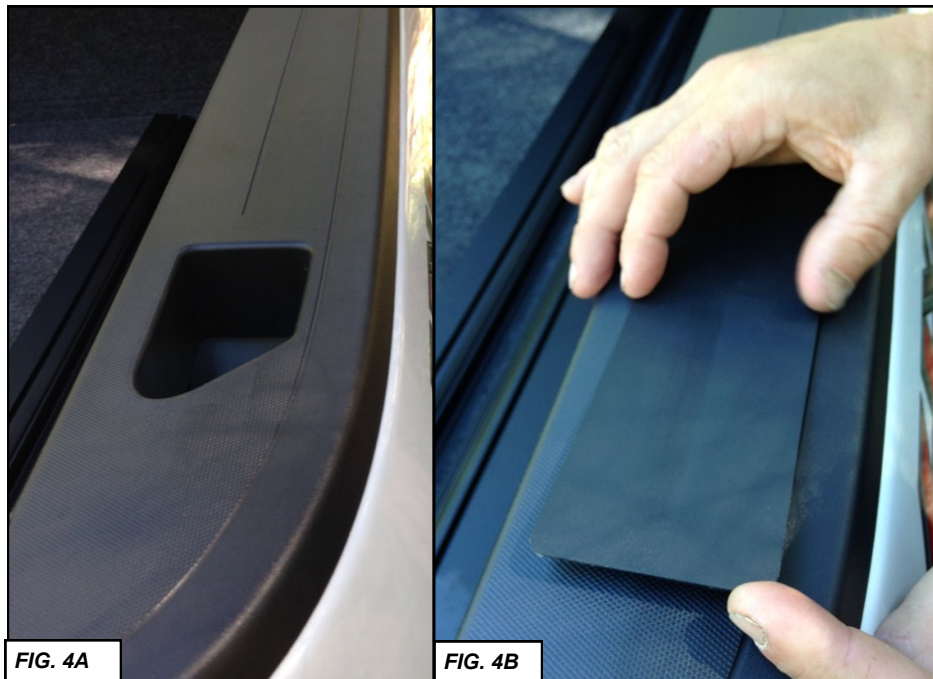
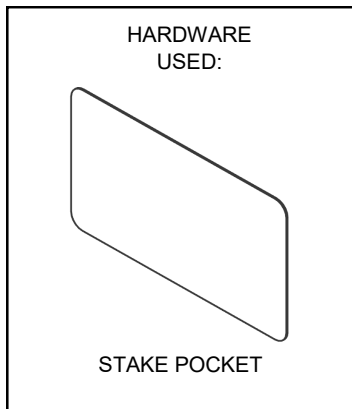

Included with your tonneau cover is a stake pocket cover. This helps to trim the outside seal for your rails (*FIG. 4C*). First clean the stake pocket hole area. If you have Isopropyl Alcohol this will work well. After the stake pocket area is dry peel off the adhesive backing and stick the cover on the hole so that it is entirely covered (*FIG 4A & 4B*).

# STEP 5: INSTALLING RAILS

Remove the protective paper from the foam on the underside of the Rail flanges. This is for packaging purposes only.

Next identify the left and right side rails (FIG 5A). The rail flange and foam towards the outside of the truck bed.

**HARDWARE USED:**



1/4-20 X 5/8" RAIL SCREW x 2



1/4" LOCK WASHER x 2



1/4" FLAT WASHER x 2

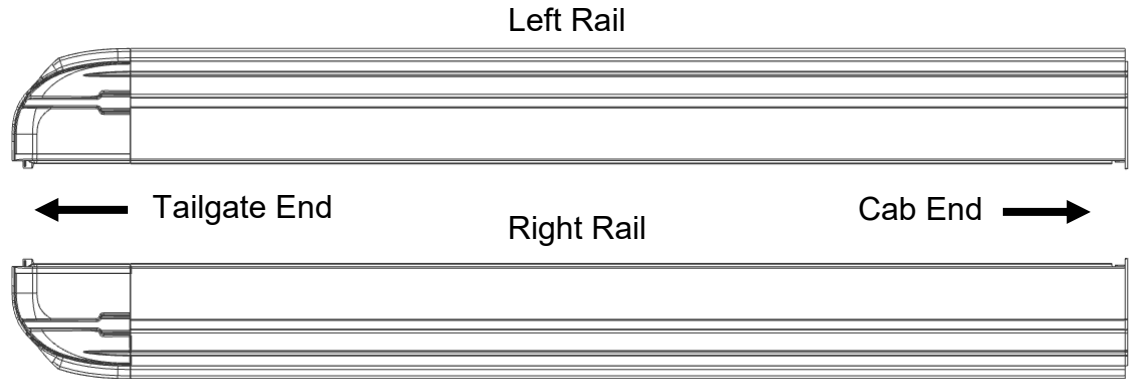

FIG. 5A

First make sure that the Lead Rib Flange is in pulled toward the tailgate enough to clear the Canister Flange and Canister Stop (FIG 5B).

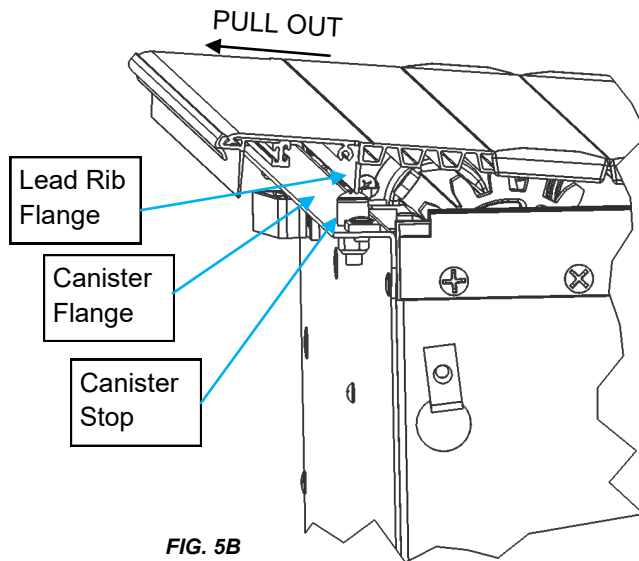

FIG. 5B

Figure 5B shows that the lead rib needs to be pulled out toward the tail gate. Now hook the rail into the rail guide and roll it down making sure to not get the sweep seal folded back into the rail (FIG 5C & 11A).

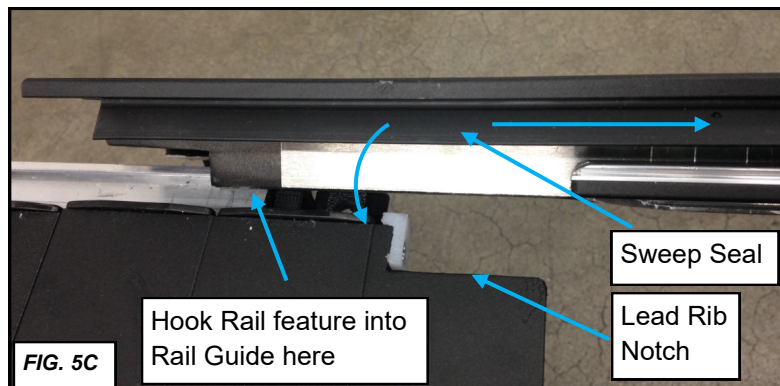
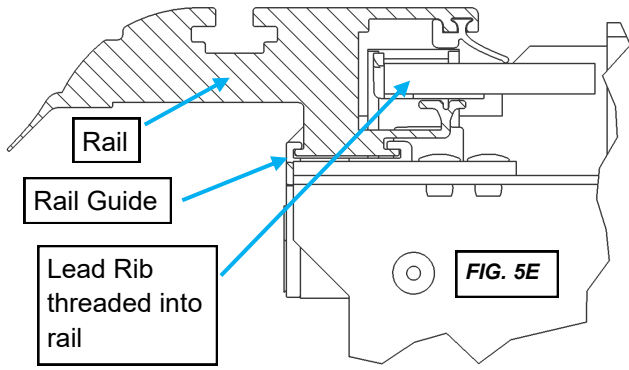
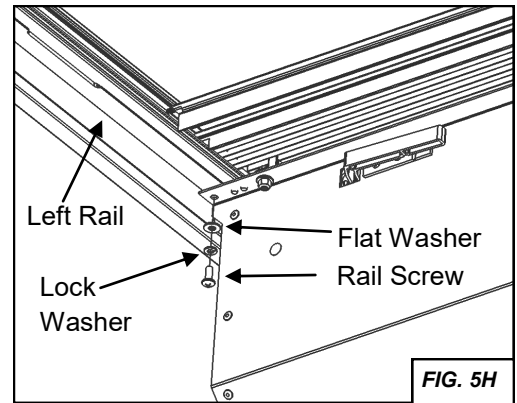
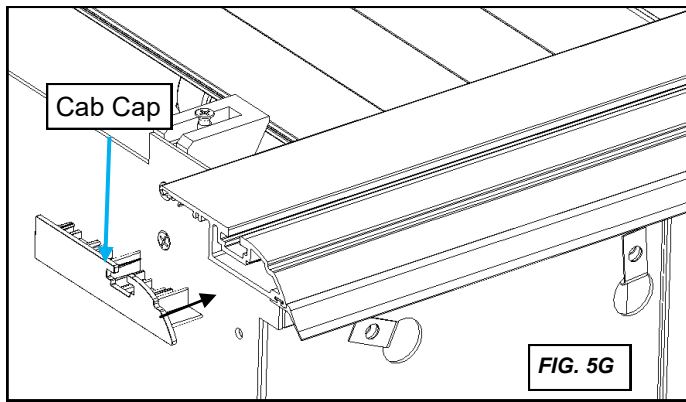

FIG. 5C



Then you can thread the Lead Rib into the rail and push the rail forward to the end of the can (FIG 5E & 5F). If you have difficulty threading the Lead Rib into the rail, you can gently lift up on the lead rib with your left hand while pushing the rail forward with your right. Next push the cab caps into the front of the rails (FIG 5G). Finally secure the rail to the canister with the Rail Screws provided with flat washer and lock washer (FIG 5H).



## STEP 6: INSTALLING THE TOP COVER

Remove the 303 protectant sponge that is adhered to the underside of the Topcover and set it aside for step 10. Shut the tailgate and pull the rails back until the tailgate cap seals have good engagement with your tailgate. A good way to check for proper engagement is to make sure the bottom cap and tailgate have 1/4" gap (FIG 6A).

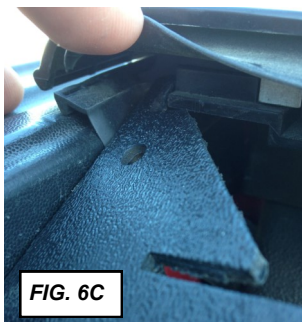
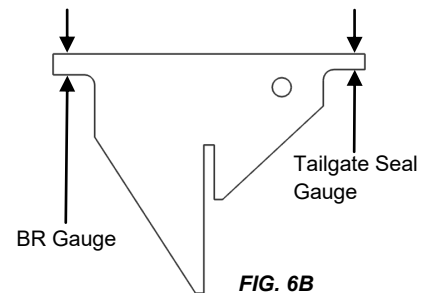
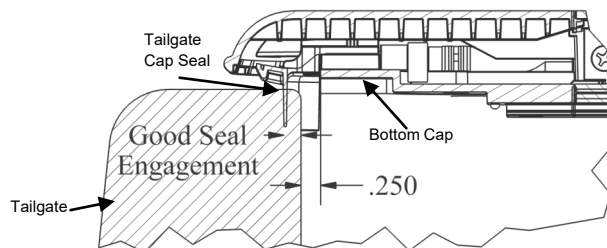
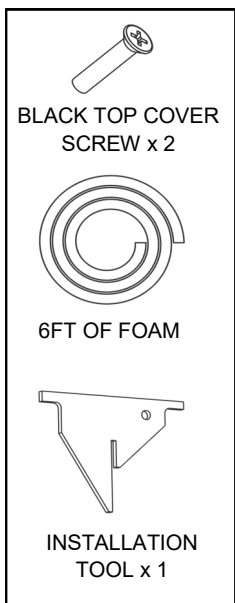

Another way to set the tailgate cap seals is to use the Tailgate Seal Gauge as shown in figure 6B & 6C. You should be able to just slide the Tailgate Seal Gauge in between the Tailgate Cap Seal and the Bottom Cap.

**WARNING: Proper Tailgate Cap Seal Engagement is important for getting the best possible water resistance out of your cover!**

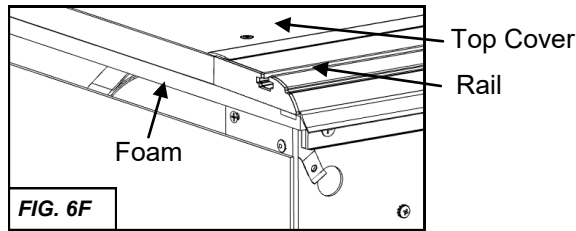
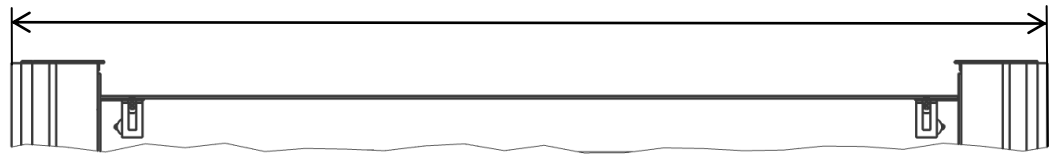
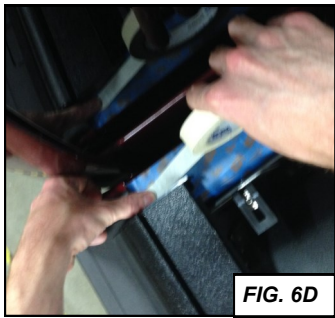

FIG. 6E

Next mark where the front of the rails sit and mark this position with masking tape, this will be a guide for placing your foam. (FIG 6D). Now pull the cover back until there is room to apply the foam. Lay the foam on the front sill of the truck from rail to rail, trimming the excess with a utility knife (FIG 6E).

Now scoot the rails and canister back on the foam and double check that your tailgate seal engagement is good. You can now install your top cover with the two included screws while making sure it aligns with the front of your rails (FIG 6F).

**WARNING: Proper top cover foam installation is important for getting the best possible water resistance out of your cover!** If there is a gap between the foam on the underside of the installed Top Cover and the front sill of the truck bed, use the extra roll of foam included in the kit to close the gap. Double up the foam on the front sill and trim the ends even with the inside of the rails.

## STEP 7: INSTALLING THE CLAMP EXTENSIONS

Slide the clamp extensions on the tailgate and cab end of each rail as pictured in Figure 7A-7E. Ensure that your tailgate end and cab end extensions are in the correct orientation and have the correct stick on shims. Each clamp extension is labeled for front left (FL), front right (FR), back left (BL), and back right (BR). The extensions go on the corners shown in figure 7A.

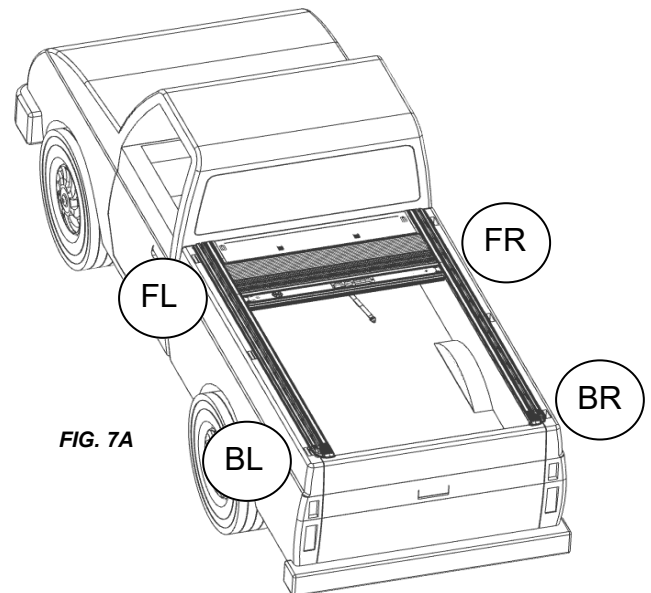

FIG. 7A

Next slide the extensions so they line up flush with the end of the clamp relief as shown in Figure 7F and tighten with a 5/32" Allen Wrench. If you have trouble sliding on the clamp extension, make sure your set screw is not sticking out the top of the clamp extension.

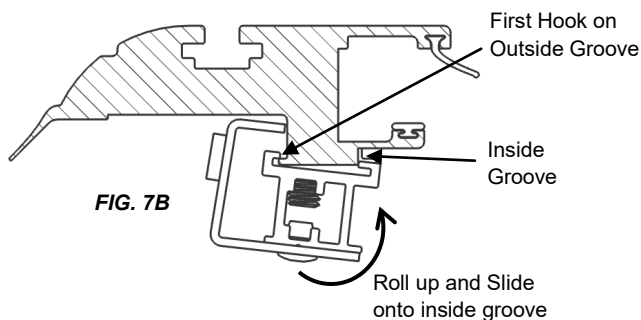

FIG. 7B

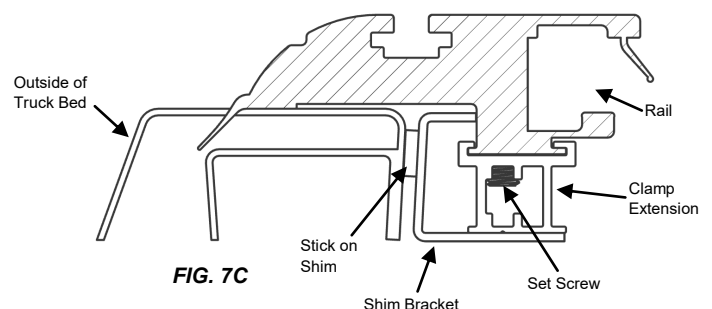
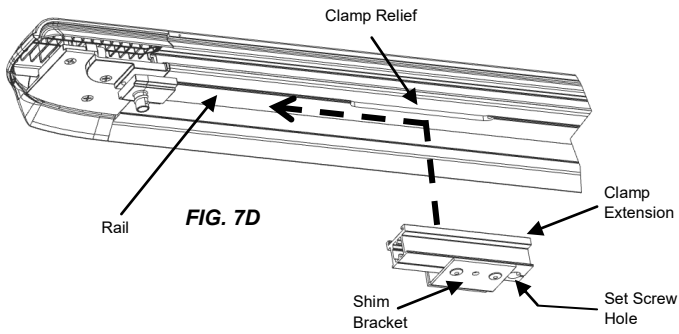
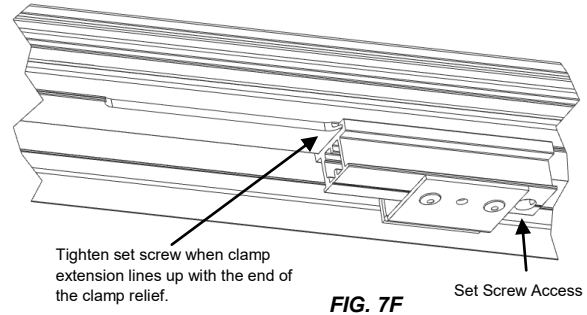
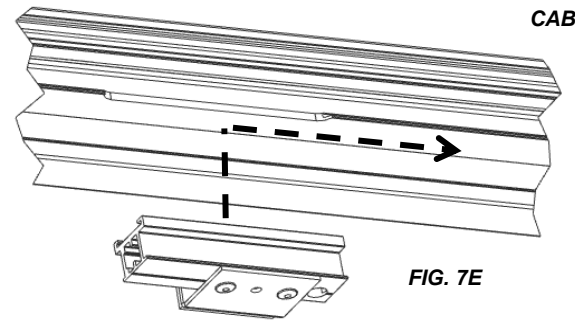

FIG. 7C

## TAILGATE END



## CAB END



## STEP 8: INSTALLING THE CLAMPS

Secure the rails to the truck bed by installing two clamp assemblies per rail. Slide the Clamp Grip onto the Clamp Extension toward the Shim Bracket and (FIG 8A and 8B). Then assemble the rest of the clamp parts as shown below (FIG 8D).

Now tighten your clamp turn knobs hand tight. Finally, check for proper spacing by measuring between the rails by attempting to insert the BR Gauge in between the rail metal and the handle stop (FIG 8E).

Firmly shut the tailgate with the cover in the closed position and check to make sure the "Tailgate Ajar" warning is not active. If the warning is active and more than reasonable force is necessary to fully shut the tailgate, more clearance may be necessary at the Rail End Caps.

You can also check the between the rail measurement at the canister and the tailgate end of the rails. The measurements should be equal to or less than those in Figure 8C. The Clamp Extensions have been pre-installed with brackets and shims to achieve the proper Between the Rail dimension (BR) when placed on an average factory truck bed. However, not all truck beds are average dimensionally and some have optional plastic caps or over the rail spray-in liners.

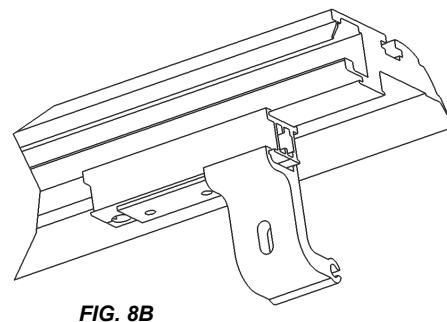
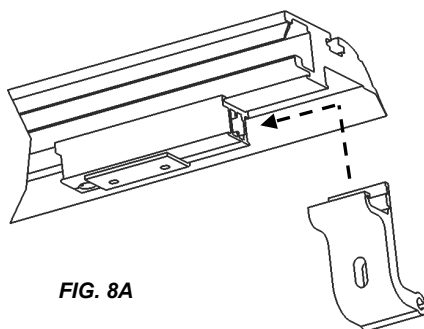



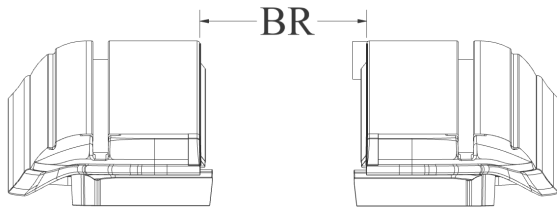

FIG. 8C

Part number is on the serial number label in the upper left corner of the canister (looking from tailgate).

PART NUMBER	BETWEEN RAILS (BR)
KE2124	58-3/16
KE2125	58-3/16

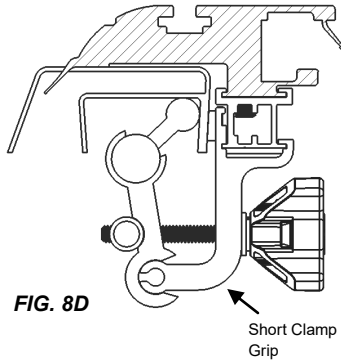

FIG. 8D

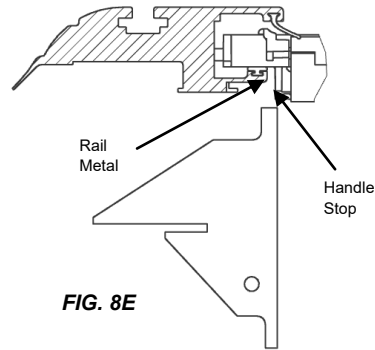

FIG. 8E

Another way to ensure proper fit is to check the side to side play of the handle assembly at the canister and at the tailgate end of the rails. There should be, at the minimum, enough play to allow the cover to move freely with no drag and at a maximum 1/8 inch per side. More than 1/8 inch per side may result in the cover opening unintentionally and in severe cases it may fall between the rail tracks and damage the cover. **There are “Stick on Shims” on the shim brackets that can be removed if the unit is too tight and “Stick on Shims” in the hardware pack that can be added if too loose. Refer to Figure 7C for “Stick on Shims” if adjustment is needed.**

Firmly shut the tailgate with the cover in the closed position and check to make sure the “Tailgate Ajar” warning is not active. If the warning is active and more than reasonable force is necessary to fully shut the tailgate, more clearance may be necessary at the Rail End Caps.

## STEP 9: INSTALLING KICKSTANDS

Install the kickstands at the tailgate ends of the rails. Loosely fasten the kickstand assembly to the clamp grip, on the side of the grip where the pivot foot will land on the flattest section of bed wall. Rotate the assembly so that it will push as squarely as possible on the bed wall, then tighten the wing nut. If the assembly is not positioned squarely against the bed wall, the assembly will rotate out of position, or the foot or knob can dislodge when the rail is flexed or loaded (FIG. 9C).

Run the adjusting bolt inward toward the bed wall, putting some pressure on the foot, then continue running the bolt inward using the knob until the rail is visually level. The adjusting bolt can be removed and the base flipped 180 degrees to adjust for varying clearance with the bed wall (FIG. 9B). Verify the BR dimension after the rails are leveled.

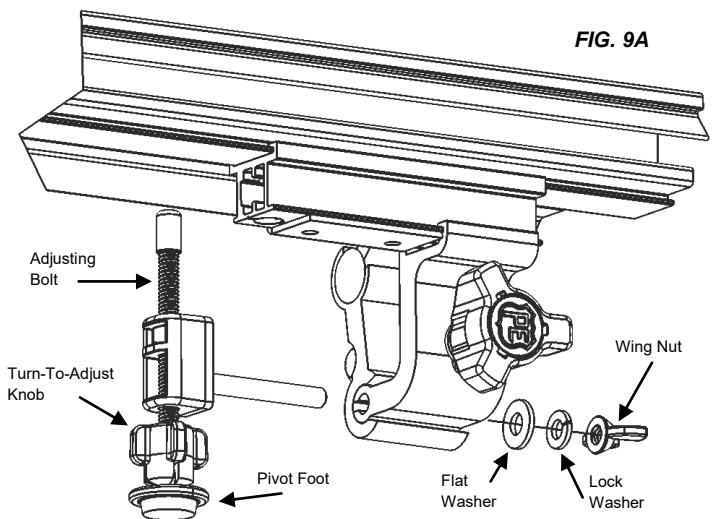

FIG. 9A

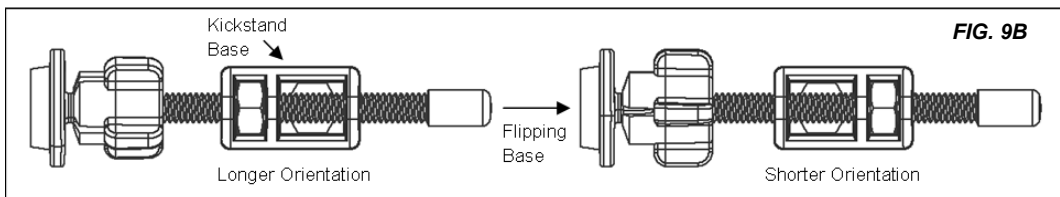

FIG. 9B

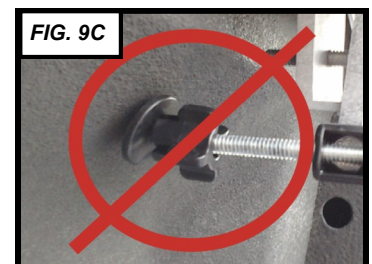

FIG. 9C

## STEP 10: INSTALLING TAILGATE DRAINTUBES

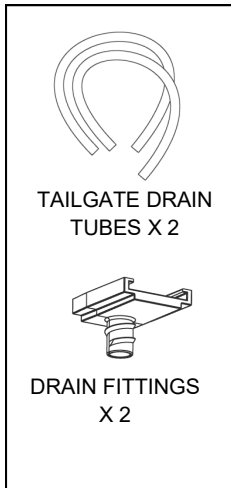
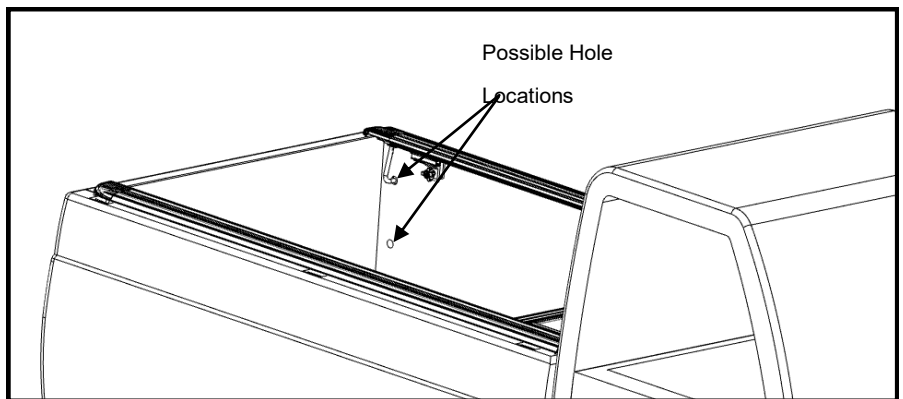
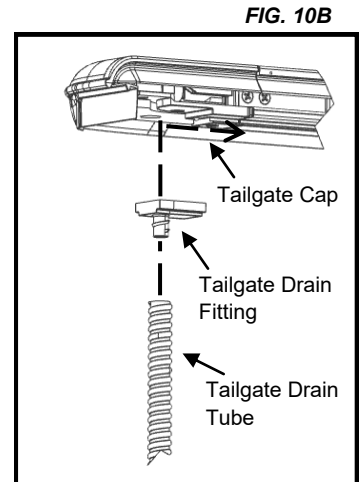

FIG. 10A

To install the tailgate drain tubes you need to find suitable holes in the rear stiffener of your truck bed. Figure 10C shows possible hole locations.

Next you will screw the drain tube into the drain fitting and slide it on the tailgate cap as shown in Figure 10B. There is an interference bump on the cap that will lock the drain fitting in place. Next you will need to thread the drain tube in the desired hole and trim the length of the tube if needed. If there are no holes on the tailgate side of your truck you will need to drill holes, make sure to check for wires you could damage first (5/8" or 16mm).



## STEP 11: LUBRICATING AND PLACING THE SWEEP SEALS

Locate the sweep seals (rubber weather strips) on the rails. Open the provided 303 brand protectant sponge pack that you removed from the Topcover in step 5 (find it adhered to the underside of the top cover). Wipe the underside of the sweep seal and the top of the wear strip.

Extend the cover to the tailgate. Use an Allen wrench if needed to carefully draw out the sweep seal (seal should be angled outwards toward the cover – not rolled in toward the bed rail). (Fig. 11A)

Proper care and placement of the sweep seal will ensure the smooth operation of the cover. Alcohol, petroleum based or silicon-based UV Protectants such as Armor-All® should be avoided and ARE NOT recommended for our covers.

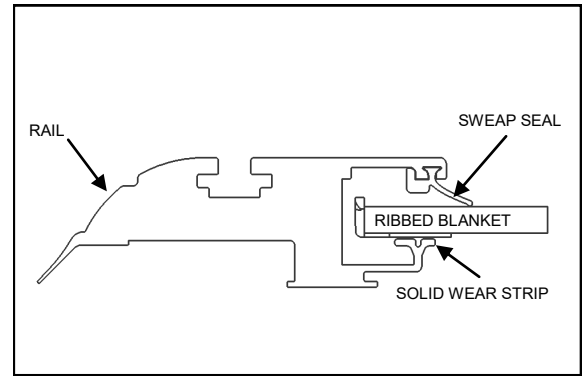

FIG. 11A

## STEP 12: CONNECTING THE ELECTRONICS

### HARDWARE

#### USED:



2-BUTTON REMOTE

KEY FOB x 2

The electronics box has been pre-mounted to the inside of the canister.

Connect the battery wire harness into the 2-wire plug at the end of the canister (**also connect the optional manual switch harness, if installed at this time**)

Attach the Red (positive) and Black (negative) wires to the battery or the truck manufacturers suggested connection points at this time.

Unit is now ready to operate.

Press the Open button to open cover and press the Close button to shut the cover.

## STEP 13: INSTALLING CANISTER DRAIN TUBES

First, ensure that the Foam Washer is in place on the Drain Fitting as this washer will help prevent water leakage. Next, test fit the drain tube to determine the length you want to trim it. Always caution on the long side. Trim the end that will be inserted through the truck bed using the wire cutters or a utility knife.

With the cover *opened*, insert the drain tube fittings into the pre-drilled holes on the underside of the canister by pushing them in place from under the canister. Drain Fitting should click into place.

Place the other end of the drain tube through the plastic/rubber access port or through the pre-drilled holes in the floor or the front wall of the truck bed. If routing through the front wall, ensure that the drain tubes are inserted and directed down so water flows out of the truck. (**WARNING: Use caution not to drill into wires, hoses or the cab!**)

To remove the drain tubes reach under the canister, grab the drain tube fitting and turn it while applying light downward pressure. When the retaining tabs align with notches in the bottom of the canister the Drain Tube and Fitting will drop out.

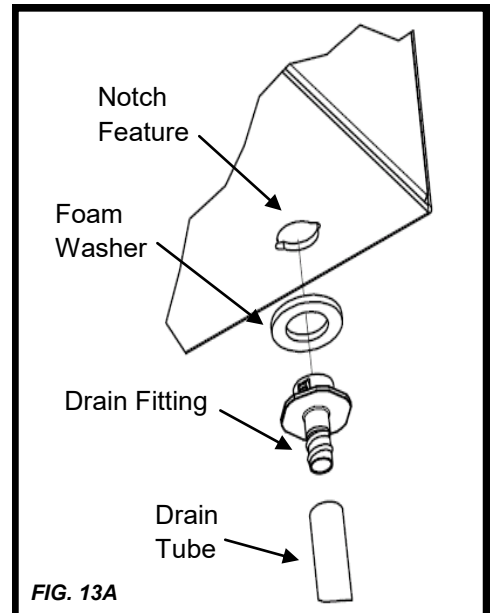

FIG. 13A

## STEP 14: RELEASE HANDLE INSTRUCTIONS

If power is lost to the Ultragroove Electric unit or the electric drive system fails to operate and you have to use the cover right away you can do the following to open or close the cover:

1. You will need to gain access to the release handle located on the driver side of the canister at the front of the truck bed. Once you have access to it, Pull the handle out away from the canister and pull out the handle kickstand behind it.
2. Settle the kickstand into the notch on the handle to hold the handle in place.
3. Now you should be able to push or pull the paneled blanket manually open or closed.

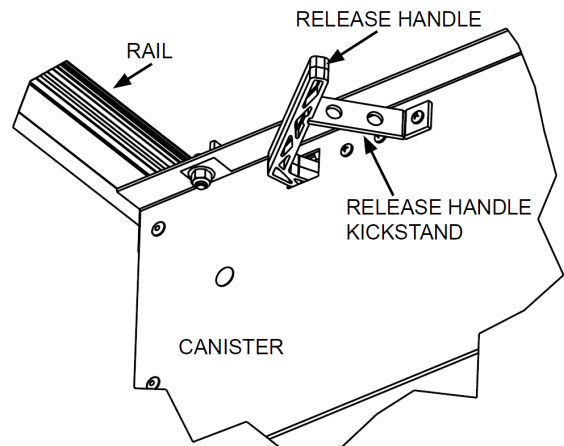

FIG. 14A

NOTE: The blanket will not lock unless you disengage the

kickstand and lower the release handle. With the handle released the cover will move a short distance and the cover will then lock itself in place. (Cover may not lock tightly against tailgate) This process will allow you to use the cover until power is restored. It is not meant for extended or permanent use.

## MAINTENANCE

After installation, if the cover is tight or hard to open and close, the shimming may need to be re-adjusted.

Periodically remove the Top Cover and clean out the canister.

Drain tubes may become clogged overtime and should be removed and cleaned. To remove the drain tubes reach under the canister, grab the drain tube fitting and turn it while applying light downward pressure. When the retaining tabs align with notches in the bottom of the canister the Drain Tube and Fitting will drop out. (FIG. 15A)

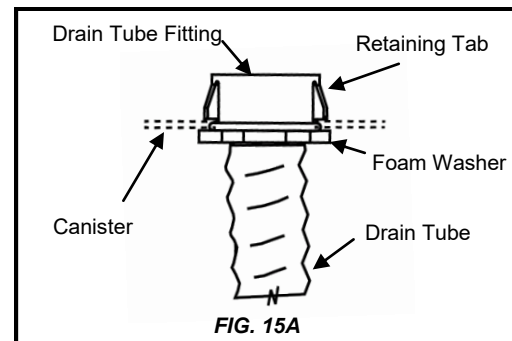

FIG. 15A

To help keep your Ultragroove Electric Retractable Tonneau Cover looking it's best, we recommend washing it the same way you wash your truck. However you should not wax your cover.

## RELEASE HANDLE ASSEMBLY MAINTENANCE

Maintenance of the Release Handle Assembly requires lubrication of the coupler located inside the canister. This is done during factory assembly but may need to be done from time to time during the life of your cover.

A small lubrication hole is provided on the coupler that a fine tipped grease gun can inject a small amount of grease into. A high quality waterproof wheel bearing grease is recommended.

To get to the coupler you will need to remove the rail clamps and end caps at the end of the rails. Use the manual release handle and **manually** pull the blanket out the end of the rails until you have access to the coupler inside the canister. Grease the coupler, cycle and spin it to distribute lubricant then reverse the process to re-assemble the cover being sure to **manually** push the cover back into place in the canister. **(DO NOT USE THE MOTOR TO RUN THE BLANKET INTO THE CANISTER OR YOU WILL DAMAGE THE RIB CAPS ON THE EDGES OF THE BLANKET.)**