

# Tune Up Kit

## INSTALLATION INSTRUCTIONS

**CUMMINS N-14/N-14 PLUS - FITS JACOBS MODELS**

**440/440A/445/450A/450B/455B/455C**

**ECONO KIT #P20920 and PREMIUM KIT #P20923**

### REMOVAL OF THE HOUSINGS FROM THE ENGINE

- A) Clean the top of the engine around all three engine brake housings, and remove valve covers.
- B) Mark the position of each housing on the engine, it is good practice to reinstall the housings in their original location.
- C) Loosen the slave piston adjusting screw lock-nuts.
- D) Remove the wiring connector to each of the three housings
- E) Loosen and remove the mounting capscrews, then remove the housings and gaskets, discard gaskets.

NOTE: Gaskets are supplied in Premium kit only. For Econo kit source 3-Pacbrake PN P16846 or 3-Cummins PN 387148L.

### DISASSEMBLY OF THE BRAKE HOUSINGS

- A) Place the housings (in order) on a clean work bench. NOTE: When removing all parts keep them in order of their original location for assembly.
- B) Remove the connector at the solenoid and at the lead out terminals. Remove the solenoid and discard the seals, harness, and lead out terminals.
- C) Remove the control valve covers. Use caution as the cover is under light spring pressure. Remove the springs, collars and control valves. Discard control valves, springs and retaining rings. NOTE: When using Premium Kit discard collars and control valve covers as new ones are supplied in these kits.
- D) Remove the slave piston adjusting screws and inspect the plungers, for spring pressure.
- E) Turn the housings over and remove the master piston flat springs and master pistons. Discard flat springs, capscrews and washers.

#### CAUTION: EYE PROTECTION MUST BE WORN WHEN PERFORMING THIS STEP!

- F) During slave piston removal, use extreme caution as the slave piston retainers are under heavy spring pressure. Use Cummins tool PN# 3871654 or a "c" clamp and a socket to compress the springs. Compress the retainer just enough to relieve the tension from the retaining ring, then remove the

retaining ring and back off the clamp. Remove the slave pistons and springs and check for signs of wear or foreign material. Do not discard any of these parts. Removal is for inspection and cleaning only. Inspect bores and pistons for damage. Pistons should slide out easily. Replace as necessary.

- G) Clean the housings and all saved parts in OSHA approved solvent and dry with compressed air, keeping saved parts in relation to their original positions.

### ASSEMBLY OF THE BRAKE HOUSINGS

- A) Assemble all parts into the housing using clean engine oil in the reverse procedure.
- B) When installing the slave piston assemblies and retaining rings, make sure the ring is seated in the groove and the open end of the ring is 90° from the slot in the housing.
- C) When installing the master piston assemblies, make sure the legs on the spring are centered on each side of the wear pad. NOTE: This kit contains two types of master piston return springs. The shorter version is for models 440A/440/445 and the longer version is for models 450A/450B/455B/455C.
- D) When installing the control valve assemblies, the collar **must be installed with the long side up**. Rotate the retaining ring 90° from the slot in the housing.
- E) Prior to solenoid installation, install the lower seal in the bore and the center and upper on the solenoid and lubricate with clean engine oil. Carefully insert into the bore, being sure that the seals do not get cut or twisted when tightening. Torque to 15 lbs. ft. (20 N•m)
- F) Install the slave piston adjusting screws loosely.
- G) Install the 3 gaskets supplied on the rocker box housings. Gaskets are supplied in Premium kit only. For Econo kit source 3-Pacbrake PN P16846 or 3-Cummins PN 387148L.
- H) Install on the engine as per manufacturers installation instructions, using the sequence on the reverse side.
- I) Torque housing in two steps; first to 35 lbs. ft., then to 70 lbs. ft.
- J) Slave adjustment is .023". Torque lock nut to 25 lbs. ft.

**PACBRAKE**<sup>®</sup>  
ENGINE BRAKES

**Part # P20920/P20923**

# Tune Up Kit

**Engine Application:  
Cummins  
N-14/N-14 Plus**

**Fits Models:  
Jacobs  
440/440A/445  
450A/450B  
455B/455C**

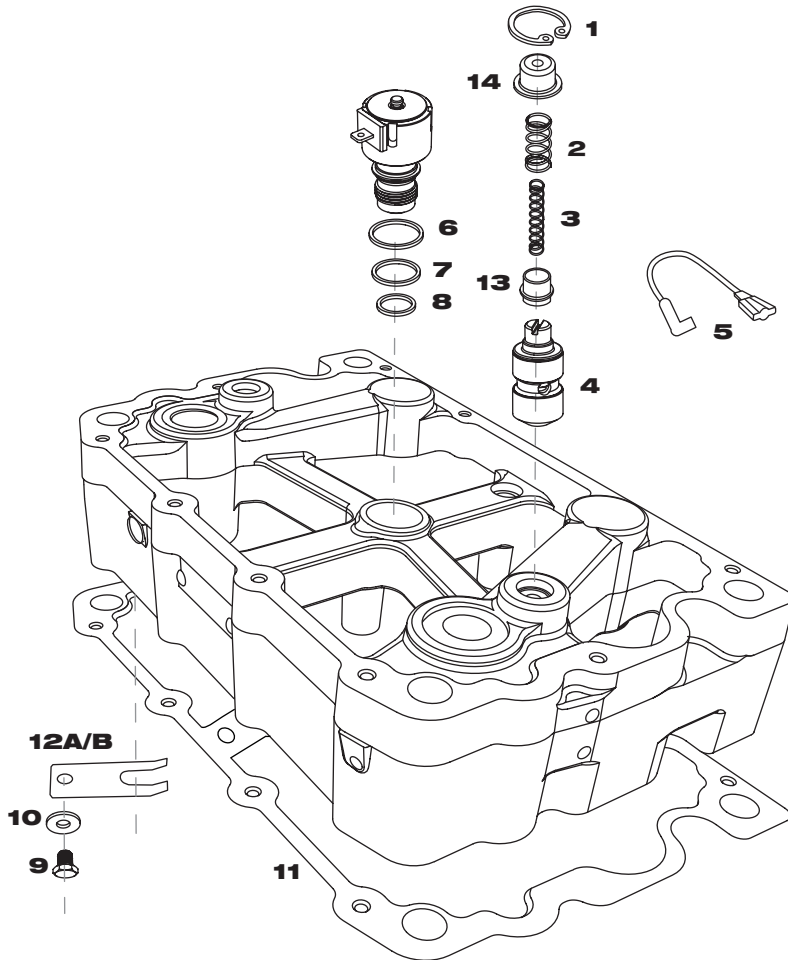

ILLUS. #	PART#	DESCRIPTION	Econo	Premium
			P20920	P20923
1	P11284	Snap ring-control valve	6	6
2	P11253	Outer control valve spring	6	6
3	P39100	Inner control valve spring	6	6
4	P11930	Control valve	6	6
5	P21296	Solenoid wire	3	3
6	P01081	Upper solenoid seal	3	3
7	P01082	Center solenoid seal	3	3
8	P01083	Lower solenoid seal	3	3
9	P01492	Capscrew	6	6
10	P01030	Spring retainer	6	6
11	P16846	Housing gasket	0	3
12A	P17412	Spring-master piston 440/440A/445	6	6
12B	P18792	Spring-master piston 450A/B/455B/C	6	6
13	P11251	C/V Spring collar	0	6
14	P26170	C/V Retainer cap	0	6

**Torque sequence**

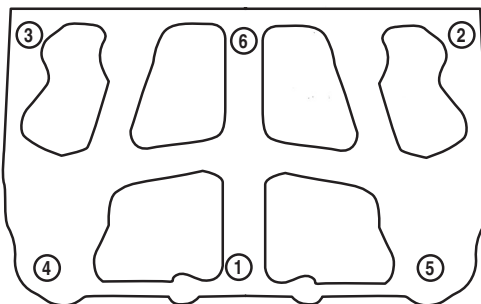

**PACBRAKE**  
ENGINE BRAKES



"A Sign of Quality"

Discover other performance engine parts on our website.