

Installation Manual

PACPRO[®]
PERFORMANCE PARTS by PACBRAKE



HP10291 KIT

*Dodge RAM 2500 4WD**

*Dodge RAM 3500 4WD**

1.75" Leveling Kit

*See PacPro Application Guide for proper fitment

KIT CONTENT



KIT CONTENTS

A	Coil Spring Spacer	2
B	Shock Extension	2
C	1/8"-18 X 3" Hex Head Cap Screw	2
D	1/8" Flat Washer	2
E	1/8" Lock Washer	2
F	1/8"-18 Nyloc Nut	2

Make sure all the items shown in the photo are provided in your kit before starting the installation.

Thank you and congratulations on the purchase of a Pacbrake leveling kit. Please read the entire manual prior to starting the installation to ensure you can complete it once started.

SAFETY WARNING

Altering the suspension system of your vehicle may cause it to handle differently than it did from the factory. Larger wheel and tire combinations may increase the leverage on the suspension, and steering components. This changes the way your vehicle handles and responds to abrupt maneuvers. Operate your vehicle at reduced speeds in all conditions to prevent loss of control. Failure to do so may result in serious injury. Pacbrake does not recommend the combined use of suspension lifts, body lifts, or other lifting methods.

INSTALLATION WARNING

Use caution when disassembling, and reassembling the vehicle. The proceeding instructions are guidelines only, the installer is responsible for ensuring that the vehicle is safe for use after performing the installation. Pacbrake recommends the use of an OE service manual for the model/year of the vehicle when disassembling and assembling factory related components.

Suspension components that use rubber or urethane bushings should be tightened with the vehicle at normal ride height. This will prevent premature wear or failure of the bushing. Prevent the suspension components from overextension by supporting them with a jack.

Due to the suspension geometry and vehicle tolerances, the amount of lift is a base figure. **Spacer thickness does not equate to the amount of lift due to the suspension geometry.** For example, a 1" thick spacer may provide a 2" lift. Always measure the vehicle ride height at all 4 corners before and after installation to ensure the results are as expected.

WHEEL ALIGNMENT AND HEADLIGHT ADJUSTMENT

It is necessary to have a proper and professional wheel alignment performed by a certified alignment technician to align the vehicle to factory specifications. After the installation is complete, check to ensure that the vehicles head lamps are aimed properly. If not, a head light alignment is required.

1 MEASURE THE STOCK RIDE HEIGHT

- Park the vehicle on a level surface.
- Using a measuring tape, measure the distance between the center of the wheel hub and the bottom of the fender well (this will give you your ride height).
- Note the ride height for all four corners.

2 REMOVE THE FRONT WHEELS

- Place wheel chocks in front of and behind both rear wheels.
- Raise the front of the truck high enough to remove both wheels and attain a comfortable working height.
- Place two jack stands under the vehicles frame.
- Lower the vehicle until the frame is supported by the jack stands.
- Use a floor jack to support underneath the front axle at a suitable lifting point such as the front differential.
- Remove the front wheels.

3 DISCONNECT THE SWAY BAR END LINKS

- Disconnect both the driver and passenger side sway bar end links.
- Tie the sway bar up and out of the way. Let the end link attached to the axle hang free.

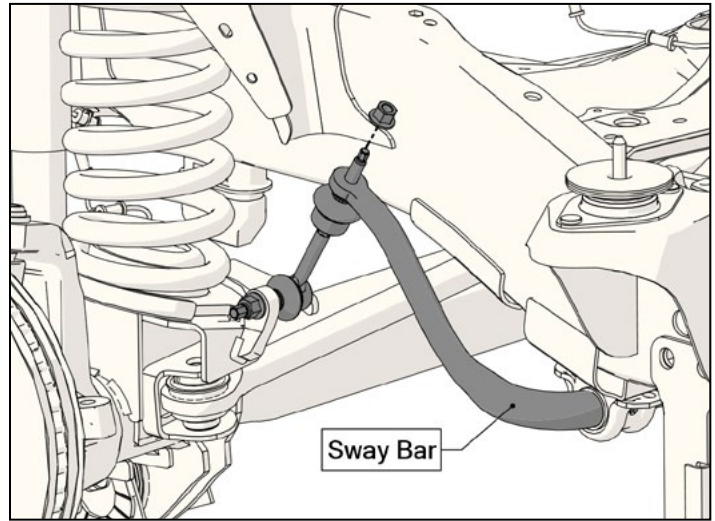

4 DISCONNECT THE TRACK BAR

- Disconnect the track bar from the track bar mount that is connected to the frame.

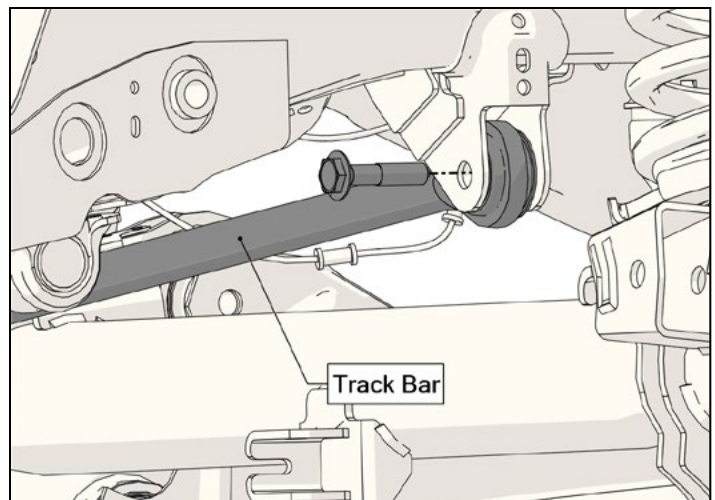

5 DISCONNECT THE FRONT LOWER SHOCK BOLTS

- Remove the OE hardware securing the shock to the lower shock mount as shown in Figure 5.
- Repeat this step for both the driver and passenger side.

NOTE: It may be necessary to raise or lower the floor jack under the axle slightly (this relieves the pressure being applied by the shock on the bolt) making the removal of the lower shock bolt easier.

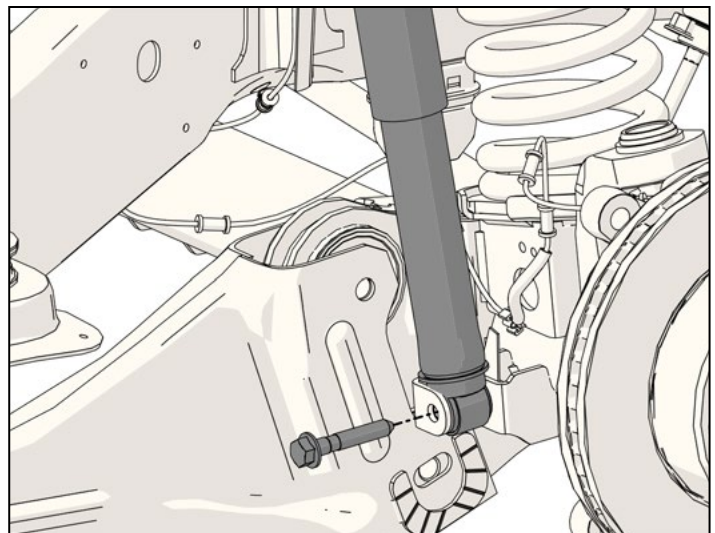

6 REMOVE THE COIL SPRING

- Lower the front axle until there is enough clearance to safely remove the coil spring, and the coil pad from the vehicle.
- Using a pair of side cutters, snip of the nipple that is on the coil pad. Refer to figure 6
- Repeat this step for both the driver and passenger side.

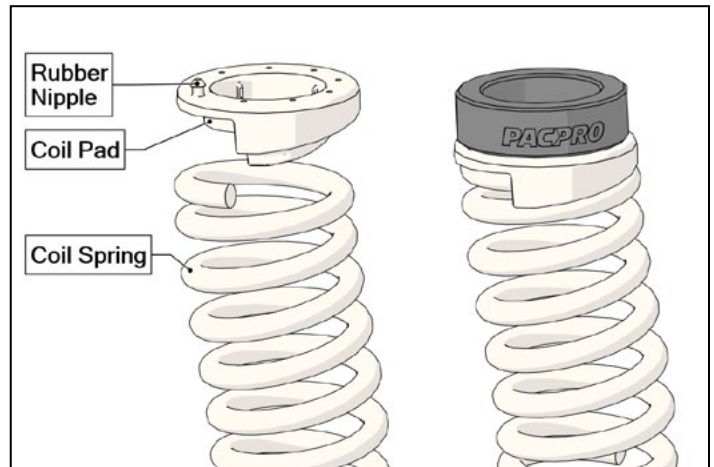

7 INSTALL THE COIL SPRING SPACER

- Install the coil spring spacer, coil pad and the coil spring into the truck.
- Repeat this step for both the driver and passenger side.

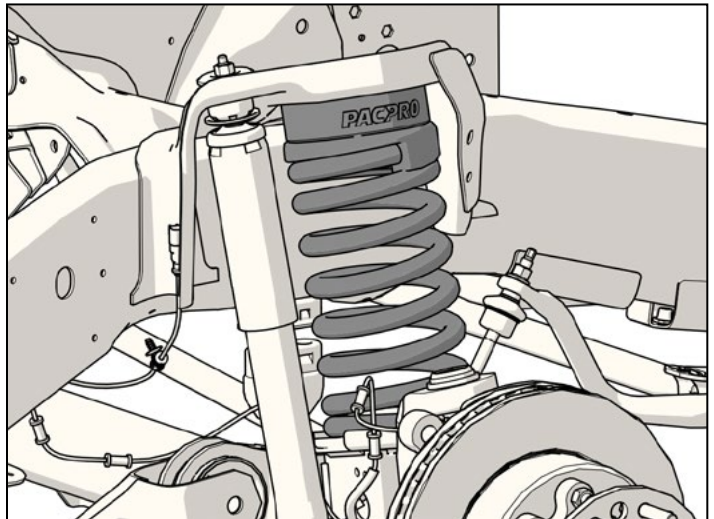

8 INSTALL THE SHOCK EXTENSIONS

- Using the factory OE hardware install the shock extension into the shock axle mount and torque it according to the manufacturers specifications Refer to figure 8
- Using the provided $\frac{9}{16}$ " hex head cap screw, washers and nyloc nut to connect the shock absorber to the shock extension. Torque the $\frac{9}{16}$ cap screw to the manufacturer's specifications
- Repeat this step for both the driver and passenger side.

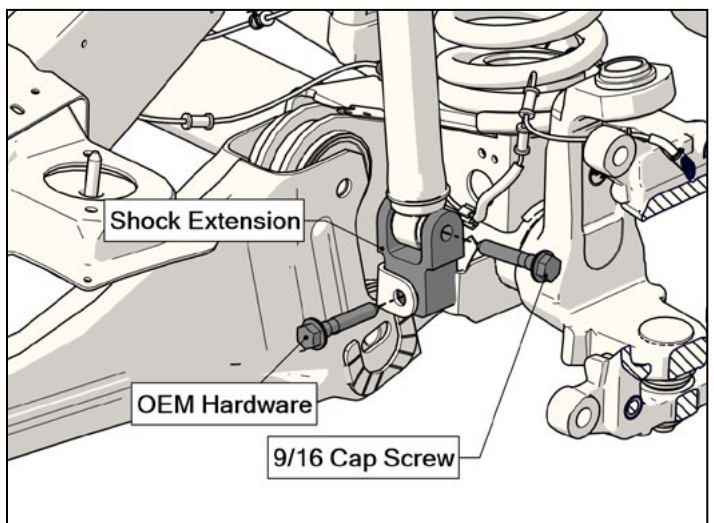

9 REINSTALL THE TRACK BAR

- Reconnect the track bar to the frame track mount using the OE hardware.
- Torque the hardware to the manufactures specifications

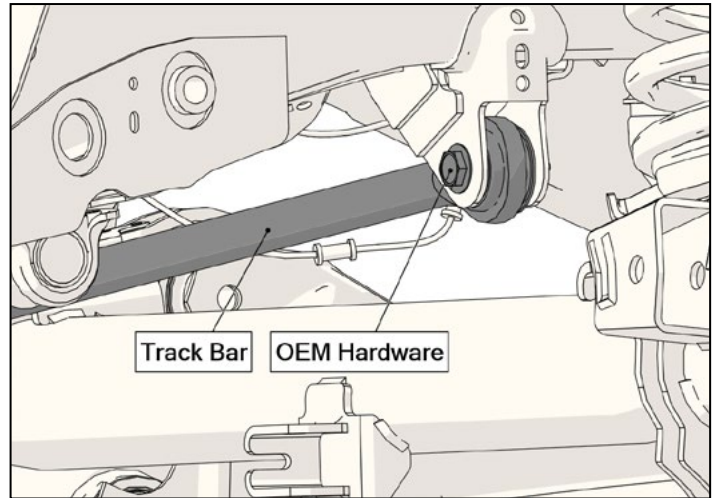

9

10 RECONNECT THE SWAY BAR END LINKS

- Use the OE hardware to reconnect the sway bar end links. Do not torque the end links to specification

NOTE: Suspension components that use rubber or urethane bushings should be tightened with the vehicle at normal ride height. This will prevent premature wear or failure of the bushing.

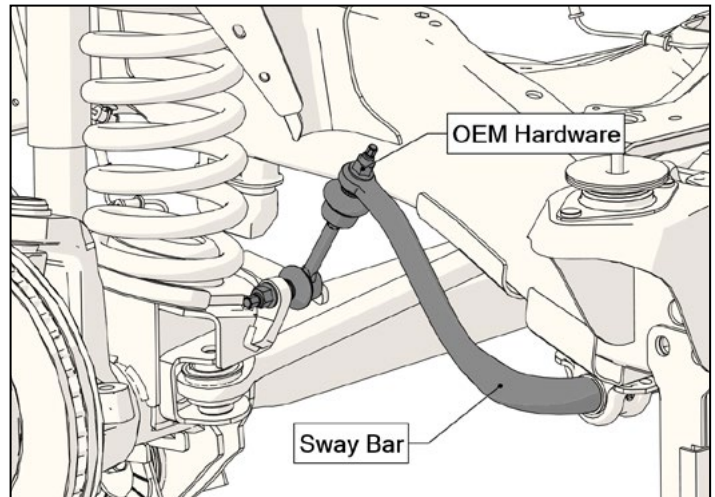

10

11 REINSTALL THE WHEELS

- Install the wheels and torque them to factory specification
- Raise the vehicle in order to remove the jack stands from under the frame and then lower the vehicle back to the ground.
- Torque the sway bar end links according to the manufacturer's specifications
- Use a measuring tape to measure the distance between the center of the wheel hub and the bottom of the fender well for all four corners. This is your new ride height. Ensure the results are as expected.

POST INSTALLATION WARNING

Once the installation is complete and the vehicle is lowered to the ground, check all parts which have rubber or urethane components to ensure proper torque. Move the vehicle backwards and forwards a short distance to allow suspension components to adjust. Turn the front wheels completely left then right and verify adequate tire, wheel, brake line, and ABS wire clearance. Test and inspect steering, brake and suspension components. Inspect brake/ABS lines for adequate slack at full extension. Failure to perform the post installation checks may result in vehicle damage.

VEHICLE HANDLING WARNING

Larger wheel and tire combinations may increase the leverage on the suspension, and steering components. Increasing the height of your vehicle increases the likelihood of rollover or loss of control during abrupt manoeuvres, especially at high speeds. Operate your vehicle at reduced speeds in all conditions to prevent loss of control. Failure to do so may result in serious injury.

WHEEL ALIGNMENT AND HEADLIGHT ADJUSTMENT

It is necessary to have a proper and professional wheel alignment performed by a certified alignment technician to align the vehicle to factory specifications. After the installation is complete, check to ensure that the vehicles head lamps are aimed properly. If not, a head light alignment is required as well.

VEHICLE RE-TORQUE AND SAFETY INSPECTION

Upon completion of all services and adjustments performed on your vehicle, and within 50 miles of driving, check to ensure all fasteners and hardware are properly torqued to specification as noted in the vehicles factory service manual