

# Installation Manual

**PACBRAKE®**



## 10216 KIT

Chevrolet Silverado / GMC Sierra 1500 (2WD / 4WD) †\*

† For short (69.3") & medium (78.7") truck bed lengths  
(Not for 97.6" Truck Beds)

**WILL NOT FIT VEHICLES EQUIPPED WITH MAGNERIDE.**

## KIT CONTENTS



Make sure all the items shown in the photo are provided in your kit before starting the installation.

## KIT CONTENTS

<b>A</b>	Air Spring	(2)	HP10000D
<b>B</b>	Upper Bracket Driver Side	(1)	HP1432
<b>C</b>	Upper Bracket Passenger Side	(1)	HP1431
<b>D</b>	Lower Bracket	(2)	HP1433
<b>E</b>	J Clamp	(4)	HP1434
<b>F</b>	<b>SUB GROUP</b>	<b>(1)</b>	<b>HP10217</b>
<b>F1</b>	Capscrew, Countersunk	(8)	HP1008
<b>F2</b>	Bolt 3/8 x 1 1/2 NC	(2)	C18018
<b>F3</b>	Flat Washer 3/8	(2)	C18006
<b>F4</b>	Flat washer 3/8 SAE	(14)	C653
<b>F6</b>	Screw Hex Cap 3/8-16	(4)	HP1416
<b>F7</b>	Nut Nyloc 3/8-16	(10)	HP1000
<b>F8</b>	U-Bolt	(2)	HP1331
<b>F9</b>	Airline Hose Assembly	(1)	HP1344
<b>F10</b>	Bolt, Self-Tapping 3	(2)	HP1078
<b>F11</b>	Cable Clamp 3/8	(2)	HP1435
<b>F12</b>	Cable Clamp 1"	(1)	HP1436
<b>F14</b>	Bolt Leader Tool	(1)	HP1440
<b>F15</b>	Heat Shield	(1)	HP0012
<b>F16</b>	Worm Gear Ring Clamp (2 1/2" - 4 1/2")	(2)	HP1001
<b>F17</b>	Worm Gear Ring Clamp (4 1/2" - 6 1/2")	(2)	HP1377
<b>H</b>	<b>AIR SPRING SUB GROUP</b>	<b>(1)</b>	<b>HP10180</b>
<b>H1</b>	Fitting, Brass, Push	(2)	HP1099
<b>H2</b>	Tywrap	(6)	C11618
<b>H3</b>	Roll Plate	(4)	HP10054

## REQUIRED TOOLS

- Hoist or Floor Jacks
- Safety Stands
- Safety Glasses
- Torque Wrench
- Standard Open-End Combo Wrenches
- Ratchet
- Metric and Standard Sockets
- 7/32" Allen Wrench (socket if available)
- 5/16" Drill Bit (very sharp)
- Heavy Duty Drill
- Hose Cutter, Razor Blade or Sharp Knife
- Air Compressor or Compressed Air Source
- Spray Bottle with Dish Soap & Water

**KIT CONTENTS**

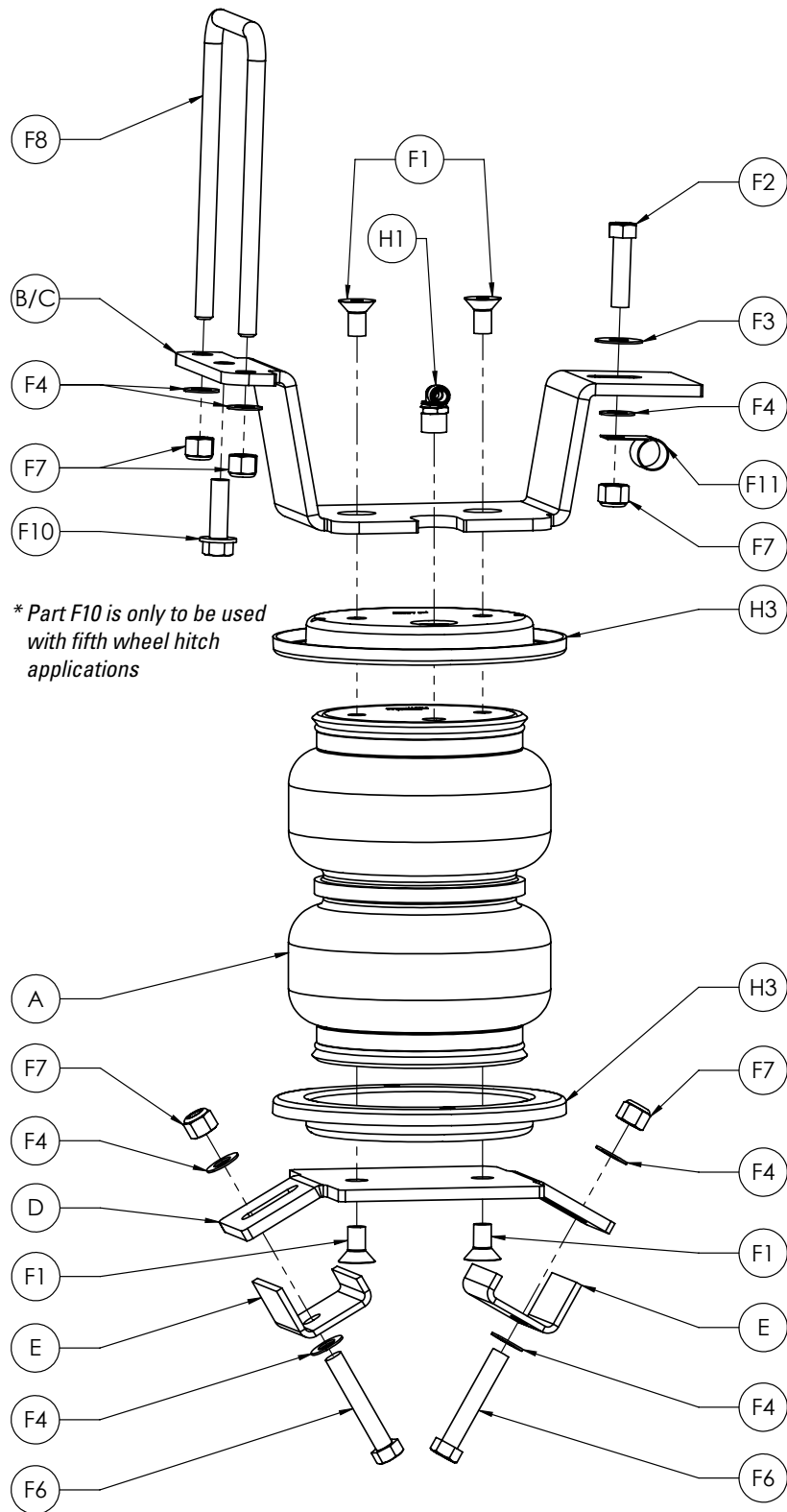

*\* Part F10 is only to be used with fifth wheel hitch applications*

←  
**FRONT OF VEHICLE**

**Note: Passenger's side assembly shown.**



**WARNING:** This product can expose you to the chemical Hexavalent Chromate, which is known to the State of California to cause cancer and birth defects or other reproductive harm.

Thank you and congratulations on the purchase of an air suspension kit. Please read the entire installation manual prior to starting the installation to ensure you can complete the installation once started.

### IMPORTANT:

This air suspension kit will not increase the GVWR (Gross Vehicle Weight Rating), as the GVWR is determined by the axle rating. Do not exceed the maximum capacity listed by the vehicle manufacturer.

### BEFORE YOU START:

**NOTE:** Some vehicles are equipped with a rear wheel brake proportioning valve. Check with the manufacturer before installing the air spring kit, as it may affect braking performance.

1. Ensure the application information is correct for the make, model and year of the vehicle you are installing the kit on.
2. It is recommended to use a good quality anti-seize on all fasteners. This will reduce the chance of corrosion on the fasteners and will help facilitate removal, if required at a later date.

## 1 RAISE THE REAR AXLE

- Remove any unnecessary weight from the vehicle to attain normal ride height. This is important for correct initial air spring setup and adjustment.
- Park the vehicle on a level surface.
- Record the vehicle's normal ride height, which is the distance between the center of the axle and the horizontal wheel well flange. Ensure both sides are the same before raising the vehicle.
- Raise the rear axle high enough to remove both rear wheels and attain a comfortable working height.
- Place two jack stands under the axle, as shown in figure (1A-1B)
- Lower the floor jack until the vehicle axle is supported by the jack stands.
- Ensure the normal ride height measurement recorded earlier is the same. Adjust if necessary before proceeding.
- Once the rear axle is raised correctly, remove the rear wheels.

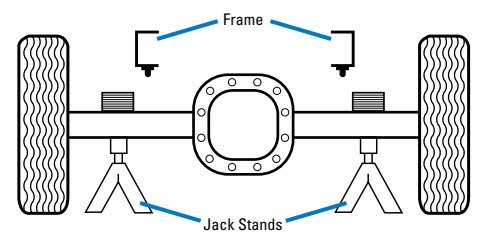

1A



1B

## 2 REMOVE THE LINE HOLDER

- Remove and discard the ABS line holder located on the left side (driver's side) of the frame rail, on the inside of the frame, just forward of the axle
- Pull the ABS line holders out from the frame and remove from the ABS line. They are attached to the bottom of the frame, behind the axle, on the left (driver's) and right (passenger's) hand side. (See picture 2C)
- Use a small screw driver to unhook the clamp from the line and remove it. Discard the clamp since it will no longer be used.
- Install the small cable clamps facing up, onto the ABS line where the stock line holders were attached with the hole facing forward on the line. Do this on both sides. (see picture 2D)
- Leave the ABS line hanging loose for later installation.

**CAUTION:** BECAUSE THE EMERGENCY BRAKE CABLE IS IN A LOCATION THAT MAKES IT POSSIBLE TO RUB A HOLE IN THE SIDE OF THE AIR SPRING, IT WILL BE NECESSARY TO RELOCATE IT AWAY FROM THE AREA WHERE THE AIR SPRING IS INSTALLED.

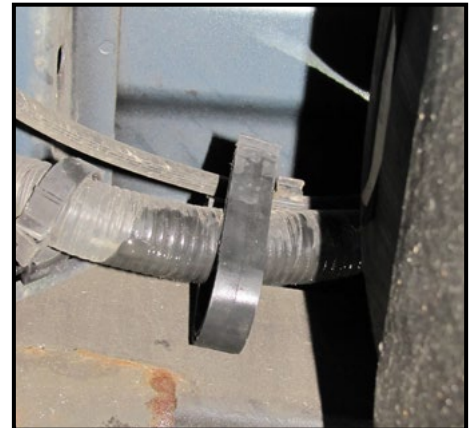

2A



2B



2C



2D

### 3 REMOVE THE JOUNCE BUMPERS

- Remove the jounce bumpers from under the frame rails on both sides. (See picture 3A)
- Remove the jounce bumpers by unbolting them from the jounce bumper mounting cups welded to the frame, using a 10 mm socket.
- Pull or pry the jounce bumpers out of the cup with a screw driver once the bolt has been removed.



3A

### 4 ASSEMBLING THE AIR SPRING

- Set a roll plate (H3) over the top of the air spring (See photo 4A).
- NOTE:** The rounded edge of the roll plate (H3) will be towards the bellows so that the bellows is seated inside both roll plates.
- Install the swivel fitting (H1) into the top of the air spring finger tight plus one and a half turns.
  - Install the upper bracket (see photo 4B) onto the air spring using four flat head screws (F1). Torque to no more than 20 ft-lbs.
  - Install the lower bracket (see photo 4C) onto the bottom of the air spring using the flat head screws (F1). Torque to no more than 20 ft-lbs.



4A

**NOTE:** The lower bracket has one corner cut off, this side of the bracket must point to the opposite side of the air fitting on the air spring assembly.

The figure 4C-4D below shows both left and right hand assemblies ready for installation.



4B



4C



4D

## 5 INSTALLING THE AIR SPRING ASSEMBLIES

- Install a large flat washer (F3) over the hex head bolt (F2) and thread the bolt onto the supplied wire to create a leader tool.
- Insert the bolt and washer through the slot on the side of the frame and through the slot on the bottom of the frame where the ABS line holder was removed. Repeat on the other side.

**NOTE:** The fittings on both air springs will be facing inboard.

- While raising the assembly, line up the bolt previously installed with the back hole on the bracket. Set the new ABS line holder over the bolt once the upper bracket is in place and cap with a flat washer (F4) and nylon locknut (F7). Leave loose at this time.

There are two ways to attach the front side of the upper bracket depending on whether you have a 5th wheel bracket running alongside of the frame or not.

### FOR VEHICLES WITHOUT A 5TH WHEEL BRACKET ALONG THE SIDE OF THE FRAME:

- Set the U-bolt (F8) over the frame and through the holes in the upper bracket forward of the axle.

**CAUTION:** DO NOT PINCH THE LINES ON THE LEFT (DRIVER) SIDE FRAME RAIL.

- Cap with flat washers (F4) and nylon locknut (F7). Position the front upper bracket onto the frame rail so the center hole is in the middle of the frame and there is sufficient clearance between the fitting and the stock jounce bumper cup.
- Torque the U-bolts to 10 ft-lbs. Repeat on the other side.



5A



5B



5C



5D

## 5 INSTALLING THE AIR SPRING ASSEMBLIES CONTINUED

### FOR VEHICLES WITH A 5TH WHEEL HITCH BRACKET THAT RUNS ALONGSIDE THE FRAME:

- Center the upper bracket in the middle of the frame rail, make sure there is sufficient clearance between the fitting and the stock jounce bumper cup, and drill a  $\frac{5}{16}$ " hole in the frame using the center hole in the front side of the upper bracket as a template. Install the Washer Head Self Tapping Screw (F10) in the hole.
- Torque to 15 ft-lbs. Repeat on the other side.
- Finish the upper bracket installation by torquing the rear bolt to 15 ft-lbs.

**NOTE:** use a  $\frac{1}{4}$ " ratchet with an extension and universal joint with a  $\frac{9}{16}$ " socket through the hole in the side of the frame to hold the rear mounting bolt for torquing.

**NOTE:** Long box models may require a short extension.



5E

### AIR SPRING ALIGNMENT

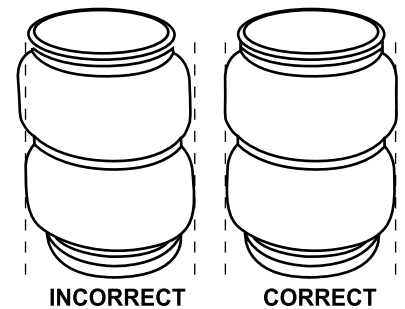

INCORRECT

CORRECT

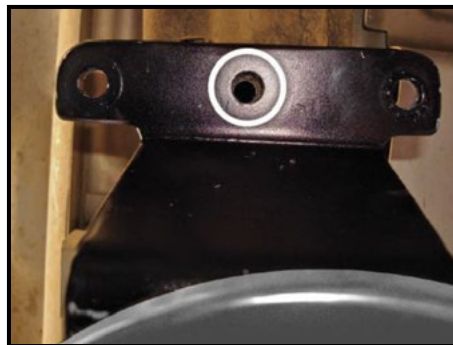

5F



5G



5H



5I



## 6 LOWER BRACKET INSTALLATION

Push the lower bracket (D) forward or back to center it over the jounce bumper strike plate. Insert a Hex Head Bolt (F6) through a Flat Washer (F4) and J-clamp (E). Install the J-clamp with the short end under the Jounce Bumper Strike Plate with the bolt through the lower bracket. Cap with a Flat Washer (F4) and Nylon Locknut (F7). Do this on the front and rear of the lower bracket and evenly torque both sides to 10 ft-lbs keeping the lower bracket centered over the jounce bumper strike plate on the axle. Repeat on the other side.

**NOTE:** It may be necessary on some models to slightly pull down the hard brake line on the rear right (passenger side) in order to install the lower bracket mounting hardware.



6A

## 7 EMERGENCY BRAKE CABLE MODIFICATIONS

- It will be necessary to re-locate the emergency brake cable that is held by a bracket on the top of the axle center carrier section of the rear end.
- Remove the top bolt that is holding the emergency brake cable bracket onto the center section of the rear end.
- Remove the bracket from the emergency brake cable and discard it.
- Install the large cable clamp over the emergency brake cable facing the rear with the hole down and attach to the rear end using the stock bolt previously removed.
- Bend the large cable clamp slightly to obtain clearance of the hard brake lines. Mounted on top of the axle.
- Insert the emergency brake cable into the large cable clamp.



7A



7B



7C

## 8 AIR LINE INSTALLATION

- Choose a convenient location for mounting the inflation valves.  
Popular locations for the inflation valve are:
  - A The wheel well flanges
  - B The license plate recess in bumper
  - C Under the gas cap access door
  - D Through the license plate

**NOTE:** Whatever the chosen location, make sure there is enough clearance around the inflation valves for an air chuck.

- Drill two  $\frac{5}{16}$ " holes to install the inflation valves
- Cut the airline assembly in two equal lengths

**CAUTION:** WHEN CUTTING OR TRIMMING THE AIR LINE, USE THE SUPPLIED HOSE CUTTER, A RAZOR BLADE, OR A SHARP KNIFE. A CLEAN, SQUARE CUT WILL ENSURE AGAINST LEAKS. DO NOT USE WIRE CUTTERS OR SCISSORS AS THEY MAY FLATTEN OR CRIMP THE AIR LINE CAUSING IT TO LEAK AROUND THE O-RING SEAL.

- Place a  $\frac{5}{16}$ " nut on the air valve. Leave enough of the inflation valve in front of the nut to extend through the hole, install a flat washer, and  $\frac{5}{16}$ " nut and cap. There should be enough valve exposed after installation—approximately  $\frac{1}{2}$ "—to easily apply a pressure gauge or an air chuck.

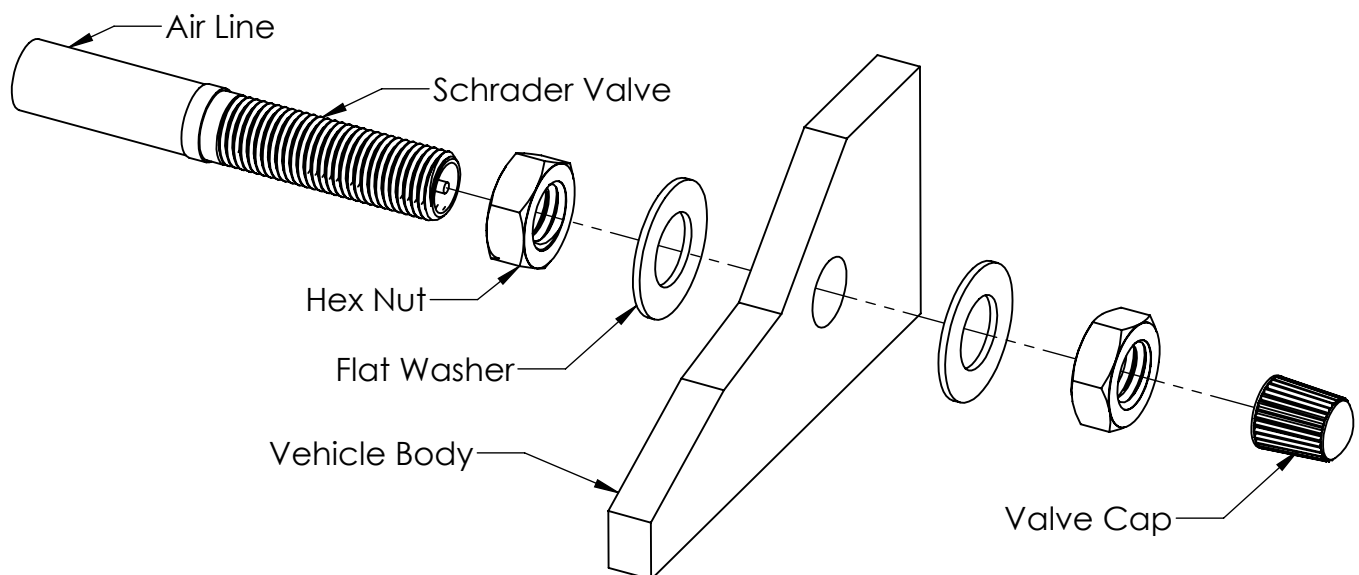

8A

- Push the inflation valve through the hole, install a flat washer, and another  $\frac{5}{16}$ " nut to secure it in place. Tighten the nuts to secure the assembly.
- Route the air line along the frame to the air fitting on the air spring. Keep AT LEAST 6" of clearance between the air line and any heat sources, such as the exhaust pipes, muffler, or catalytic converter. Avoid sharp bends and edges. Use the plastic tie straps to secure the air line to fixed (non-moving) points along the chassis. Be sure that the tie straps are tight, but do not pinch the air line. Leave at least 2" of slack to allow for any movement that might pull on the air line.

**NOTE:** Tie off the hose to the front hole of the upper bracket or U-bolt, depending on the mounting, with a tie strap to keep the hose away from the exhaust.

- Cut off the air line, leaving approximately 12" of extra air line. A clean square cut will ensure against leaks. Insert the air line into the air fitting. This is a push-to-connect fitting. Simply push the air line into the swivel fitting until it bottoms out ( $\frac{9}{16}$ " of air line should be in the fitting).

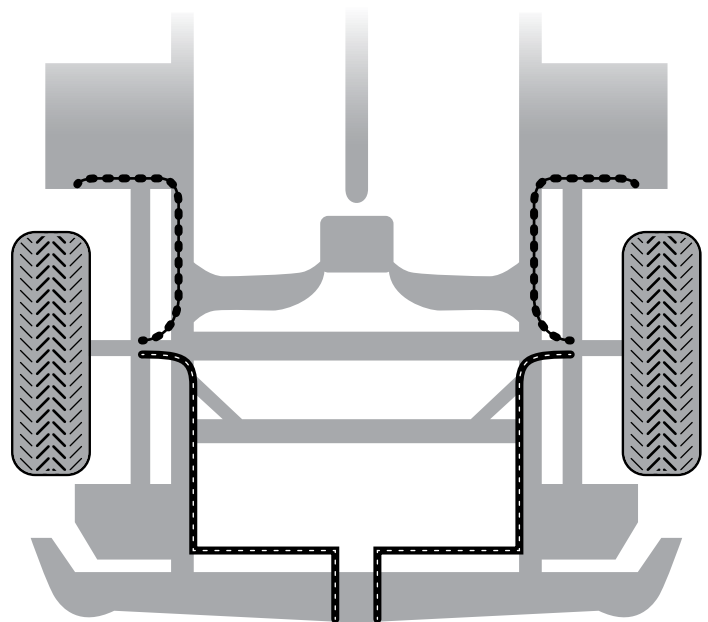

— AIRLINE (OPTION 1)  
- - - AIRLINE (OPTION 2)

8B

## 9 INSTALL THE HEAT SHIELD

- Bend the tabs on the heat shield (F15) so there will be the necessary  $\frac{1}{2}$ " dead space between the heat shield and the exhaust pipe when the heat shield is attached.
- Attach the heat shield (F15) to the exhaust pipe on the passenger side using two hose clamps (F16/F17). Each hose clamp holds a tab against the exhaust pipe. Make sure the heat shield is facing toward the air spring.

**NOTE:** The small worm gear clamps (F16) are intended to be used with an exhaust that is between 2.5-4.5" in diameter. The larger worm gear clamps (F17) are intended to be used with an exhaust that is between 4.5-6.5" in diameter.



9A

## 10 CHECK SYSTEM FOR LEAKS

- Inflate both air springs to 90 PSI, and then use a mixture of dish soap and water on all air line connections to detect any air leaks. Repair as necessary and retest.
- Inflate the air springs to a predetermined value, and on the following day recheck the pressure. If one or both the air springs have lost pressure, an air leak is present. The leak must be repaired, and then retested until no leaks exist.



10A

## 11 AFTER THE INSTALLATION IS COMPLETED, PLEASE REMEMBER:

- Install the wheels, and torque the fasteners to the manufacturer's specifications.
- Re-torque all the fasteners after the first 500 miles of driving.
- For safe and proper operation, never operate the vehicle under the minimum of 10 PSI or over the maximum of 100 PSI. Staying within the pressure limit will ensure maximum air spring life. Failure in doing so may result in a void warranty (see Note below).