

Installation Manual

PACBRAKE®



HP10126/HP10128/HP10158 KIT



*HP10126: Toyota Tundra 2WD/4WD**

*HP10128: Toyota Tundra 2WD/4WD**

*HP10158†: Toyota Tundra 2WD/4WD**

† Fits vehicles with Jounce Bumper 1" below frame

* See application guide for proper fitment.

Thank you and congratulations on the purchase of an AMP air suspension kit.

IMPORTANT:

This air suspension kit will not increase the GVWR (Gross Vehicle Weight Rating), as the GVWR is determined by the axle rating. Do not exceed the maximum load capacity listed by the vehicle manufacturer.

Before starting, ensure the application information on the front cover is correct for the make, model and year of the vehicle you are installing it on. Please read the entire installation manual prior to starting the installation to ensure you can complete the installation once started.

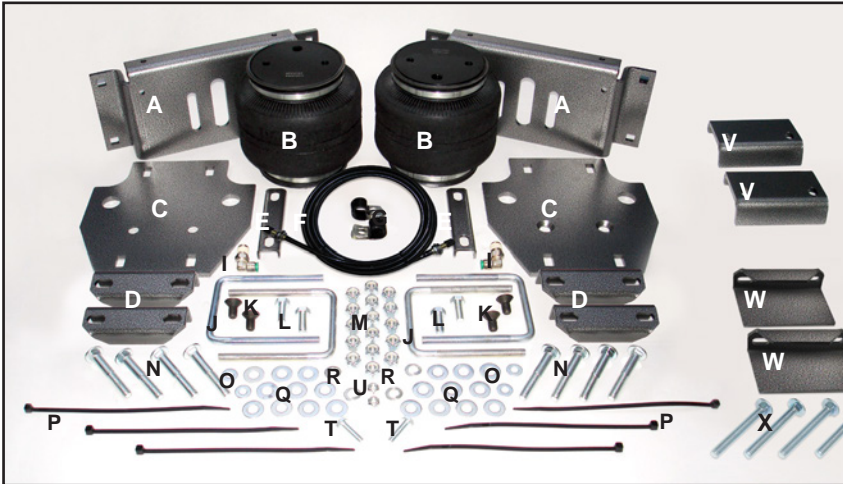

Make sure all the items shown in the photo are provided in your kit before starting the installation.

PLEASE NOTE:

The HP10128 kit is shown in the photo.

For the HP10126 kit (2001-2006 trucks), 2 clamps ("D") are removed and 2 clamps ("V") are added.

For the HP10158 kit (2001-2006 trucks with the upper jounce pad protruding 1" below the frame), 2 clamps ("D") are removed and 2 clamps ("W") are added.

KIT CONTENTS

A Lower Bracket (2)	HP0104
B Air Spring (2)	HP10083
C Upper Bracket (2)	HP0110
D Clamp (4) <i>*only 2 in HP10126 & HP10158 kits</i>	HP0112
E Bracket Spacer (2)	HP0113
F Air Line/Valve Assembly(1)	HP1344
G 5/8" Loop Strap, vinyl coated (2)	HP1006
I 90° Fitting (2)	HP1100
J U bolt (4)	HP1018
K 3/8"-24 x 3/4" Countersunk Capscrew (4)	HP1008
L 3/8"-24 x 7/8" Bolt (4)	HP1002
M 3/8"-16 Nylock Nut (16)	HP1000
N 3/8"-16 x 2 1/2" Carriage Bolt (8) [See <u>Note</u>]	HP1005
O 1/4" Flat Washer (4)	P02190
P Tie Straps (6)	C11618
Q 3/8" Flat Washer (20)	C653
R 3/8" Lock Washer (4)	C18007
T 1/4"-28 x 1" Bolt (2)	C10448
U 1/4" Nut Stover (2)	C11844
V Clamp (2) <i>*used in HP10126 kit only</i>	HP0111
W Clamp (2) <i>*used in HP10158 kits only with</i>	HP0124
X 3/8"-16 x 3" Carriage Bolts (4) [See <u>Note</u>]	HP1003

REQUIRED TOOLS

- 1/2", 9/16 open end or box wrenches
- Adjustable Wrench
- Torque Wrench
- 9/16 & 1/2 deep well sockets
- Heavy Duty Drill (to drill for fill valves only)
- 5/16 drill bit (very sharp)
- 7/32" Allen Wrench
- Screw Driver, Flat Blade
- Razor Blade
- Air Compressor/Compressed Air Source
- Hoist or Floor Jack
- Safety Stands
- Safety Glasses
- Spray Bottle with Dish Soap/Water
- Sawzall or Hacksaw

Note: HP10158 kits only contain 4 - 2 1/2" long carriage bolts ("N") and 4 - 3" long carriage bolts ("X").

PREASSEMBLY OF THE AIR SPRINGS

- 1 Locate the 90° fittings and air springs provided, apply thread sealant to the threads, install the fitting into the port of the air spring.

Check the clearance between the outside of the frame and the inside of the tire, a minimum of 5" is required for air spring clearance.

Pacbrake recommends using a good quality anti-seize on all fasteners, this will reduce the chances of the fasteners corroding and help facilitate removal if required at a later date.

STEP 1

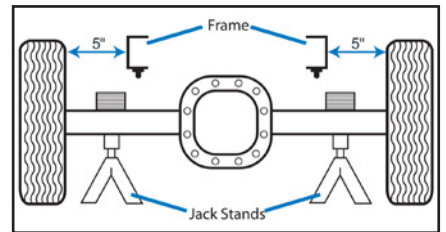

- 2 With the air spring resting on a bench as shown in the photo (fitting pointing up and on the opposite side to you) place the lower bracket over the fitting with the bent flange UP and towards you. Loosely install the 2 - 3/8" X 24 x 7/8" capscrews with lock and flat washers provided through the lower bracket into the two threaded holes of the air spring. Do not tighten the two capscrews as adjustment when installed will be required.

STEP 2

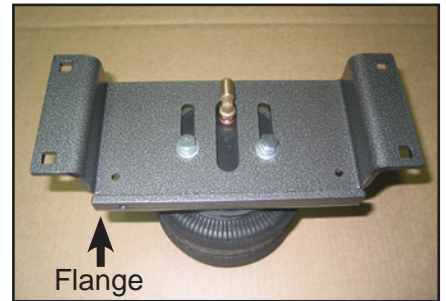

- 3 Turn the air spring and lower bracket assembly over. The bent flange of the lower bracket must be facing towards you. Place the upper mounting bracket on top of the air spring, with countersunk holes facing up and the angled sides towards you. Using the 2-3/8"-24 x 7/8" countersunk capscrews provided, torque to 20 ft-lbs, 27N.m. Attach the upper bracket to the air spring assembly and tighten the countersink capscrews securely.

STEP 3

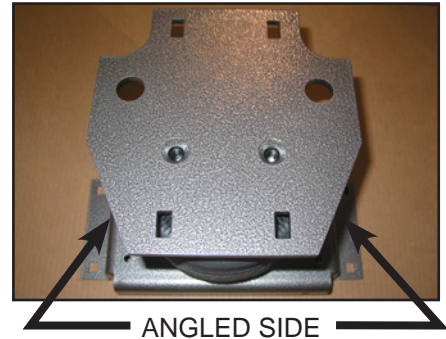

Repeat steps 1-3 for the other air spring assembly.

INSTALLATION ON THE VEHICLE

- 4** Park the vehicle on a flat level surface. Raise the rear axle with a floor jack enough to remove both rear wheels and attain a comfortable working height. Place two jack stands under the axle as shown in the photo. Lower the vehicle until the axle is supported by the jack stands.

Remove both rear wheels.

STEP 4



- 5** Using a sawzall or hacksaw, remove the jounce bumper by cutting the rubber portion off (as shown in the photo).

NOTE: It is permissible to remove the jounce bumper by loosening the axle U-bolts and slipping the jounce bumper assembly out from underneath the U-bolts. Take precaution if you follow this method of removal, as the axle can shift from its factory mounting point to the leaf springs.



BEFORE



AFTER

STEP 5

- 6** Remove the factory emergency brake cable support bracket in order to obtain clearance for the lower bracket. A supplied support for the emergency brake cable will be installed in step 13.

Ensure the lower air spring bracket is parallel to the frame flange directly above the upper air spring bracket. Lower bracket spacers are provided to shim the lower bracket if necessary, only in the HP10126, the spacers are installed with the legs against the leaf springs.



STEP 6

- 7** Loosely install the U-bolts provided around the leaf spring and up through the lower air spring mounting bracket holes and spacers if used. Install the flat washers and 3/8" nyloc nuts provided on the U-bolts.

- 8 Loosely install the upper outer clamp bracket onto the upper air spring bracket installing the 2-3/8" x 2 1/2"NC carriage bolts up from the bottom, use flat washers and nyloc nuts provided, the shorter leg of the clamp must be installed towards the frame. Repeat for the upper inner clamp.



UPPER OUTER

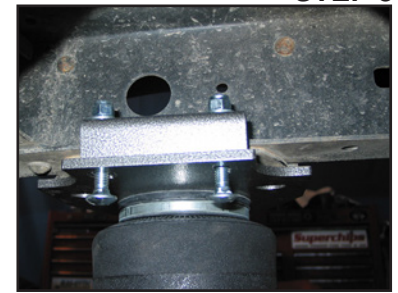

UPPER INNER

STEP 8

Note: The difference between the three kits is the upper bracket clamps and longer carriage bolts for the HP10158 kits.

HP10126 kits use pn# HP0111 outer clamp and pn# HP0112 inner clamp.

HP10128 kits use the same inner and outer clamps, pn# HP0112.

HP10158 kits use pn# HP0112 outer clamp and pn# HP0124 inner clamp, due to the increased length; 3" carriage bolts are provided.

HP10126

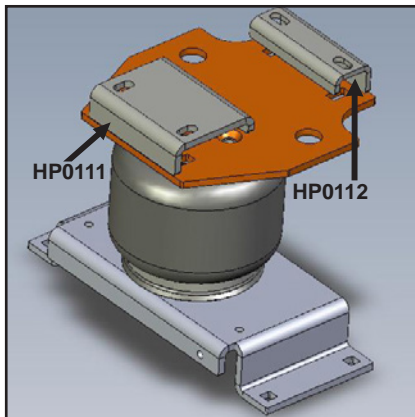

Driver's Side Assembly Shown

HP10128

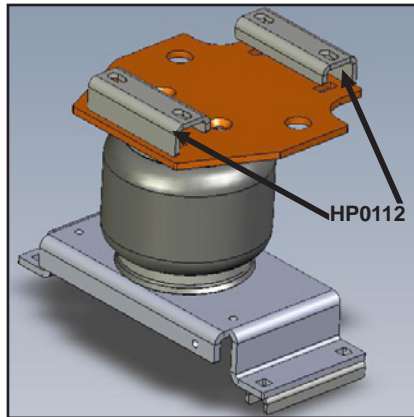

Driver's Side Assembly Shown

HP10158

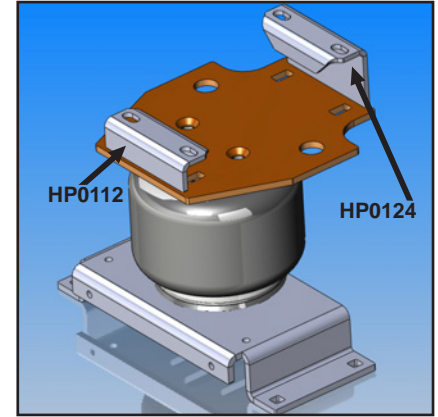

Driver's Side Assembly Shown

AIR SPRING ALIGNMENT

- 9 The upper air spring bracket clamps must be positioned with one leg on the frame and the other leg squarely on top of the upper bracket. Once this alignment is complete, torque the 2 inner and 2 outer clamp carriage bolts to 20 ft-lbs, 27 N•m.

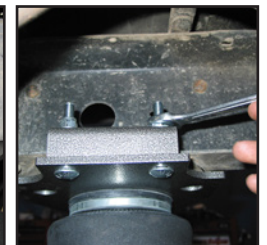

- 10 Position the lower air spring mounting bracket on the leaf spring. Align the lower end of the air spring to the top by moving the lower air spring bracket to the front or rear of the leaf spring. Once the alignment is correct, torque the 4 U-bolt nuts evenly to 16 ft-lbs.

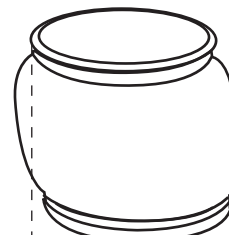

INCORRECT

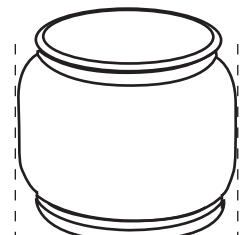

CORRECT

STEP 10

- 11** Then align the lower end of the air spring to the top by sliding the lower end in or out on the elongated holes in the lower bracket. Once alignment is correct, torque the lower air spring to bracket capscrews to 20 ft-lbs, 27 N•m.



STEP 11

- 12** Cut off the threaded portion of the U-bolts above the nyloc nut.



BEFORE



AFTER

STEP 12

- 13** Install the Adel clamp provided around the emergency brake cable, using the 1/4-28 x 1 bolts flat washer and nyloc nuts provided, fasten the Adel clamp to the forward hole in the top of the lower bracket (as shown in the photo).

Repeat steps 4-13 for the other air spring assembly.



STEP 13

AIRLINE INSTALLATION

- 14** Provided in the basic air spring kit are two fill valves, the most common place to install them is to replace the license plate fasteners with the fill valves. Alternatively, two holes can be drilled in a convenient location. Install one airline provided, route the nylon hose to an air spring fitting, cut the hose and connect to the air spring fitting. Repeat with the other fill valve. Secure airlines with the tie-straps provided away from moving items and heat sources.

If an in cab inflation kit is being installed, follow the instructions provided with it.

NOTE: This kit contains push to connect fittings, using scissors or wire cutters to cut the nylon airline will distort the line and cause the connection to leak. THE AIRLINE MUST BE CUT OFF SQUARELY WITH A SHARP RAZOR KNIFE. Moisten the end of the airline prior to inserting it into the fitting and push it in until it stops.

IMPORTANT! Check all fasteners are torqued to specifications



STEP 14

LEAK CHECK

- 15** Inflate both the air springs to 90 PSI. Use a dish soap and water mixture on all airline connections to detect air leaks. Repair as necessary and retest. Inflate the air springs to a predetermined value and then the following day recheck the pressure. If one or both of the air springs have lost pressure, a leak is present. The leak must be repaired and then tested until no leaks exist.
-

STEP 15



OPTIONAL ACCESSORIES

Pacbrake offers an optional dual needle air gauge to monitor the pressure in each spring from the vehicles cab. Pacbrake offers in-cab inflation kits to adjust the air spring pressure from the comfort of the driver's seat. Pacbrake offers a full line of air compressors, air tanks and solenoids to control your air spring system.

OPERATING YOUR VEHICLE WITH PACBRAKE AIR SUSPENSION

Air springs have minimum and maximum pressure requirements. Never operate your vehicle with less than 10 PSI in the air spring and never inflate the air springs over 100 PSI. Damage to the air springs will result.

Check the air pressure in the air springs daily for the first couple of days to ensure a leak does not develop. The air springs are designed to maintain the vehicles stock ride height with a load. Do not use the air springs as a means to lift the vehicle with no load. A rough ride will result.

NOTE: Retorque fasteners after the first 500 miles of driving.

SERVICING YOUR VEHICLE WITH PACBRAKE AIR SUSPENSION

When lifting the vehicle with a floor jack or hoist on the frame, never allow the air spring to limit the travel of the axle. Try to always jack the vehicle on the axle. Suspending the axle with the air spring limiting the axle travel will damage the air spring and void the air spring warranty.