

# Installation Manual

**PACPRO**<sup>®</sup>  
PERFORMANCE PARTS by PACBRAKE



## GOVERNOR SPRING KITS

**1994-1998 12 Valve Cummins**  
*(with P7100 Injection Pump)*



**PLEASE NOTE: THIS KIT IS NOT LEGAL FOR SALE OR USE IN CALIFORNIA.  
THIS KIT MAY NOT MEET EMISSION STANDARDS FOR YOUR AREA.  
CHECK YOUR LOCAL REGULATIONS PRIOR TO INSTALLING.**

**Thank you for your purchase of a Governor Spring Kit**

The purpose of this governor kit is to increase the maximum engine RPM and enhance throttle response when towing.



**PLEASE NOTE: THIS KIT IS NOT LEGAL FOR SALE OR USE IN CALIFORNIA. THIS KIT MAY NOT MEET EMISSION STANDARDS FOR YOUR AREA. CHECK YOUR LOCAL REGULATIONS PRIOR TO INSTALLING.**

**CAUTION:** Engines intended to be operated over 3200 RPM should have heavy duty intake & exhaust valve springs installed: Pacbrake Part # C11899 (6 for exhaust & 6 for intake), which are included in the below kits:

**GOVERNOR SPRING KIT | HP10029**

GOVERNOR SPRING KIT.



**SPRING KIT | HP10246**

6 HD VALVE SPRINGS & GOVERNOR SPRING KIT.



**SPRING KIT | HP10245**

12 HD VALVE SPRINGS & GOVERNOR SPRING KIT.



**PREMIUM KIT | HP10244**

6 HD VALVE SPRING WITH 6 VALVE COVER GASKETS, 6 HOLD DOWN BOLT SEALS & GOVERNOR SPRING KIT.



**PREMIUM KIT | HP10243**

12 HD VALVE SPRING WITH 6 VALVE COVER GASKETS, 6 HOLD DOWN BOLT SEALS & GOVERNOR SPRING KIT.

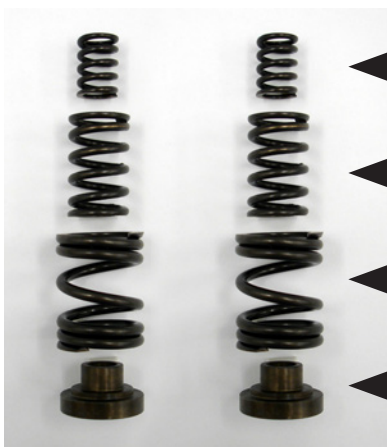

← Add these springs for 4000 RPM applications

← These springs required for both 3000 RPM and 4000 RPM installations.

← These springs required for both 3000 RPM and 4000 RPM installations.

← New spring seats both 3000 RPM and 4000 RPM kits.



**PLEASE NOTE: THIS KIT IS NOT LEGAL FOR SALE OR USE IN CALIFORNIA.  
THIS KIT MAY NOT MEET EMISSION STANDARDS FOR YOUR AREA.  
CHECK YOUR LOCAL REGULATIONS PRIOR TO INSTALLING.**

**Please read the entire installation manual before starting the installation, make sure you have a good understanding of all of the procedures and tools required to ensure customer satisfaction. If you are unsure about the installation, have a qualified mechanic do the installation.**

## REQUIRED TOOLS

- 7/16" deep socket
- 7/8" socket
- 10mm six point socket
- 8mm six point socket
- Ratchet and extensions to fit the above sockets
- 8mm allen wrench
- Pliers
- Pencil magnet
- Vernier calipers
- Flat blade screwdriver, med. to large size
- Long thin flat blade screwdriver
- Clean shop towels
- Fender covers or blanket to protect the fenders
- Metal marker

### IMPORTANT!

**Clean the engine thoroughly around the injection pump prior to any disassembly, it is imperative no dirt or foreign material enter the injection pump.**

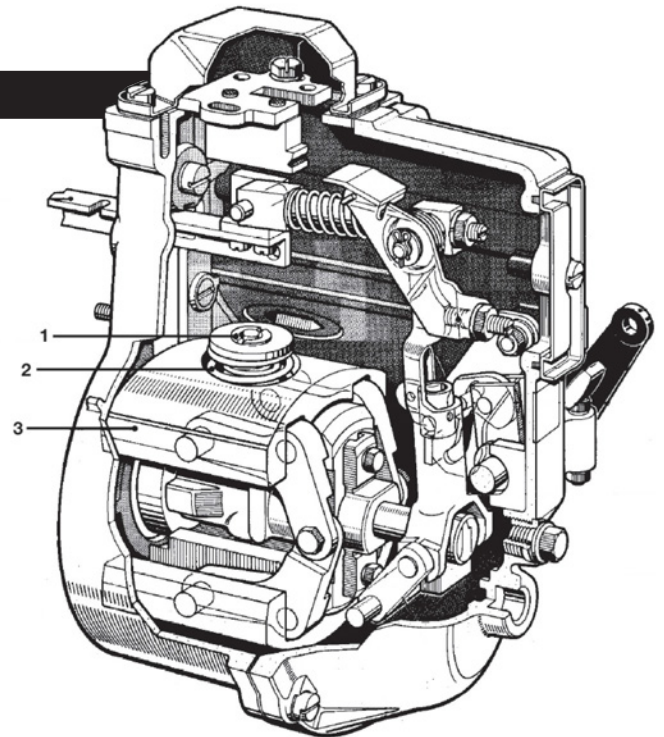

1= Adjusting Nut 2= Governor Spring 3= Flyweight

## Installation

- 1 Automatic transmission vehicles must be in PARK and manual transmission vehicles must be in NEUTRAL, both must have the parking brake applied.
- 2 Install fender covers or a clean blanket over the driver's side fender.
- 3 Disconnect both negative battery terminals.

- 4 Loosen the lower clamp on the upper air intake hose using a 7/16" socket, allow the clamp to slide down the air intake pipe.
- 5 Loosen and remove the 5 capscrews securing the air intake horn to the engine using the 10 mm six point socket. Also remove the dipstick clamp.

**Note:** These capscrews are different lengths make a note of their original positions.

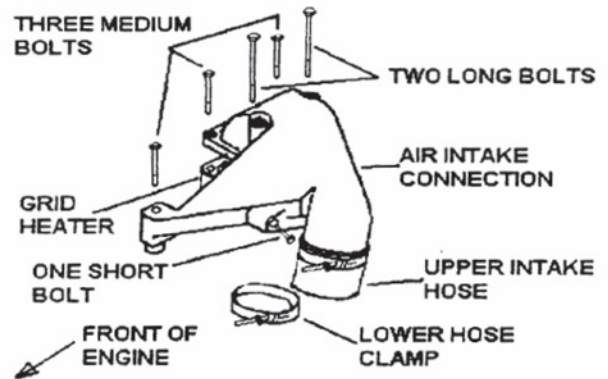

**DRIVERS SIDE VIEW OF INTAKE CONNECTION**

- 6 Carefully remove the air intake horn, be careful not to damage the gasket. In most cases the gasket can be reused, if damaged it must be replaced.
- 7 Using clean shop towels, cover the air intake tube and the manifold opening.

- 8 Three capscrews secure the fuel shut off solenoid and bracket to the injection pump, two on top and one at the back, all three need to be removed.

Remove the solenoid rod retaining clip, remove the rod from the linkage.

- 9 Once the solenoid is removed you will see a plug nut (as shown in Fig. 106), using a 7/8" socket loosen and remove this nut. It will be necessary to hold the linkage over to one side to attain clearance to remove the nut.

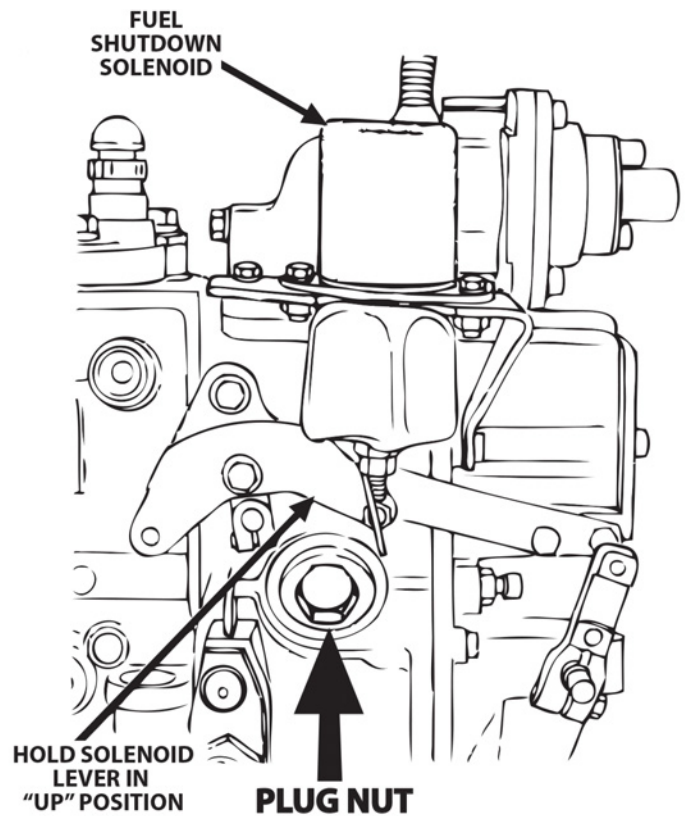

**Fig. 106 Fuel Shutdown Solenoid Lever in Up Position**

- 10 Rotate the engine until the governor spring adjustment nut is visible, then center it in the solenoid hole. Mark the position of the nut.



- 11 Using Vernier calipers measure the distance from the top of the governor stud to the top of the governor spring adjustment nut.

Record this measurement, it is required for reassembly.

It should be between .040" and .050".

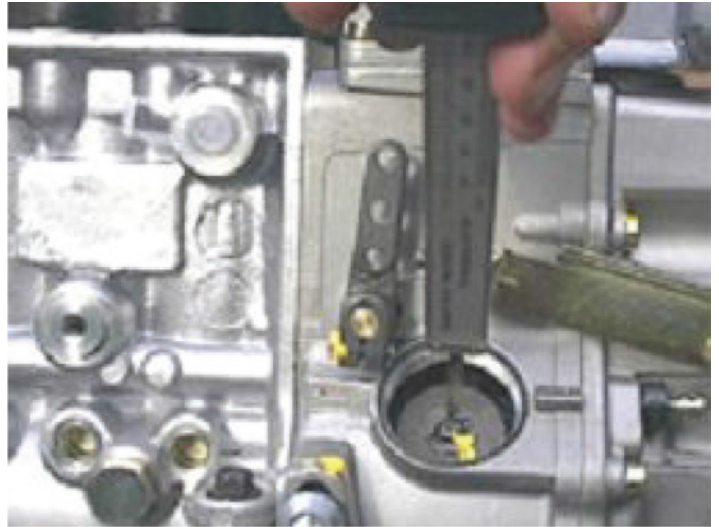

- 12 Using a long thin flat blade screwdriver unscrew the nut, place the end of the pencil magnet on the nut to prevent it from falling into the engine.

**CAUTION: LEAVE THE LARGE OUTER SPRING IN PLACE, it has shims on the bottom that must stay in place.**

*Use extreme caution when removing the stock springs, the springs have shims on the bottom which can fall into the injection pump. These shims are not necessary with the replacement springs supplied and must be removed carefully.*



- 13 Remove only the inner springs, shims and lower spring seat.
  
- 14 Install the new lower spring seat supplied, then the replacement inner springs:
  - **2 for 3000 RPM Kits**
  - **3 for 4000 RPM Kits**

Install the upper spring seat and retaining nut. Adjust the nut to the specification determined in Step 11.
  
- 15 Rotate the engine until the 2nd governor spring adjustment nut is visible, then center it in the solenoid hole. Mark the position of the nut.
  
- 16 Repeat Steps 11 through Step 14.
  
- 17 Install the plug nut, fuel solenoid, bracket and solenoid linkage .
  
- 18 Remove the towels covering the air intake tube and intake manifold opening.
  
- 19 Install the intake manifold and gasket.
  
- 20 Install the air intake hose.
  
- 21 Install the negative battery terminals.
  
- 22 Start the engine, allow to idle, check idle RPM. It is normal for the idle RPM to increase by 50 RPM after installing this kit. The idle RPM is adjustable by the idle adjustment screw.