

- Reliable and safe emergency shut down for diesel engines
- Simple pull cable activation method, with operator friendly manual reset
- Aluminum flap and housing for durable seal and low weight
- Designed for challenging thermal applications
- Wide range of sizes available
- Robust design; Tested to 18.6 gmrs vibration cycle
- Cycle tested 7300 actuations (2 times a day for 10 years)
- Components corrosion tested to ASTM B117, 96hrs Salt Fog
- Corrosion resistant pull cable



Product Description

Maximum Intake Boost Air Pressure
Continuous Intake Air Temperature
Ambient Temperature Range

2.76 bar (gauge) [40 psig]
-67°C to 200°C [-40°F to 392°F]
-40°C to 120°C [-40°F to 248°F] (valve body)

Resting Position
Activated Position

Valve open
Valve closed

Standard Mounting Options
Pipe Sizes Supported

Hose to hose
Ø44.5 mm to 70 mm [Ø1.75 in to Ø2.75 in] (more sizes available per request)

Physical Characteristics

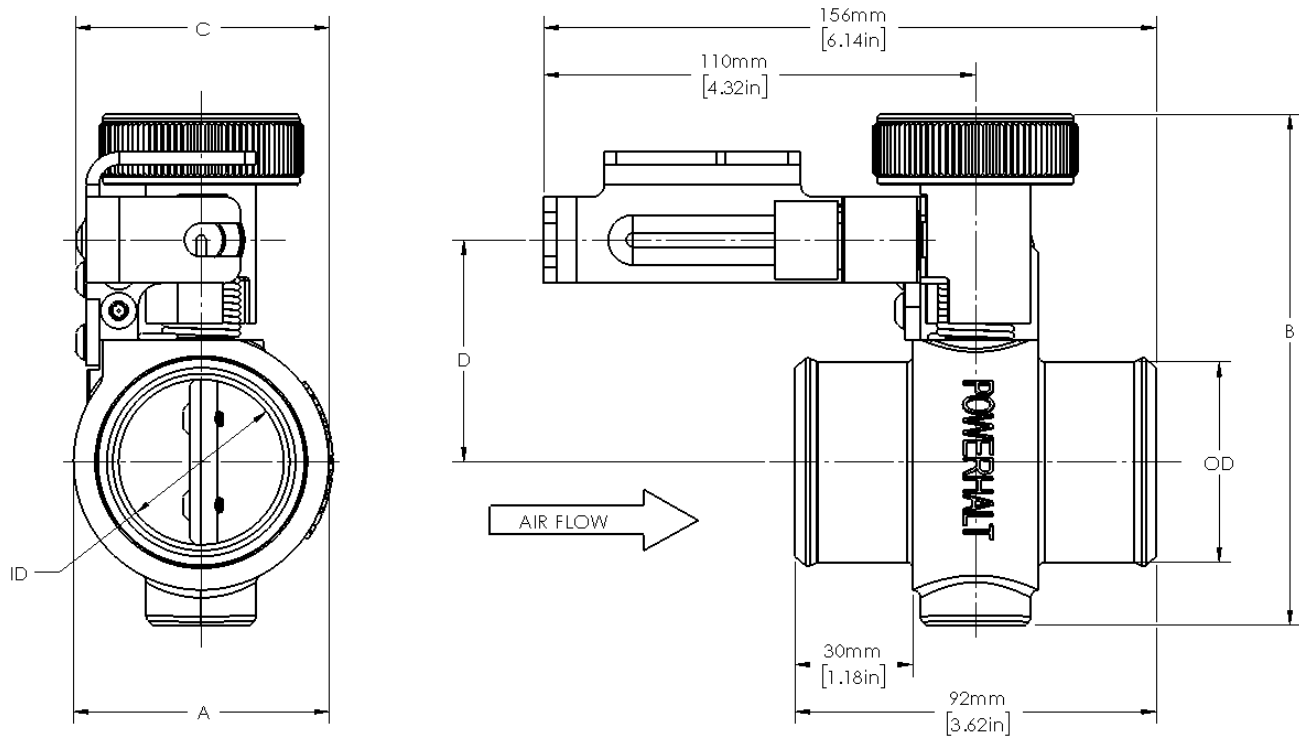

Nominal Valve Size [OD]	Valve Core Dimensions					Weight
	Bore [ID]	Housing OD [A]	Height [B]	Width [C]	Trigger [D]	
44.5 mm [1.75 in]	35.5 mm [1.40 in]	65 mm [2.56 in]	129.8 mm [5.11 in]	61.9 mm [2.44 in]	57 mm [2.22 in]	1.5 kg [3.3 lb]
51 mm [2.0 in]	42 mm [1.65 in]	65 mm [2.56 in]	129.8 mm [5.11 in]	61.9 mm [2.44 in]	57 mm [2.22 in]	1.5 kg [3.3 lb]
57 mm [2.25 in]	48 mm [1.89 in]	65 mm [2.56 in]	129.8 mm [5.11 in]	61.9 mm [2.44 in]	57 mm [2.22 in]	1.4 kg [3.1 lb]
64 mm [2.5 in]	55mm [2.17 in]	81.5 mm [3.21 in]	135.9 mm [5.35 in]	70.1 mm [2.76 in]	59.5 mm [2.34 in]	1.6 kg [3.5 lb]

Pull Cable Activation

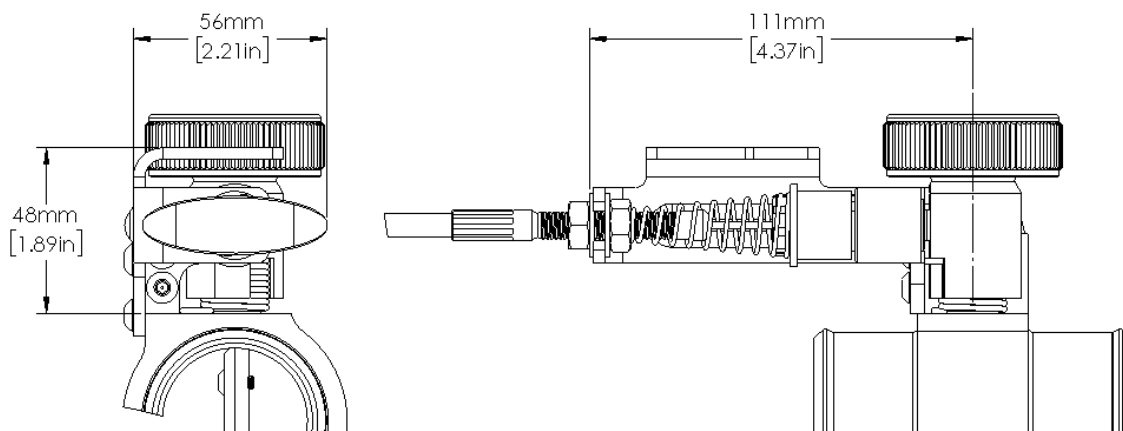

Minimum Cable Activation Pull Force	50 N [11.2 lbf]
Minimum Stroke for Activation	12 mm [0.47 in]
Activation	Pull to shut valve

Pull Cable

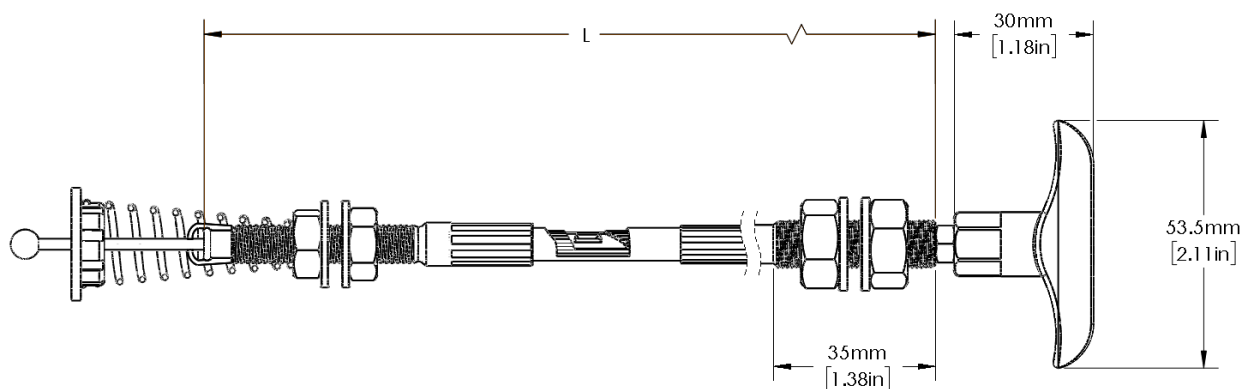

Minimum Cable Bending Radius	90 mm [3.54 in]					
Cable Lengths [L]	mm	610	1220	1830	2440	3050
	ft	2	4	6	8	10
Default Position	Handle retracted					
Cable Weight (Reference)	0.29 kg [0.64 lb] for 1830 mm [6 ft] Length					
Total degrees of all bends	360° maximum					
Through-hole size	11 mm [7/16 in]					
Ambient Temperature Range	-40°C to 85°C [-40°F to 185°F]					

Hoses

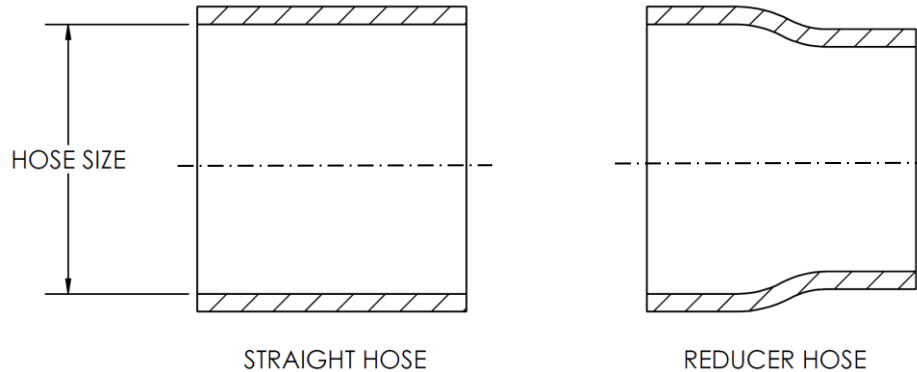

Temperature Rating	-55°C to +175°C [-67°F to +347°F]
Pressure Rating	Conforms to SAE J20 (20R1 HD SW)
Hose Sizes	44.5 to 70 mm [1.75 to 2.75 in]

Clamps

Description	Clamp, spring loaded constant tension gear/SAE J1508 Type SLHD	
SAE Sizes	#262	#312
Size Range	44.5 mm to 66.7 mm [1.75 in to 2.625 in]	54 mm to 79.4 mm [2.125 in to 3.125 in]
Installation Torque	8.5 Nm [75 in-lbf]	

Applications

- Lighting Units
- Bulk Haulers
- Grain Processing Plants
- Refinery Processing
- Fueling Vehicles
- Pump Trucks
- Ambulances
- Tankers
- Cranes
- Vehicles
- Tow Vehicles
- Fire Trucks
- Lighting Trucks
- Power Generators
- Forklifts
- Underground Equipment
- Support Vehicles
- Vacuum Trucks
- Frack Trucks
- Drilling Rigs
- Work Boats
- Barges
- Welders

Notes:

All information contained in this document is for reference only, subject to change without notice.

PRODUCT LINE OPTIONS

PH1



- » 1.75" to 2.5" sizes available
- » Compact and lightweight
- » Low maintenance, pull cable valve

PowerHalt's PH1 is a cost-effective solution for your safety needs. This option is recommended when the operator works in close proximity to the equipment.



PH2

- » 2.8" to 5.5" sizes available
- » Designed for extreme environments
- » Rigorously tested, zero leakage

PowerHalt's PH2 comes with various control and actuation options that cover a broad range of industry applications and requirements. Custom kits are available for most pick-up truck applications.



PH3

- » 1.75" to 4" sizes available
- » Compact and lightweight
- » Maintenance free, Smart system

PowerHalt's PH3 offers hands-free operation with an electronic reset function as well as various control options.



PH5

- » 1.75" to 5" sizes available
- » Operator friendly controls
- » Rigorously tested

PowerHalt's PH5 is the newest member of the PowerHalt family. It is electrically activated and available in an automatic engine speed sensing mode or a manual control configuration.



Don't Gamble on
SAFETY

Diesel Engine Safety Overview



IS YOUR SITE AT RISK? IT'S YOUR OBLIGATION TO PROVIDE A SAFE WORK SITE

Oil and gas production, refining, petrochemical processing, and mining are all industries where flammable hydrocarbon emissions or leaks may occur in a diesel engine's operating environment.

If you work in or provide services to these industries and you are around a diesel engine, you need to be aware of the risk to your crew and equipment.

Diesel engines do not usually incorporate a throttle valve to limit air into the engine, as their speed is primarily driven by the rate of fuel flow. The risk occurs when the diesel engine is operating in an environment that contains airborne hydrocarbons or other combustibles. This can occur from any number of sources, such as gas pocket vents, fuel leaks, atomized oil spray, or even grain dust. In this state, the engine experiences uncontrolled combustion, which may lead to an overspeed condition and catastrophic engine failure or backfire. The risk continues to rise from there, as the engine's behavior can then translate to ignition of the local atmosphere, which has been shown to cause explosions. In addition to the potential for explosion, the equipment driven by the engine may also experience unpredictable behavior and become a risk to personnel in the vicinity.

Since the early 2000's, the North American oil and gas industry has seen dozens of deaths and hundreds of injuries related to diesel engine overspeed events. In that time period, the same industries have also lost hundreds of millions in equipment damage and financial losses. This is entirely preventable.

PowerHalt – Air Intake Emergency Shut off valve by Pacbrake will starve the engine of air: safely and effectively shutting it down, protecting your crew and equipment.



If you run a diesel engine it has the potential to ingest combustible vapors. **Emergency air intake shut-off valves (also known as positive air shut-off valves) are the only safe way to shut down your engine during runaway conditions.**

Your biggest challenge is to know your industry, application and risks...

The information below will help you define the industries and applications that can expose your diesel engines to these dangerous conditions:



INDUSTRY

- Oil & Gas
- Power Generation
- Transportation
- Petrochemical Processing
- Mining
- Fire Suppression
- Agriculture
- Marine
- Airport - Refueling
- Construction

APPLICATIONS

- Lighting Units
- Ambulances
- Lighting Trucks
- Underground Equipment
- Bulk Haulers
- Tankers
- Power Generators
- Grain Processing Plants
- Drilling Rigs
- Cranes
- Forklifts
- Work Boats
- Refinery Processing
- Vehicles
- Frac Trucks
- Barges
- Fueling Vehicles
- Tow Vehicles
- Support Vehicles
- Welders
- Pump Trucks
- Fire Trucks
- Vacuum Trucks



QUESTIONS AND CONSIDERATIONS

Is this application operated offshore or on ground?

- Offshore applications may have specific regulations for your equipment
- Corrosion is a concern for offshore applications so PowerHalt valves are all corrosion tested to ASTM B117 96Hrs Salt-Fog to ensure product longevity

Can manual reset be achieved easily and without placing workers at risk?

- Frequent safety checks may prove cumbersome when manually resetting the valve if it is difficult to access. Our electronic reset option is best suited to these applications
- Routing of the switch or pull cable is an important consideration to make. Pull cables are a great low cost option if your application and regulations allow

Does your system have a compressed air source?

- Pneumatically actuated valves require an air source of 60psig (minimum) to 145 psig (maximum)

Does your engine require dual shut-off valves? (This changes the specification for control)

- Large V-engines may require two or more shut-off valves
- The automatic reset option is recommended to prevent incidents where only one valve is re-opened after a shutdown, preventing engine damage

Does your application require auxiliary/multiple sources for activation in case of emergency?

- The PowerHalt PH3 series can incorporate multiple auxiliary inputs from external sources for activation of the shut off valve in the event of an emergency
- Ideal for secondary emergency monitoring systems as well as multiple locations for manual override input

VALVE INSTALLATION LOCATION

In order of preferred location to least preferred

- 1st POST INTERCOOLER**
 - Low Plumbing Leakage Risk
 - Moderate Charge Air Temperature
 - Fast Shutdown Response Time
- 2nd POST TURBO**
 - Moderate Plumbing Leakage Risk
 - High Charge Air Temperature
 - Moderate Shutdown Response Time
- 3rd PRE TURBO**
 - High Plumbing Leakage Risk
 - Low Charge Air Temperature
 - Slow Shutdown Response Time

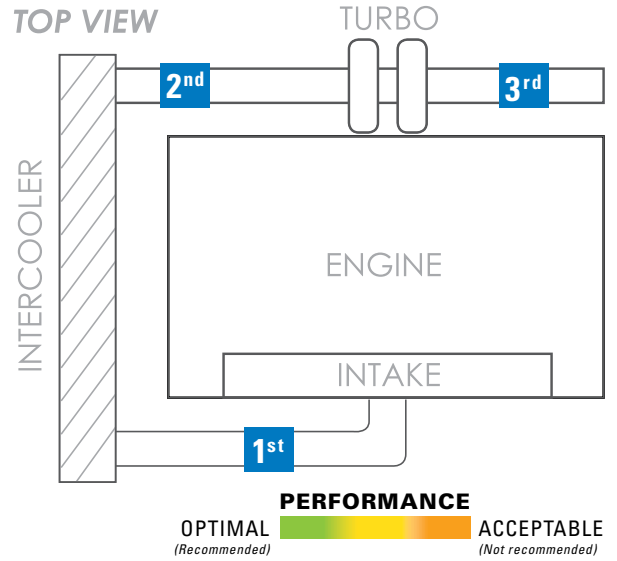

KIT CONTENTS

			<div style="display: flex; justify-content: space-around; text-align: center;"> <div style="writing-mode: vertical-rl; transform: rotate(180deg);">Controller</div> <div style="writing-mode: vertical-rl; transform: rotate(180deg);">Harness</div> <div style="writing-mode: vertical-rl; transform: rotate(180deg);">Membrane Switch</div> <div style="writing-mode: vertical-rl; transform: rotate(180deg);">Toggle Switch</div> <div style="writing-mode: vertical-rl; transform: rotate(180deg);">Magnetic Pick-Up</div> <div style="writing-mode: vertical-rl; transform: rotate(180deg);">Pneumatic Solenoid</div> <div style="writing-mode: vertical-rl; transform: rotate(180deg);">Pull-Cable</div> </div>						
	ACTUATION	RESET							
PH1	Pull-Cable	Manual							✓
PH2	Automatic Electric	Manual	✓	✓		✓	✓		
	Automatic Pneumatic	Manual	✓	✓		✓	✓	✓	
	Automatic Electric with Pull-Cable	Manual	✓	✓		✓	✓		✓
	Manual Electric	Manual		✓		✓			
	Manual Pneumatic	Manual		✓		✓		✓	
	Manual Electric with Pull-Cable	Manual	✓	✓		✓	✓		✓
	Pull-Cable	Manual							✓
PH3	Automatic Electric	Automatic/Manual	✓	✓	✓		✓		
	Manual Electric	Automatic	✓	✓		✓			
PH5	Automatic Electric	Manual	✓	✓		✓	✓		
	Manual Electric	Manual		✓		✓			



System Selection Guide

CONTROL OPTIONS

OPERATOR CONTROL (MANUAL – PH3)

Manually controlled shut-off valves are more cost effective than automatic systems. However, they should only be used when the operator works in close proximity to the engine and has a clear, safe, and accessible location for shutdown activation during an emergency.



POWERGUARD CONTROLLER (AUTOMATIC – PH2/PH3/PH5)

This system provides hands-free activation of the shut-off valve. It has additional safety benefits by utilizing our PowerGuard controller and magnetic pick-up. This system includes a manual override for direct operation of the shut-off valve, which allows the operator to perform routine safety checks and tests.



ACTUATION OPTIONS

ACTUATION OPTIONS

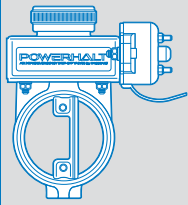
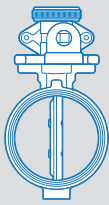
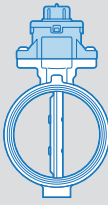
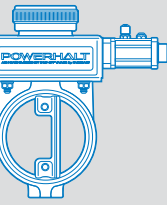
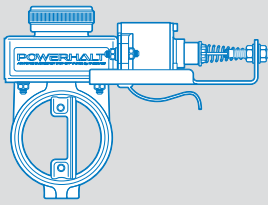
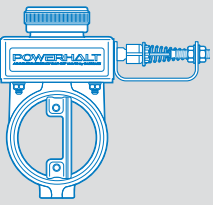
						
CONTROL OPTIONS AVAILABLE	Electric (Pull Solenoid)	Electric (Pull Solenoid)	Electric (Actuator)	Pneumatic	Electric (Pull Solenoid) + Pull-Cable	Pull-Cable
Operator Control (Manual)	✓	✓	✓	✓	✓	✓
PowerGuard (Automatic)	✓	✓	✓	✓	✓	
AVAILABLE WITH	PH2	PH5	PH3	PH2	PH2	PH1, PH2

RESET OPTIONS

MANUAL RESET (PH1, PH2 & PH5)

- The knob must be manually turned to reset the valve
- Some safety procedures require this option

ELECTRONIC RESET (PH3)

- The PowerHalt controller will electronically reset the shut-off valve, the operator will not have to turn a knob
- PH3 is available to be configured in manual reset mode, to be in compliance with CSA B621-14 and B622-14

COMPONENT OVERVIEW

POWERGUARD CONTROLLER



- Monitors engine speed and activates the shut-off valve, shutting down the engine, when the user-set trip speed is reached (automatic applications only)
- Digital micro processor

PULL CABLE WITH FACEPLATE



- Stainless steel high quality pull cables are pre-assembled for easy installation and safety
- Braided lines capable of a tight radius
- Red T-handle with large nameplate for easy location

MEMBRANE SWITCH



- Low profile membrane switch with trip, test and reset functions and LED lights

HARNESS



- Custom plug and play wiring harness with weather tight connectors

TOGGLE SWITCH



- Military style toggle switch with safety cover plate to prevent false trip hazards
- Provides a means to shut down the engine or to test the valve

MOUNTING KITS



- The mounting kit comes with the appropriate mounting group to include 2 hoses and 4 clamps, ensuring a successful installation into your system
- Adapters and piping are also available as separate options

MAGNETIC PICK UP



- Measures flywheel RPM and sends a signal to the PowerGuard controller to shut down the engine when engine runaway occurs
- Various thread sizes available
- Robust designs for extreme working environments

PNEUMATIC SOLENOID



- Auto vent to allow for quick release of air pressure
- Available in 12VDC and 24VDC
- OEM grade solenoid with millions in service to-date