

addendum

Installation Addendum
Dodge Ram 03-07 PRXB Kit

SUBJECT: Dodge Ram PRXB Kit Compressor Ground Wire Extension

This ground wire extension is to be installed in addition to the short ground wire from the compressor assembly.

1. Locate the bolt securing the compressor assembly ground wire. One ring terminal of the ground wire extension will be installed around this bolt. Remove the bolt.
2. Insert the bolt through one ring terminal of the ground wire extension and the ring terminal of the compressor assembly ground wire. There should be two ring terminals on the bolt, below the washer.
3. Re-install the bolt. Clock the ring terminals as necessary to ensure they sit flat. Torque to 32 ft.-lbs. (43.4 Nm).
4. Route the free end of the ground wire extension along the existing compressor wiring harness to the negative terminal of the battery.
5. Connect the ring terminal to the negative battery terminal.
6. Use the supplied zip ties to secure the wire away from heat sources and moving components.

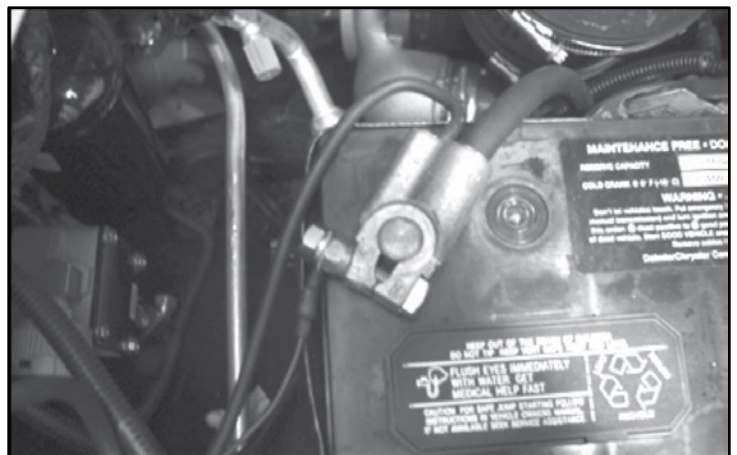
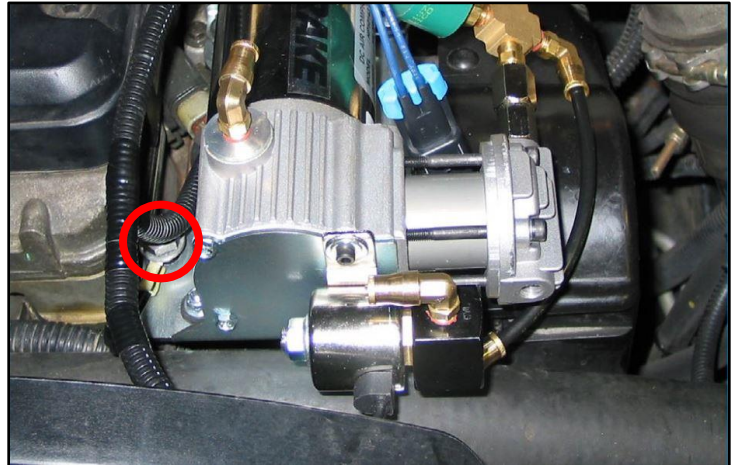

SUBJECT: IDENTIFICATION OF 48RE TRANSMISSION IN 2003 DODGE RAM

Early production 2003 Dodge Ram diesel trucks may be equipped with 2002 model year 47RE automatic transmissions from the factory. This model transmission requires a specific wire within the Pacbrake harness to be disconnected. This step is covered in the instruction manual.

Dodge provides 2 ways to identify the transmission in your vehicle by checking either the VIN number, body code plate or the equipment identification sticker.

TO CHECK YOUR VEHICLE

- BODY CODE PLATE** - Check the 3rd position (as shown in the illustration)
DG8 = Model 48RE - 4Speed Automatic | DGP = Model 47RE - 4 Speed Automatic

The Body Code Plate is located behind the headlight on the passenger side. The headlight does not need to be removed to access it. Standing in front of the vehicle, look at the left radiator support brace for the location (as shown in photo by arrow).

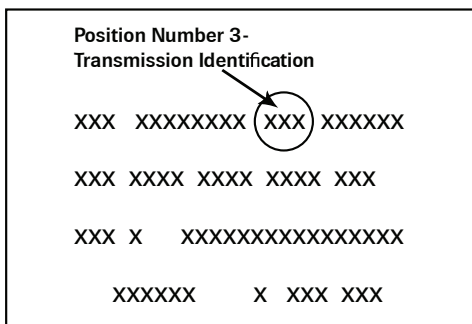

- EQUIPMENT IDENTIFICATION STICKER** - Check the 3rd description in left column (see illustration below)
DG8 = Model 48RE - 4Speed Automatic | DGP = Model 47RE - 4 Speed Automatic

The Equipment Identification Sticker is located inside the glove box.

| CHRYSLER CORPORATION | | EQUIPMENT IDENTIFICATION | | 4215966 |
|----------------------|--------------------------|--------------------------|-------------------|-------------------|
| MODELS | DH8H41 | XBS | V.I.N. | 3D7L38C95XXXXXXXX |
| | | | T.O.N. | 13317062 |
| CODE NO. | DESCRIPTION | CODE NO. | DESCRIPTION | |
| M9DV | TRIM CODE | PDM | PRIMARY PAINT | |
| DGB | All 4-Speed Automatic Tr | QDM | SECONDARY - PAINT | |
| DG8 | 4-Spd. Automatic 48RE Tr | | | |
| DHA | Lock-Up Torque Converter | | | |
| DH1 | Man Shift-on-the-Fly Tr | | | |
| DJQ | Front Axle, 9.25 | | | |
| DME | 3.73 Axle Ratio | | | |
| DRQ | 11.50 Rear Axle | | | |
| DSA | Anti-Spin Differential R | | | |
| | | ***** PAGE 1 OF 1 ***** | | CXXXXXXXX |

Installation

ADDENDUM

SUBJECT: Pyrometer Thermocouple Installation Warning

APPLICATION: Fixed Orifice and PRXB™ Exhaust Brakes
2003 and Newer Dodge Trucks with 3.5" and 4" Exhaust
***5.9 Liter Cummins Only**

IMPORTANT NOTICE

Do not install a pyrometer thermocouple in the back pressure test port, damage to the thermocouple will result.

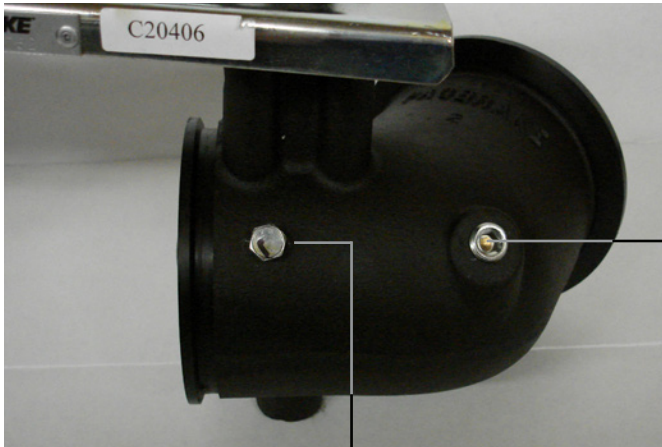

Pyrometer Thermocouple Port
1/4" NPT

Back Pressure Test Port
1/8" NPT