

Parts List

The RPK5-GM4101 includes everything you need for a professional installation of an aftermarket radio in your Camaro.

This kit contains:

1. Dash Kit
 - (x1) PAC HVAC Control Panel (Transfer of the factory HVAC knobs is required. See instructions below)
 - (x1) Support Bracket Spacer kit (needed in vehicles equipped with the factory MyLink radio)
 - (x2) Radio Mounting Brackets (One left and one right)
 - (x1) Pocket (For single din applications)
 - (x8) Radio Mounting Screws
2. RP5-GM4101 (Camaro specific radio replacement module)
3. Camaro specific antenna adapter (BAA-DIN22).
4. Rear camera retention cable for vehicles equipped with the MyLink system.
5. USB retention cable. This cable is compatible with vehicles equipped with the MyLink radios and vehicles equipped with the standard non-touchscreen radios. It will require that the cable be ran to the back of the center console.
6. AUX retention cable for 2010-2012 vehicles equipped with the standard non-touchscreen radios also equipped with a USB port.

Overview

The RPK5-GM4101 is a complete radio replacement kit with integrated climate control retention for the 2010-2015 Chevrolet Camaro. This kit utilizes the factory HVAC control knobs for a more factory look and experience. To add to the factory look and experience the exterior temperature display is retained by a small OLED display at the top of the kit retaining this valuable vehicle feature. This kit also includes all of the modules and cables needed to retain all of the important features of the factory system such as OnStar, factory warning chimes, factory Bluetooth, steering wheel mounted radio controls, factory reverse camera, factory amplifier (if equipped), AM/FM reception, factory AUX jack (if equipped) and the factory USB port (if equipped).

Table of Contents:	Page:
1. Factory Radio Removal -----	1-2
2. Disassembly of the factory HVAC control module -----	2-3
3. Assembly of the PAC HVAC control module -----	3-4
4. RP5-GM4101 Instructions -----	4-6
5. AUX & USB Cable Installation -----	7
6. Temperature Display Settings -----	7
7. Sub-Dash Preparation -----	7
8. Kit Assembly Instructions -----	8
9. Installation of the PAC HVAC control module -----	8-9

Removing the factory radio from the vehicle

1.1 - Apply the parking brake. Move the transmission shift assembly to the most rearward position possible. Use a flat bladed plastic trim tool and release the retainer tabs securing the front floor console front cover to the console assembly. Lift the cover (1) up and rearward making sure that the accessory power receptacle and the electronic traction control switch clears the transmission shift assembly. It may be necessary to pop them loose from the underside to achieve clearance. Disconnect the electrical connections.

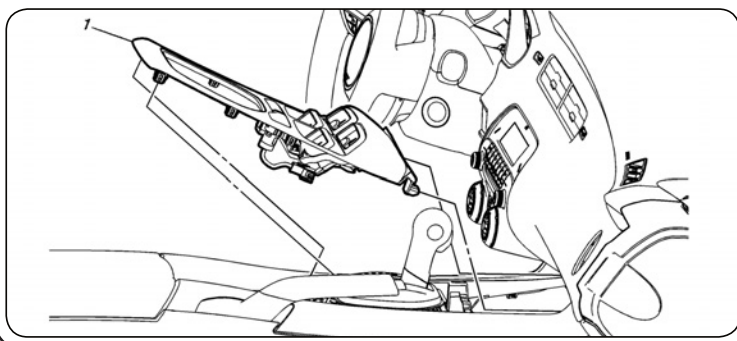

1.2 - Remove the 2 x 7mm bolts (1) securing the radio control assembly (2) into the dash. Then use a flat-bladed plastic trim tool in order to release the retainer clips securing the radio control assembly (2) to the instrument panel. Disconnect the electrical connections.

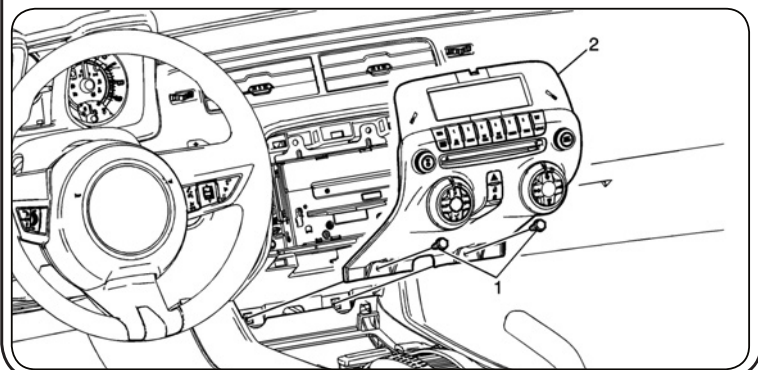

Removing the factory radio from the vehicle (cont.)

1.3 - Remove the 4 x 7mm bolts (1) securing the radio (2) into the dash. Slide the radio (2) to the rear and disconnect all electrical connections.

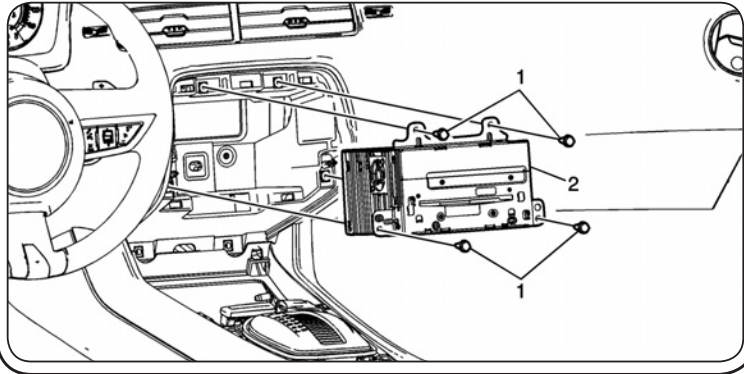

You can set the radio aside as it will not be used further. For the next section, you will be working with the factory HVAC control panel to utilize the HVAC knobs allowing for more of a factory experience when using the PAC RPK5-GM4101.

Proceed to the next section to begin disassembly of the factory radio control assembly.

Disassembly of the factory HVAC control panel

The following steps will aid you in the disassembly of the HVAC control panel so that the factory HVAC control knobs and supports can be reused in the PAC RPK5-GM4101 Integrated Kit.

2.1 - Remove the 2 Phillips head screws shown below.



2.2 - Pry outwards on the clips on either side of the plastic trim that surrounds the white connector.

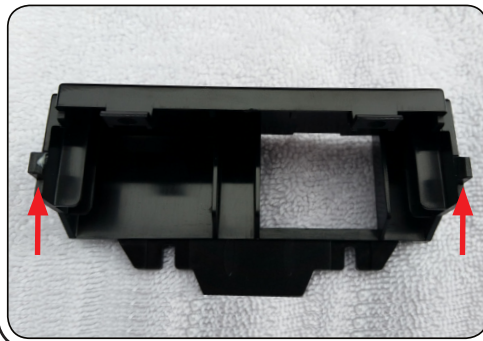

2.3 - Once the plastic trim is removed, locate the 16 pin connector shown below. Using a flat bladed tool, press in the grooves on both sides, pry upward and away from the circuit board, to release the connector.

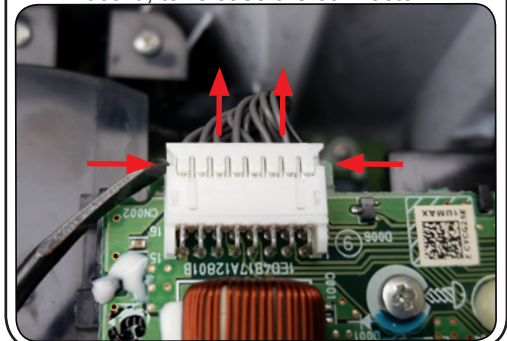

2.4 - Remove the 10 Phillips head screws shown below and remove the black plastic backing.



2.5 - Using a flat bladed pry tool remove two of the white fasteners off of the black plastic backing.



2.6 - Be sure to keep the screws separated as there are different lengths and diameters.



Disassembly of the factory radio control assembly (cont.)

2.7 - Remove the 12 Phillips head screws shown below.

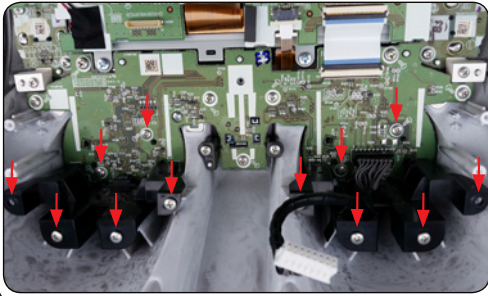

2.8 - Be sure to keep the screws separated as they will be used during the assembly stage later.



2.9 - After the screws have been removed, remove the HVAC knobs by pulling them from the front of the faceplate being careful not to bend the contacts on either end of the contact swiper on the backside of each of the knobs.



2.10 - Look inside the opening where the knobs were removed. Remove the 2 Phillips screws shown below. Do this for both openings.

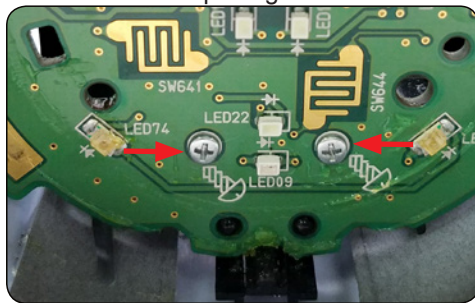

2.11 - Remove the 2 support brackets and keep handy as they will be used in the next step.

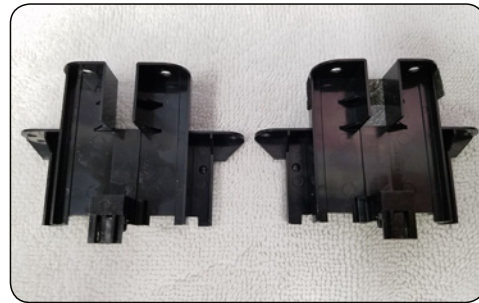

Assembly of the PAC HVAC control assembly

3.1a - Secure the 2 support brackets to the PAC HVAC control assembly using 4 of the same screws shown in disassembly step # 7. Do this to the back of each side. Be sure that the alignment tabs are seated properly in the circuit board to the front. See 3.1b if your vehicle is equipped with the factory MyLink radio. Otherwise proceed to 3.2.

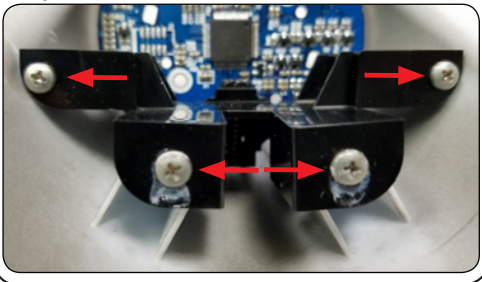

3.1b - In vehicles equipped with the factory MyLink radio you will need to use the supplied spacer kit and longer screws to secure the upper 2 ears of the support bracket to the PAC HVAC control assembly. The 2 lower ears will still use the factory screws to secure it to the PAC HVAC control assembly.



3.2 - Secure the 2 support brackets to the circuit board using the same screws removed from Disassembly step # 9. The screws will pass through the board and thread into the brackets via the holes defined below. Be sure that the alignment tabs are seated properly.

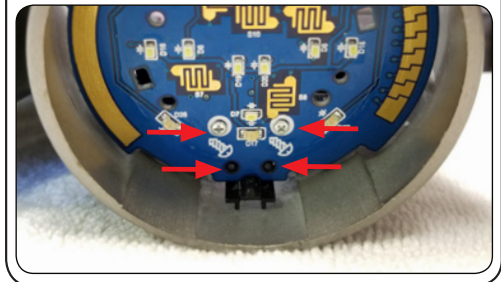

Assembly of the PAC HVAC control assembly (cont.)

3.3 - Position the knobs in the proper opening so that the buttons are straight and insert them into the opening. With **VERY LITTLE** force rotate them slightly left and right while pushing them towards the PCB. Once the alignment tabs are lined up they should click and lock into place. Use extra caution as the contacts could bend while rotating.



3.4 - Secure the knobs to the circuit board using the same screws shown in disassembly step # 7. The screws will pass through the circuit board and thread into the knobs via the holes defined below.

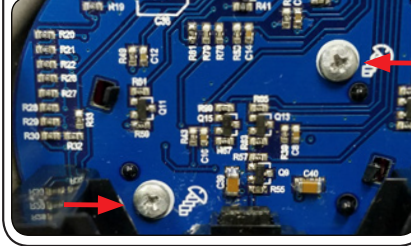

3.5 - Slide the white fasteners onto the two black posts at the top of the PAC HVAC control assembly.

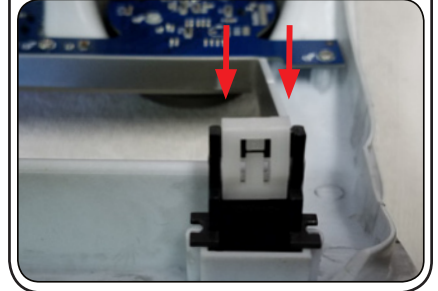

RP5-GM4101 Introduction & Features

The **RP5-GM4101** interface allows the replacement of a factory radio in the 2010-2015 Chevrolet Camaro. Using this interface will retain factory features such as OnStar, Bluetooth, steering wheel controls (SWC), AUX Audio, USB and warning chimes when the original radio is removed. Use of this interface also allows you to program two radio functions to each SWC button by using short press long press dual command functionality. The **RP5-GM4101** also provides data bus driven outputs such as retained accessory power (RAP), vehicle speed sensor (VSS), illumination, reverse trigger and parking brake.

RP5-GM4101 Important Notes

1. Once the radio has been removed, the vehicle settings which are normally selected through the factory radio can be accessed using the PAC Interface Updating Device (PAC-UP) along with downloading and installing the PAC Vehicle Settings program (for windows PC).
2. As in most radio replacements where the car has a separate Bluetooth module it is recommended that the phone(s) be "Unpaired" with the factory Bluetooth. This way the phone will always pair to the new radio.
3. The Answer/Voice & End/Mute buttons can be set to do the factory OnStar functions or given the ability to control the aftermarket radio. This option can be found in the PAC Vehicle Settings program mentioned above in note one. The default setting for these buttons is to control the factory OnStar. If these buttons are set to control the aftermarket radio, OnStar can still be accessed by using the mirror controls.
4. The radio select rotary switch on the side of the interface must be adjusted to the proper radio setting before plugging the interface into the vehicle (see below for setting chart).
5. The interface comes pre-programmed for all of the vehicles factory SWC functions and does not require programming unless you wish to re-assign the SWC functions or utilize the short press long press dual command functionality. The SWC can always be restored to default settings by pressing and releasing the program button on the side of the interface once and waiting 7 seconds for the LED to flash 4 times.
6. The LED will flash whenever a SWC button is pressed.

RP5-GM4101 Wiring Connection Chart

Aftermarket Radio Connections

Yellow	Battery +12v
Black	Ground
Red	Accessory Output
White	Front Left + input
White / Black	Front Left - input
Grey	Front Right + input
Grey / Black	Front Right - input
Green	Rear Left + input
Green / Black	Rear Left - input
Purple	Rear Right + input
Purple / Black	Rear Right - input
Blue	Not Used
Blue / White	Amplifier Remote Turn On

Light Green	Parking Brake Output (-)
Pink	Vehicle Speed Output
Orange / White	Illumination Output (+)
Purple / White	Reverse Output (+)
Brown Loop	Mute Loop - See Note Installation Step 4 on Page 6

SWC Connector

Blue / Yellow	Kenwood, or Newer JVC
3.5mm Jack	Alpine, JVC, Clarion, Pioneer, Sony, Boyo, Dual, Lightning Audio, Visteon, Jensen or Advent

Antenna Adapter

Blue	Power Antenna output from aftermarket radio
------	---

RCA Connectors (Main Connector)

Red	AUX Audio Retention Right
White	AUX Audio Retention Left

RCA Connector (Grey connector)

Yellow	Reverse Camera
--------	----------------

3.5mm Connector (Black connector)

3.5mm Jack	AUX retention for 2010-2012 vehicles equipped with a factory USB port.
------------	--

RP5-GM4101 Illustration / Schematic

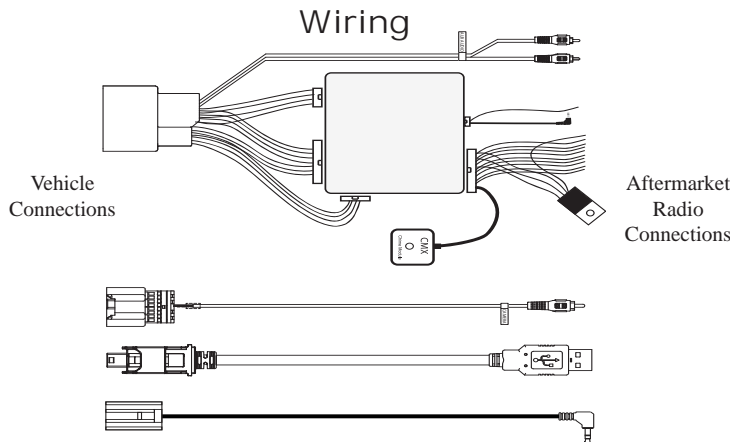

SWC Connection

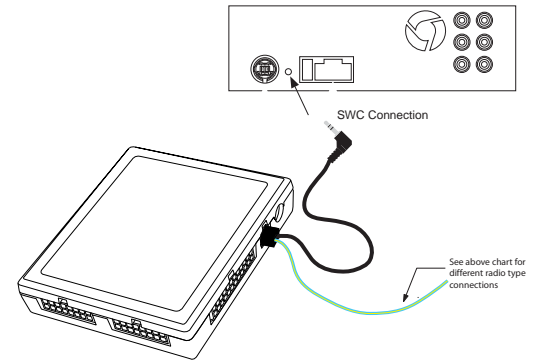

RP5-GM4101 Installation Steps

SET RADIO SELECT SWITCH



Alpine	JVC	Kenwood	Clarion / Nakamichi	Pioneer/Other	Sony	Fusion
1	2	3	4	7	8	9

Other = Advent, BOYO, Dual, Jensen, Lightning Audio, Rockford Fosgate & Visteon

1. The radio select rotary switch on the side of the interface must be adjusted to the proper radio setting before plugging the interface into the vehicle.
2. Make all connections as described in the chart on page 1.
3. Plug the CMX chime module in if necessary (If the vehicle chimes when the radio is removed the CMX is not necessary). **PLEASE NOTE:** In order to get the best possible sound out of the CMX please mount it in a place free and clear of any obstructions, preferably as close as possible to the bottom of the dash pointing down toward the floor of the vehicle.
4. The Mute loop (if not cut) will turn the accessory output off when an OnStar or Bluetooth call is made or received. If the aftermarket radio has a mute input cut this loop and connect the outer brown wire to the mute input.
5. Connect the SWC wire according to the chart on page 5 (aftermarket radio MUST support a wired remote input).
6. If you wish to reassign functions to the SWC follow the programming instructions in the next section.
7. Connect the proper AUX cables depending if your vehicle has the MyLink or standard non-touchscreen radios equipped with a USB port.
8. Connect the supplied USB retention cable. MyLink radios will have a mini USB cable behind the radio. In this case the USB-GM1 cable (sold separately) can be used. The supplied cable will need to be ran to the back of the factory USB port located at the rear of the center console.

RP5-GM4101 Default Steering Wheel Control Programming

IMPORTANT! The interface comes pre-programmed for the functions listed in the chart below and does not require programming unless you wish to re-assign the SWC functions or utilize short press long press dual command functionality. The SWC can always be restored to default settings by pressing the program button on the side of the interface once and waiting for the timeout.

The Mute/End button has two functions. Pressing this button for less than 1.5 seconds will initiate the mute command. Pressing this button for more than 1.5 seconds will initiate the end command. This dual function button can also be reprogrammed to whatever features the customer chooses.

Default SWC Button Assignments

	Alpine	JVC	Kenwood	Clarion/ Nakamichi	Pioneer	Sony	Fusion
Volume +	Volume +	Volume +	Volume +	Volume +	Volume +	Volume +	Volume +
Volume -	Volume -	Volume -	Volume -	Volume -	Volume -	Volume -	Volume -
Source	Source	Source	Source	Source	Source	Source	Source
Track +	Track +	Track +	Track +	Search +	Track +	Track +	Track +
Track -	Track -	Track -	Track -	Search -	Track -	Track -	Track -
Answer/Voice	Answer/OnStar Activation	Answer/OnStar Activation	Answer/OnStar Activation	Answer/OnStar Activation	Answer/OnStar Activation	Answer/OnStar Activation	Answer/OnStar Activation
Mute/End	Mute/Factory Bluetooth End	Mute/Factory Bluetooth End	Mute/Factory Bluetooth End	Mute/Factory Bluetooth End	Mute/Factory Bluetooth End	Mute/Factory Bluetooth End	Mute/Factory Bluetooth End





RP5-GM4101 Optional Steering Wheel Control Programming



If you wish to re-assign the SWC functions or utilize short press long press dual command functionality, the interface must be programmed in the specific order shown in the chart below. If you come across a function in the chart that your steering wheel does not have, or you do not want to program, press and release the program button on the side of the interface to skip that function. The LED will flash off and on confirming that you have successfully skipped that function and are ready to proceed to the next one.

Short Press Long Press Dual Command Functionality

This feature allows you to assign two aftermarket radio functions to each of the vehicle's SWC buttons. It can be used with as many of the buttons as the user likes or none at all. When this functionality is implemented, quickly pressing and releasing a SWC button will initiate the short press command, while pressing and holding a SWC button for longer than two seconds will initiate the long press command. Please note that all buttons except the Mute button do not have a long press command programmed by default. If you wish to assign dual command functionality to the SWC please follow the programming steps on the next page.

Optional Programming Order

	Alpine	JVC	Kenwood	Clarion / Nakamichi	Other 	Pioneer	Sony	Fusion
1	Volume +	Volume +	Volume +	Volume +	Volume +	Volume +	Volume +	Volume +
2	Volume -	Volume -	Volume -	Volume -	Volume -	Volume -	Volume -	Volume -
3	Mute	Mute	Mute	Mute	Mute	Mute	Mute	Mute
4	Preset +	Source	Source	Source	Preset +	Preset +	Preset +	Source
5	Preset -	Track +	Play	Search +	Preset -	Preset -	Preset -	Track +
6	Source	Track -	Track +	Search -	Source	Source	Source	Track -
7	Track +	Band/Disc +	Track -	Band	Track +	Track +	Track +	Audio
8	Track -	Preset/Disc -	Disc/FM +	Send/End	Track -	Track -	Track -	Power
9	Power	Select	Disc/AM -	Send	Band	Band	Band	
10	Enter/Play	Attenuation	Answer	End	Answer 	Phone Menu	Reject Call/Source (Bluetooth equipped radios only)	
11	Band/Program	Phone Receive	Voice Dial		END 	Answer Call	Answer/End Call	
12	Receive	Phone Reject	On Hook		PTT 	End Call		
13	End	Voice Dial	Off Hook			VR		
14	VR	Power	Mute (Multimedia units only)					
15			Preset +					

 - Advent, Boyo, Dual, Lighting Audio, Jensen, Rockford Fosgate & Visteon  - Jensen & Advent ONLY

Programming the SWC assignments

- Turn the key to the ignition position.
- Press and release the programming button on the side of the interface. The SWC LED will turn on solid.
- Within 7 seconds, press the button that is to be learned on the steering wheel. The SWC LED will turn off when the button is pressed. **At this point you have two options:**
 - For short press functionality:** Release the button within 1.5 seconds. The SWC LED will turn back on.
 - For long press functionality:** Hold the button until the SWC LED starts blinking. Release the button and the SWC LED will go back to solid.
- If you need to program more buttons, repeat step 3 for each additional audio function on the steering wheel.
- If you come across a function in the chart that your steering wheel does not have, or you do not want to program, press and release the program button on the side of the interface to skip that function.
- Once programming is completed, wait seven seconds. The SWC LED will flash three times indicating end of programming.
- Test the interface for proper functionality. Whenever a SWC is pressed the SWC LED on the interface should blink. If any function does not work, repeat the programming steps.

RP5-GM4101 Testing & Verification

- Turn the ignition on. The LED on the interface will turn on & the +12v accessory wire will turn on.
- Turn on the radio and check balance & fade.
- Verify that all SWC are functioning properly for both the aftermarket radio and OnStar. To adjust OnStar volume, press the OnStar button on the mirror then use the volume buttons on the SWC to adjust the level. The volume will raise a total of 8 times before returning to the original level.
- Pressing the OnStar® button on the rearview mirror will turn off the rear speakers and allow the OnStar® audio to be heard in the two front speakers. The OnStar® active LED will also turn on. When OnStar® disconnects, the radio will un-mute or turn back on and the OnStar® LED will turn off. Pressing the Mute/OnStar® button on the steering wheel for 1.5 seconds will also activate Onstar®.
- Turn off vehicle and remove key. RAP will be active and keep the radio on for 10 minutes, or until the driver's door is opened.
- The Accessory LED and radio will turn off when RAP turns off or the driver's door is opened.

RP5-GM4101 Product Updates (Firmware)

The RP5-GM4101 can be updated with new firmware as it becomes available using the PAC-UP interface updater (sold separately).



USB and AUX cable Installation

1. Use a flat bladed plastic trim tool and release the retainer clips securing the console's (1) right & (2) left side covers to the front floor console assembly.
2. Move the front seats to the forward most position.
3. Remove the 4 Phillips head bolts (3) securing the consoles rear cover (4) to the front floor console.
4. Remove the front floor console rear cover (4).
5. Remove the electrical connections from the back of the AUX and USB panel located inside the center console.
6. Connect the RPK5-GM4101-AUX-HAR and the RPK5-GM4101-USB-HAR (if the vehicle is equipped with factory AUX).
7. Route the new AUX and USB cables down the driver side and using a fish tape, route the cables up into the radio cavity.

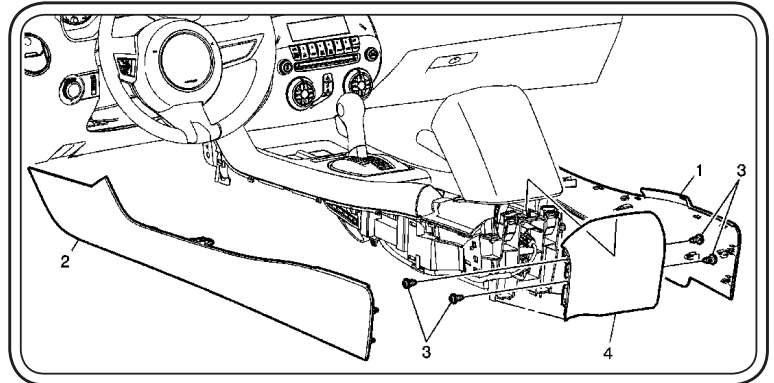

Sub-Dash Preparation

1. Locate the radio brain alignment tabs. Each side needs to be trimmed for clearance of the new HVAC panel



2. Remove the conical portion of the alignment tab.



3. When finished, the tabs should look like the one below.



Note: Some radios will require extra depth during installation. If you encounter this issue please follow the next two steps to modify the dash for extra clearance.

***Warning: Check for factory wiring harnesses around (including behind) this area before cutting. Use caution not to cut any of this wiring

1. Locate the factory radio module mounting hole towards the back of the dash opening.

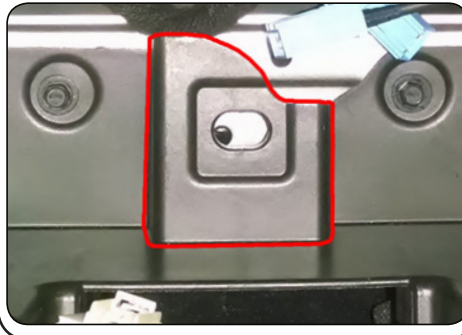

2. Cut and remove the portion that extends towards the front dash opening.

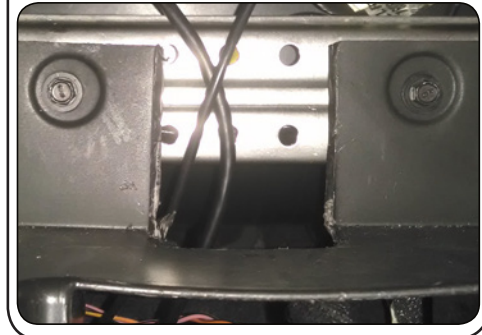

Kit Assembly Instructions (Single DIN)

Single DIN Mount Applications

1. Snap and lock each of the side brackets onto the pocket. FIG 1
2. Insert ISO mountable radio between the side mount brackets and loosely attach to sides of radio using screws provided with radio when possible or hardware included with kit.
3. Slide radio component forward or backward for desired look and tighten screws.
4. Attach a rear support bracket to the rear of the new radio and adjust as necessary to attach to the rear support stud located on the back of the pocket using the small phillips screw supplied with kit (optional).
5. Insert kit and radio into dash. Line up with the factory mounting point. Secure to the dash using the factory 7mm bolts.

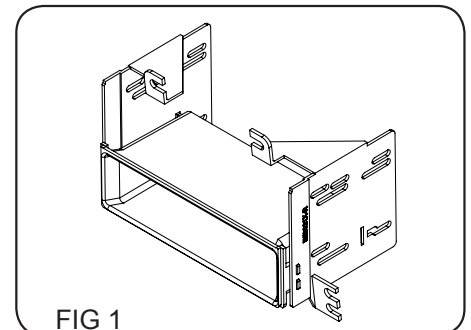

Kit Assembly Instructions (Double DIN)

Double DIN Mount Applications

1. Remove the Shaded tab from the back edge of each left and right mounting bracket (right side not shown). FIG 2
2. Attach the left and right side brackets to an ISO mountable radio using screws provided with radio when possible or hardware included with kit. FIG 3
3. Insert kit and radio into dash. Line up with the factory mounting point. Secure to the dash using the factory 7mm bolts.

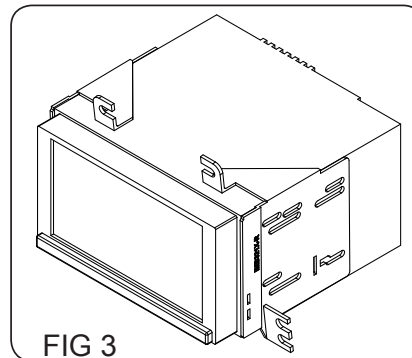
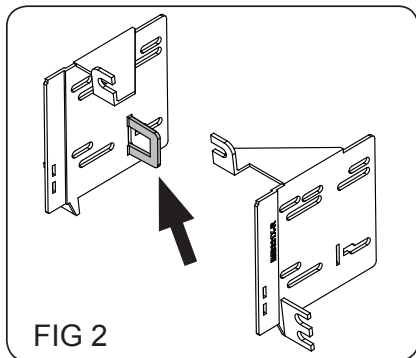

Installation of the PAC HVAC control panel

Vehicles equipped with Non-MyLink radios

1. Connect the RPK5-GM4101-KIT-HAR to the vehicles white 20 pin connector that was originally connected to the factory HVAC control panel.
2. Connect the 8 pin Black Micro-fit Molex connector to the circuit board mounted to the back side of the PAC HVAC control module.
3. Tape up or remove the loose Orange / Black and Pink / Black wires as they are only needed for applications where the vehicle was factory equipped with the touchscreen MyLink radio.
4. Fit the PAC HVAC control panel into the vehicle opening and secure at the bottom using the factory mounting hardware.
5. Assemble the remaining pieces of the dash.

Installation of the PAC HVAC control panel (cont.)

Vehicles equipped with MyLink radio

1. Connect the RPK5-GM4101-KIT-HAR to the vehicles white 20 pin connector that was originally connected to the factory HVAC control panel.
2. Connect the 8 pin Black Micro-fit Molex connector to the circuit board mounted to the back side of the PAC HVAC control module.
3. Locate the Orange/Black (Pin 15) and Pink/Black (Pin 19) wires in the 27 Pin Lt. Blue connector at the Body Control Module (BCM). The BCM is located under the driver side of the dash.
4. Connect the loose end of the Orange / Black extension wire to the Orange/Black wire in Pin 15.
5. Connect the loose end of the Pink / Black extension wire to the Pink/Black wire in Pin 19.
6. Route both of the extension wires to the right and through the same opening that the White 20 pin connector passes through and connect them to the bullet connectors on the RPK5-GM4101-HIT-HAR. Be sure to not route these wires near any moving parts as it could cause damage to these wires in the event they become pinched.
**** If the kit mounted door lock buttons operate in reverse after connection of these wires, then the Orange / Black wire and Pink / Black have been connected in reverse. To fix, reverse the connections at the wires or simply swap the wires at the bullet connectors****
7. Fit the PAC HVAC control panel into the vehicle opening and secure at the bottom using the factory mounting hardware.
8. Assemble the remaining pieces of the dash.

Picture of the BCM which is located under the driver side of the dash just above the steering column

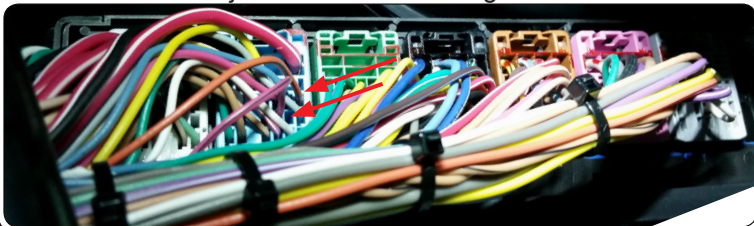

Close up of the Light Blue connector located at the BCM

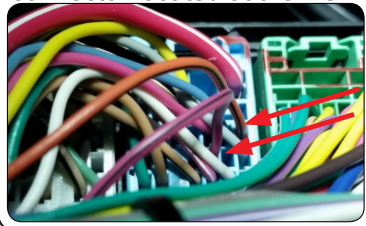

PAC HVAC Control Panel Testing and Verification

1. Turn the ignition on. The LCD at the top of the kit should come on and display the temperature.
2. Verify functionality of the lock, unlock and hazard buttons.
3. Verify functionality of the rotary dials and all of the push buttons on each of HVAC knobs.
4. For double DIN applications equipped with a 7" screen, verify that the face of the radio does not come in contact with the kit when ejecting a disk. If it does you will need to adjust placement of the double DIN radio in the mounting brackets.
5. Verify the LED backlights dim when using the factory dimmer control.
6. Verify that the kit, including the temperature LCD, shuts off when the key is turned to the off position.

Temperature Display Settings and Operation

The temperature display is a multifunction display which will display the temperature, the firmware version number and allow you to change between the preloaded splash screen options.

Switching between Fahrenheit and Celsius:

Press and hold the A/C (snowflake) button for 5 seconds to switch the temperature display at the top of the kit between Celsius and Fahrenheit. Pressing and holding the A/C (snowflake) button again for 5 seconds will switch it back. The Kit will default to Fahrenheit upon first power up or upon a power cycle (remove and apply power to kit).

Displaying the Firmware Version of the PAC HVAC Control Panel:

Press and hold the recirculation button for 5 seconds to display the firmware version of the PAC HVAC control panel.

Changing the Splash Screen:

Press and hold the rear defrost button for 5 seconds to change the splash screen that is shown when the kit powers up. Each time the button is pressed and held for 5 seconds it will advance to the next splash screen. Once the splash screen has changed you will need to release the button and press and hold it for 5 seconds for it to change again. For the order in which the splash screens will change when the button is held, see below:

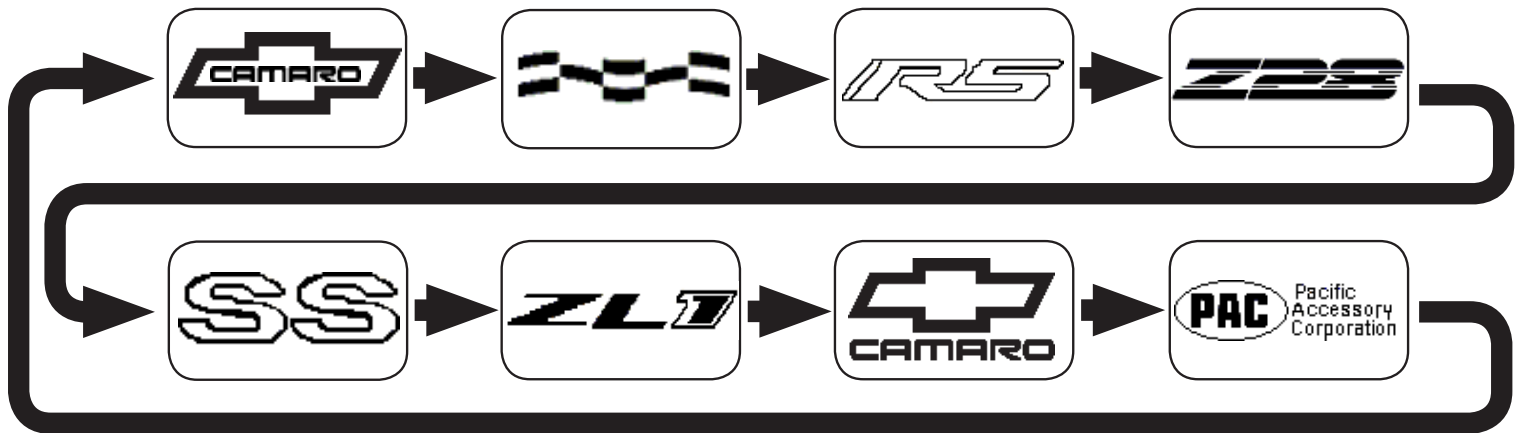

Issue:

Upon turning on the ignition, the HVAC controls and backlighting in the RPK-GM4101 dash kit are inoperable.

Solution:

The HVAC board in the RPK-GM4101 needs to be updated with the latest firmware.

Important Notes:

- Please note that you are going to update the firmware on the HVAC board in the dash kit, ***NOT*** the RP5 interface.
- You must follow the instructions/procedures outlined in this tech brief. Do not follow the instructions found on the firmware updater page. Those are strictly for updating the RP5 interface.

Update Procedure:

1. Create a new folder on your PC desktop titled RPK5-GM4101 Firmware.
2. Go to **pac-audio**, and select the RPK5-GM4101 from the drop down menu.
3. Now, scroll to the bottom of the page, and download the Firmware Version 6, and the Utility/Other Version 11 (Fig. A). Save these files in the folder you created in step 1. This will make the process much easier as everything will be located in one folder .

Fig. A

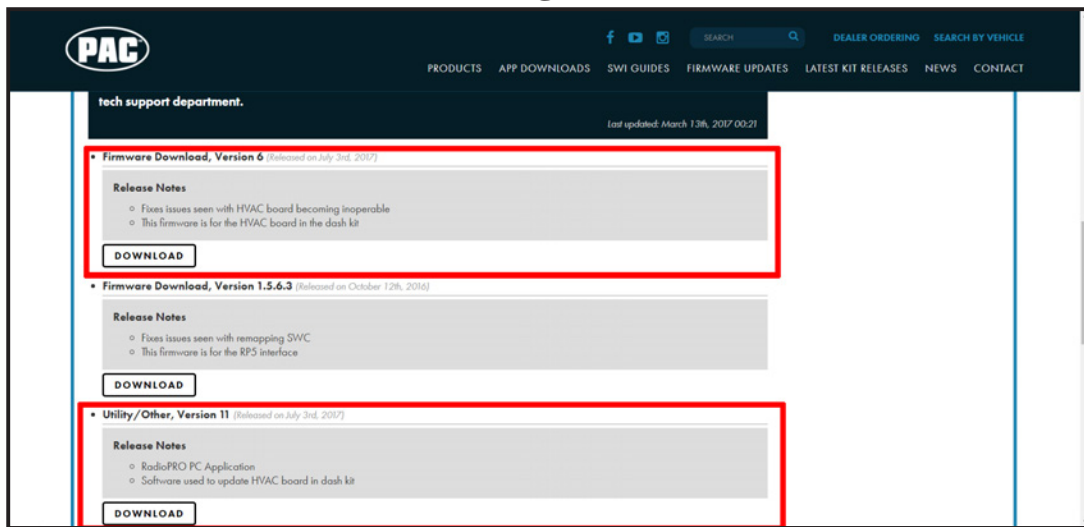

4. Once you have downloaded both files, go to the folder you created in step 1.
5. Right click on each file and choose "Extract All" (Fig. B), then "Extract". This should create two new folders with the same names as the zip folders (Fig. C)

Fig. B

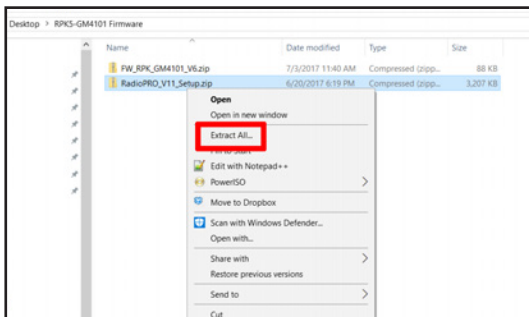
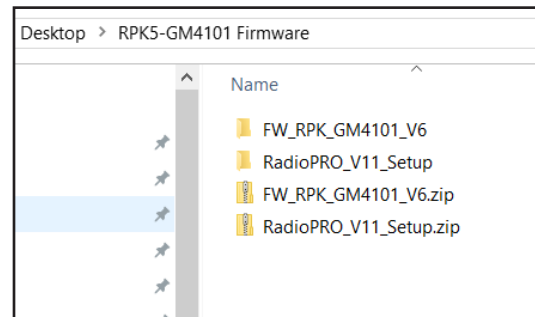

Fig. C



6. Open up the folder titled “RadioPRO_V11_Setup”, and install the RadioPRO application onto your PC.
7. Once you have installed the RadioPRO application, launch it by double clicking the new RadioPRO icon on your desktop.
8. Now, select “Support” (Fig. D), then “Device Recovery” (Fig. E), then “Enable Recovery” (Fig. E PLEASE NOTE: Once you click “Enable Recovery”, the dialogue box will switch to “Disable Recovery”).

Fig. D

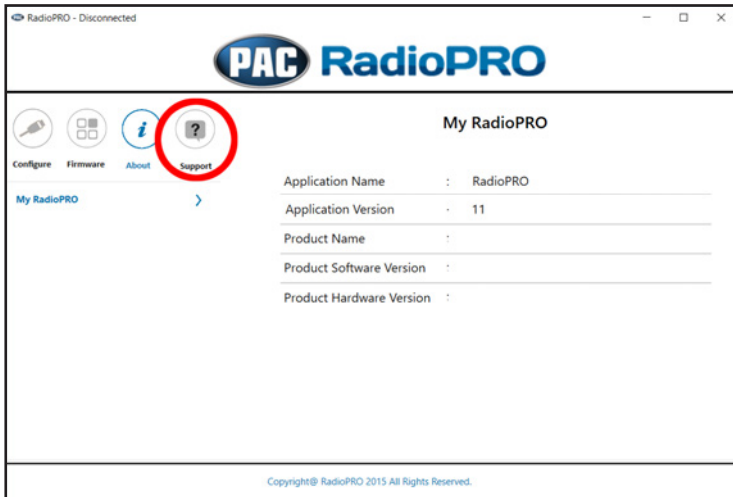

Fig. E



9. Now you can connect the HVAC board to the PC via the micro USB connector found on the top right corner of the board, just below the LCD screen harness connector. (Fig. F).
10. Once connected, the app should switch back to the “About” screen, and look like Fig. G. **This may take up to 10 seconds while the board initializes.**

Fig. F

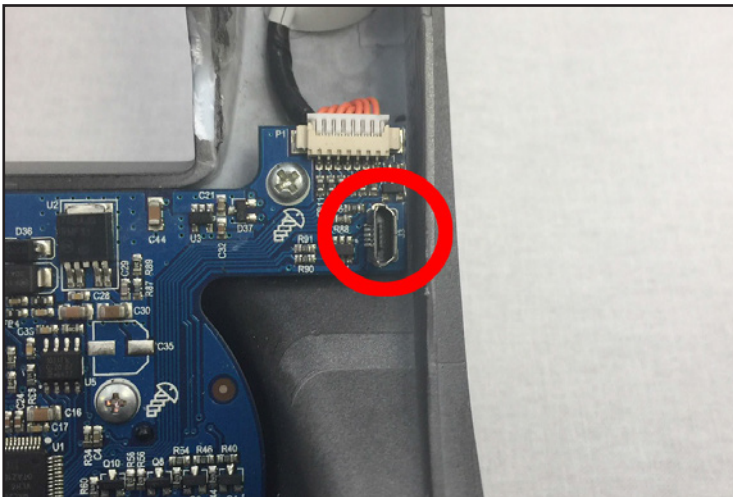

Fig. G



11. Next, select “Firmware” (Fig. H), then select “Select File” (Fig. I).

Fig. H



Fig. I



12. Now browse to the firmware file titled “FW_RPK_GM4101_V6.pufx” (Fig. J). This will be in the folder you created on your desktop back in step 1.

13. Double click the file to select it and you will see a window that looks like Fig. K. Select “Yes”.

Fig. J

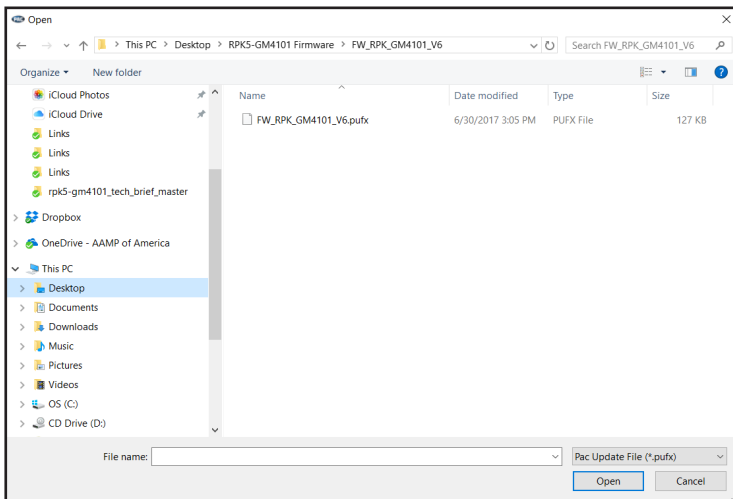
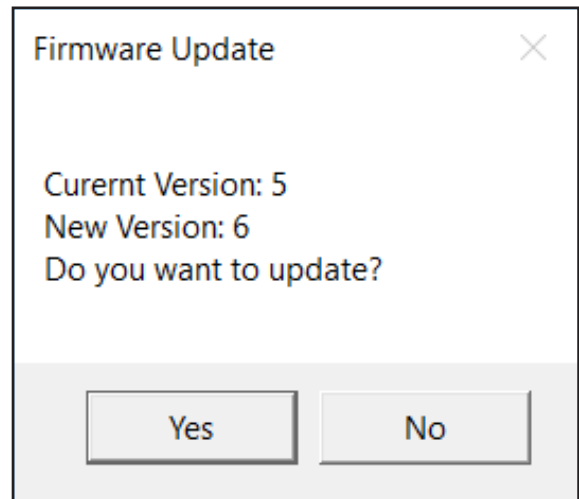

Fig. K



14. Once you select "Yes" in step 13, the update process will begin. You will see a progress bar like in Fig. L.
15. Once the update is complete you will get the message in Fig. M. Select "OK".
16. You may now disconnect the RPK-GM4101 from the PC and re-install into the vehicle.

Fig. L

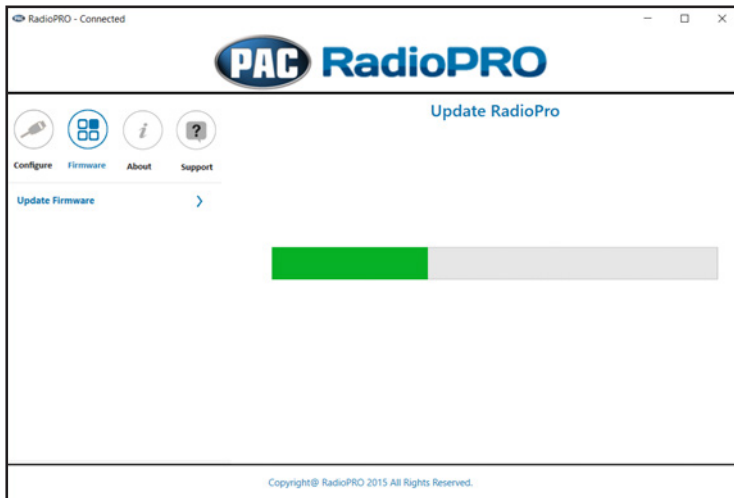
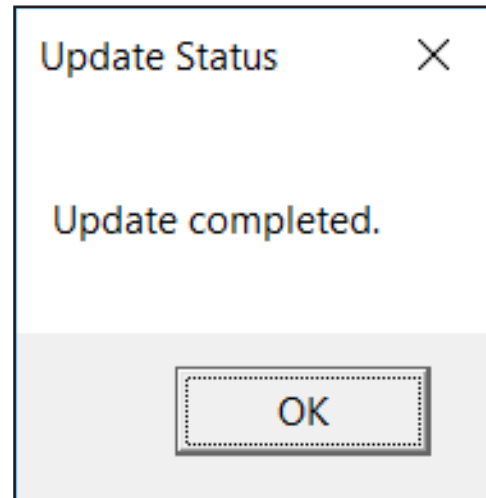

Fig. M



Overview

Symptom: The 12v+ accessory output drops out at high volume causing the aftermarket radio to shut down.

Cause: Aftermarket radios with high powered speaker outputs, played at high volumes, cause the interface's components to overheat, thus resulting in the 12v accessory output failure.

Solution: Wire 3 of the 4 factory speakers directly to the outputs of the aftermarket radio, bypassing the interface. You will need to leave the front left speaker wired through the interface in order to retain the OnStar functionality.

Disconnect the Speaker Wires

The RadioPRO5 Module has 2 harnesses:

- a. RP5-Radio harness (RP5-RADPWRAUDIO)
- b. Vehicle harness (OS-GMLAN29)

1. Disconnect speaker wires from the Aftermarket Radio harness

- a. Cut the positive and negative speaker wires for the Left Rear, Right Rear and Right Front channels, away from the RP5-Radio harness.
- b. NOTE: The Left Front speaker wires must remain connected for OnStar audio.

2. Modify the Vehicle harness

- a. Cut the positive and negative speaker wires for the Left Rear, Right Rear and Right Front channels, away from the RP5 module.
- b. NOTE: The Left Front speaker wires must remain connected for OnStar audio.

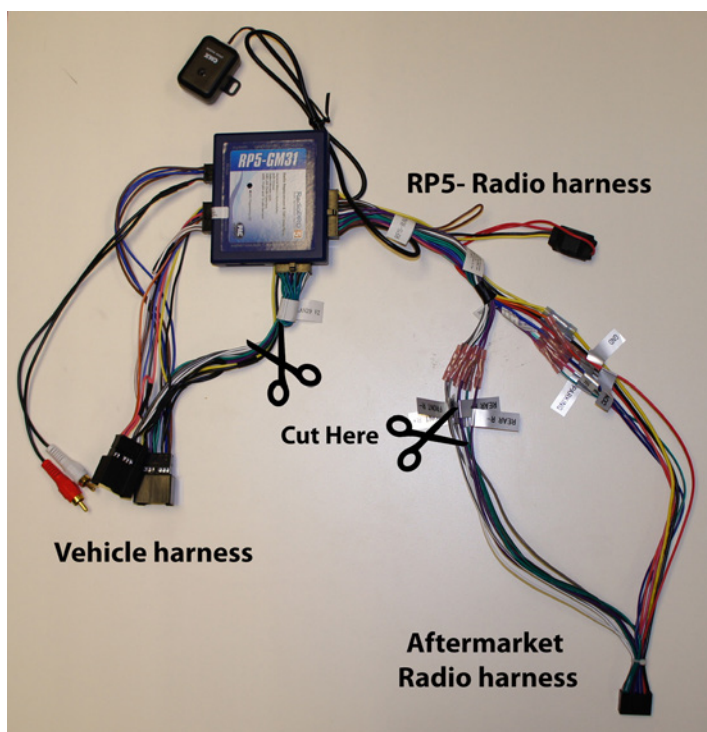

Reconnect the Speaker Wires

1. Connect the 3 channels of speaker wires from the Aftermarket Radio harness to the speaker wires on the Vehicle harness, bypassing the RP5 module, as shown below.

