

Introduction & Features

The RP4-HD11 interface allows the replacement of a factory radio in select Honda vehicles with MSCAN databus radios. Using this interface will retain factory features such as steering wheel controls (SWC), the factory amplifier and the ability to set the factory clock when the original radio is removed. Use of this interface also allows you to program two radio functions to each SWC button by using short press long press dual command functionality. The RP4-HD11 also provides data bus driven outputs such as accessory power, vehicle speed sensor (VSS), illumination, reverse trigger and parking brake.

Important Notes

1. The radio select rotary switch on the side of the interface must be adjusted to the proper radio setting before plugging the interface into the vehicle (see next page for setting chart).
2. The interface comes pre-programmed for all of the vehicles factory SWC functions and does not require programming unless you wish to re-assign the SWC functions or utilize short press long press dual command functionality. The SWC can always be restored to default settings by pressing and releasing the program button on the side of the interface once and waiting 7 seconds for the LED to flash 4 times.
3. Vehicles equipped with factory navigation must follow the installation tech brief.
4. **Vehicles equipped with a 7" touchscreen:** Once the factory head unit has been removed you will no longer be able to set the clock or date on the factory display as this is derived from the factory head unit. The date on the screen can be permanently removed by disconnecting the battery to clear the screen's memory. In order to set the clock you will need to disconnect the vehicles battery at 1:00 as this is the time the screen defaults to once it has been reset.
5. The LED will flash whenever a SWC button is pressed.

Wiring Connection Chart

Interface Connector		Vehicle Connector		SWC Connector	
Red / White	Parking Brake Output (-)	Yellow	Battery +12v	Blu/Yel	Kenwood, Newer JVC
Purple / White	Vehicle Speed Output	Black	Ground	3.5mm Jack	Alpine, JVC, Clarion, Fusion, Pioneer, Sony, Boyo, Dual, Lightning Audio, Visteon or Advent
Red	Accessory Output (1 amp)	Orange	Dimmer		
Orange / White	Illumination Output (+)	Orange/White	Illumination		
Green	Reverse Output (+)	White	Front L + input		
White/Green	SWC Analog Input	White / Black	Front L - input		
		Grey	Front R + input		
		Grey / Black	Front R - input		
		Green	Rear L + input		
		Green / Black	Rear L - input		
		Purple	Rear R + input		
		Purple / Black	Rear R - input		

Illustration / Schematic

Wiring

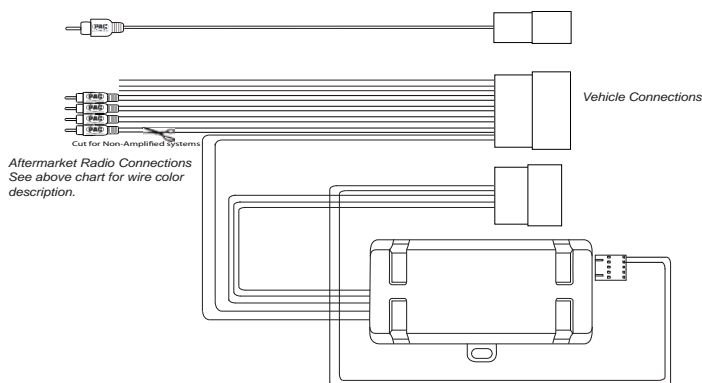

SWC Connection

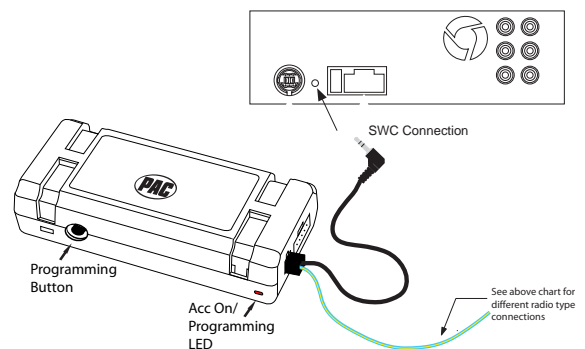

Installation Steps

SET RADIO SELECT SWITCH



Alpine	JVC	Kenwood	Clarion	Pioneer/Other	Sony	Fusion
1	2	3	4	7	8	9

Other = Advent, BOYO, Dual, Lightning Audio, Rockford Fosgate, Visteon

IMPORTANT! If you wish to use the Voice, Answer and End buttons you must hardwire them into the RP4-HD11. The wire you need to connect into can be found by removing the plastic panels surrounding the steering wheel column and accessing the connector which houses the wire (Fig. 1). Once you have located the connector you must connect into the wire located in pin 3 (Fig. 2). Wire colors are normally Blue in the Civic & Yellow in the CRV but may vary by vehicle. Connect to the RP4-HD11 interface connector as shown in Fig. 3.

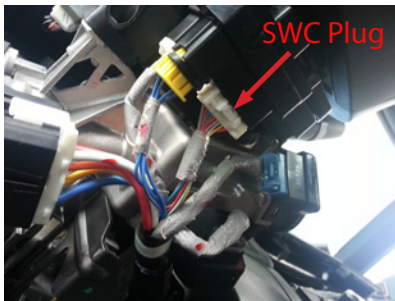

Fig. 1

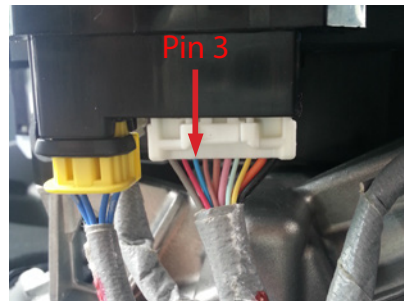

Fig. 2

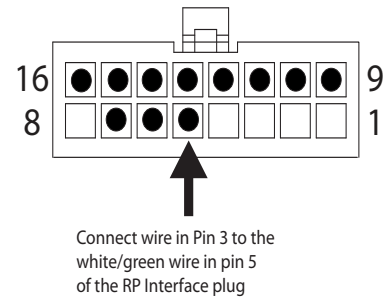

Fig. 3

1. The radio select rotary switch on the side of the interface must be adjusted to the proper radio setting before plugging the interface into the vehicle.
2. Make all connections as described in the chart on page 1. **If there is a Premium Audio system present:** Connect the RCA inputs to the aftermarket radios pre-amp output. The audio level will vary depending on the new radios pre-amp output voltage (2-4 volts is recommended). **If there is not a Premium Audio system present:** Cut the RCA inputs off and connect the aftermarket radios speaker outputs to the remaining wire according to the chart on page 1.
3. If the vehicle is equipped with a factory subwoofer plug the RCA cables connected to the 8 pin plug into the Subwoofer or Non-Fading output of the aftermarket radio.
4. Connect the SWC wire according to the chart on page 1 (aftermarket radio MUST support a wired remote input).
5. If you wish to reassign functions to the SWC follow the programming instructions on the next page.

Default Steering Wheel Control Programming

IMPORTANT! The interface comes pre-programmed for all of the vehicles factory SWC functions and does not require programming unless you wish to re-assign the SWC functions or utilize short press long press dual command functionality. The SWC can always be restored to default settings by pressing and releasing the program button on the side of the interface once and waiting 7 seconds for the LED to flash 4 times.

Default SWC Button Assignments

	Alpine	JVC	Kenwood	Clarion	Pioneer	Sony	Fusion
Volume +	Volume +	Volume +	Volume +	Volume +	Volume +	Volume +	Volume +
Volume -	Volume -	Volume -	Volume -	Volume -	Volume -	Volume -	Volume -
Source	Source	Source	Source	Source	Source	Source	Source
Track +	Track +	Track +	Track +	Search +	Track +	Track +	Track +
Track -	Track -	Track -	Track -	Search -	Track -	Track -	Track -
Voice/Mute	Mute	Mute	Mute	Mute	Mute	Mute	Mute
Phone Answer	Receive	Receive	Answer	Send	Answer Call	Answer/End	Audio
Phone End	End	Reject	Voice	End	End	Reject/Source	Power

Optional Steering Wheel Control Programming

If you wish to re-assign the SWC functions or utilize short press long press dual command functionality, the interface must be programmed in the specific order shown on the chart below. If you come across a function in the chart that your steering wheel does not have, or you do not want to program, press and release the program button on the side of the interface to skip that function. The LED will flash off and on confirming that you have successfully skipped that function and are ready to proceed to the next one.

SET RADIO SELECT SWITCH



Alpine	JVC	Kenwood	Clarion	Pioneer/Other	Sony	Fusion
1	2	3	4	7	8	9

Other = Advent, BOYO, Dual, Lightning Audio, Rockford Fosgate, Visteon

PLEASE NOTE: The screen on the dash can not be in the “Vehicle Menu” mode when reprogramming the SWC. If the screen displays “Vehicle Menu”, press the Menu button on the SWC to leave this screen and ensure you are in the proper mode before proceeding.

- Turn the key to the ignition position.
- Press and release programming button on the side of the interface.
- Within 7 seconds, press the button that is to be learned on the steering wheel. The LED will turn off when the button is pressed.
 - At this point you have two options:**
 - A. For short press functionality:** Release the button within 1.5 seconds. The LED will turn back on.
 - B. For long press functionality:** Hold the button until the LED starts blinking. Release the button and the LED will go back to solid.
- If you need to program more buttons, repeat step 3 for each additional audio function on the steering wheel.
- If you come across a function in the chart that your steering wheel does not have, or you do not want to program, press and release the program button on the side of the interface to skip that function.
- Once programming is completed, wait seven seconds. The LED will flash three times indicating end of programming.
- Test the interface for proper functionality. Whenever a SWC is pressed the LED on the interface should blink. If any function does not work, repeat the programming steps

Optional Programming Order

	Alpine	JVC	Kenwood	Clarion	Other*	Pioneer	Sony	Fusion
1	Volume +	Volume +	Volume +	Volume +	Volume +	Volume +	Volume +	Volume +
2	Volume -	Volume -	Volume -	Volume -	Volume -	Volume -	Volume -	Volume -
3	Mute	Mute	Mute	Mute	Mute	Mute	Mute	Mute
4	Preset +	Source	Source	Source	Preset +	Preset +	Preset +	Source
5	Preset -	Track +	Play	Search +	Preset -	Preset -	Preset -	Track +
6	Source	Track -	Track +	Search -	Source	Source	Source	Track -
7	Track +	Band/Disc +	Track -	Band	Track +	Track +	Track +	Audio
8	Track -	Preset/Disc -	Disc/FM +	Send/End	Track -	Track -	Track -	Power
9	Power	Select	Disc/AM -	Send	Band	Band	Band	
10	Enter/Play	Attenuation	Answer	End	N/A	Phone Menu	Reject Call/Source (Bluetooth equipped radios only)	
11	Band/Program	Phone Receive	Voice Dial			Answer Call	Answer/End Call	
12	Receive	Phone Reject	On Hook			End Call		
13	End	Voice Dial	Off Hook			VR		
14	VR	Power	Mute (Multimedia units only)					
15			Preset +					

*Other = Advent, Boyo, Dual, Lightning Audio, Rockford Fosgate, & Visteon

SWC Re-calibration

This section only applies to the Answer, Hang Up and Voice buttons. All of the other buttons are data driven and will never require recalibration.

SWC re-calibration is necessary when the SWC operation is erratic or non-existent. This process re-calibrates the SWC values to the RP4 interface so it will know what they can be set to for button function assignment. The interface must be programmed in the specific order shown in the chart below. If you come across a function in the chart that your steering wheel does not have you must press and release the program button on the side of the interface to skip that function. The LED will flash off and on confirming that you have successfully skipped that function and are ready to proceed to the next one.

The SWC and radio command assignments can always be restored to default values by entering re-calibration mode (Steps 1-2) and not pressing any buttons. After 7 seconds the re-calibration mode will time out and all default values will be restored.

1. Turn the key to the ignition position.
2. Press and hold the programming button for 7 seconds until the LED begins blinking. When the LED begins blinking, release the programming button.
3. Within 7 seconds, press and release the button that is to be learned on the steering wheel. The LED will turn off when the button is pressed and come back on when it is released.
4. If you need to program more buttons, repeat step 3 for each additional audio function on the steering wheel.
5. If you come across a function in the chart that your steering wheel does not have, press and release the program button on the side of the interface to skip that function.
6. Once programming is completed, wait seven seconds. The LED will flash three times indicating end of programming.
7. Test the interface for proper functionality. Whenever a SWC is pressed the LED on the interface should blink. If any function does not work, repeat the programming steps

Answer
Hang Up
Voice

After you have re-calibrated the SWC buttons, the default SWC button assignments will be the same as what is listed in the chart on page 3. If you wish to re-assign button functions you must also go through the programming process on page 4.

Product Updates (Firmware)

The RP4-HD11 can be updated with new firmware as it becomes available using the PAC-UP interface updater (sold separately).

Follow the procedure listed below to update the RP4-HD11:

1. Unplug all connectors from the RP4 interface
2. Set the rotary switch to position 0
3. Connect the PAC-UP
4. Update the interface
5. Disconnect the PAC-UP
6. Set the rotary switch back to normal operating position
7. Re-connect the RP4 to the vehicle

Overview

When installing the RP4-HD11 into 2012-2016 vehicles with factory navigation, it will be necessary to make hardwired connections. This is necessary due to models equipped with navigation having a different plug in which the MS-CAN, Subwoofer, and Reverse Camera wires are located. Please follow the procedure outlined below to make the proper connections.

Important Notes

1. This tech bulletin only needs to be followed when installing the RP4-HD11 into vehicles equipped with a factory navigation head unit. Vehicles equipped with a non-navigation head unit should refer to the instruction manual included with the interface.
2. It is important that all connections be soldered to ensure they are secure. Using T-Taps or crimp connectors may result in faulty connections which could cause erratic/unreliable operation.
3. Once the factory head unit has been removed you will no longer be able to set the clock or date on the factory display, as this is derived from the navigation head unit's GPS signal. The date on the screen can be permanently removed by disconnecting the battery to clear the screen's memory. In order to set the clock you will need to disconnect and reconnect the vehicle's battery at 1:00 as this is the time the screen defaults to once it has been reset.

Installation Steps

1. Connect the main 24-pin harness and the analog SWC wire as outlined in the instruction manual included with the interface.
2. Locate the pink and pink/black MS-CAN data wires in the 20-pin RP4-HD11 harness (Fig. 1). These wires will need to be jumped to the pink and blue data wires located in pins 1 and 9 of the 16-pin vehicle connector (Fig 2).
3. Locate the subwoofer wires in pins 3 and 11 of the 16-pin vehicle connector (Fig. 3). In the Civic pin 3 is pink and pin 11 is blue. In the CRV pin 3 is green and pin 11 is purple. You will need to connect an RCA cable to these wires and connect it to the subwoofer output of the aftermarket radio.
4. For reverse camera retention you must power up the factory reverse camera and connect a composite video cable to the 7-pin vehicle connector (Fig. 4, wire colors may vary by vehicle). pin 3 is video signal + and pin 6 is video signal -. pin 4 is camera power - and pin 7 is camera power +.

Illustration / Schematic

RP4-HD11
Connector

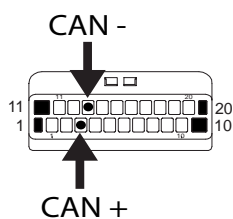

Fig. 1

16-Pin Vehicle
Connector

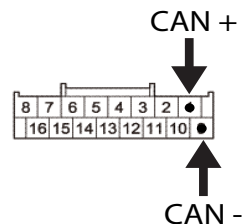
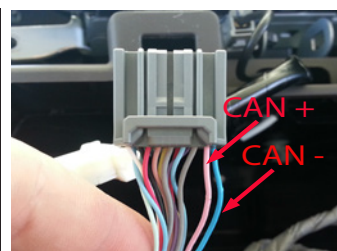

Fig. 2

16-Pin Vehicle
Connector

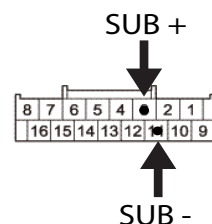
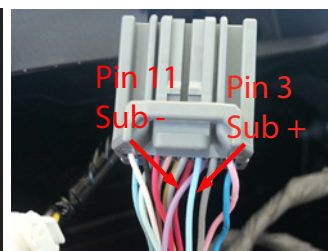

Fig. 3

7-Pin Vehicle
Connector

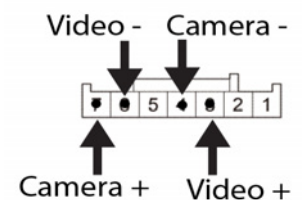
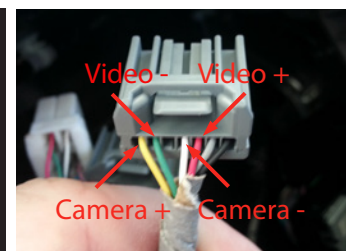

Fig. 4

All connectors are viewed from wire side

