



# C2R-GM11b

## GM Radio Replacement Interface for GMLAN 11-bit Vehicles Without OnStar®



This Interface is Intended for use in Vehicles without OnStar® or when OnStar® is not serviced or is unwanted. For OnStar® Retention use the OS-311b.

The C2R-GM11b allows aftermarket radio installation without retention of the factory radio. The interface replicates all factory warning chimes, audible turn signal indicators and provides a data bus generated 12 volt accessory output that acts just as GM's R.A.P. (Retained Accessory Power) system did prior to radio removal. R.A.P. keeps the radio powered after the key is off, until the driver door is opened or a 10 minute timer ends, whichever comes first. The C2R-GM11b will work with or without factory amplified audio systems.

### Installation:

Connect the speaker level radio outputs to C2R-GM11b's speaker inputs. If the vehicle and the interface both chime, move the chime switch to the off position. The other wire connections are as follows:

- Yellow - 12 Volt Constant Voltage
- Black - Ground
- Red - 12 Volt R.A.P Voltage (1 AMP max)
- Blue/White - Antenna turn on, Amplifier turn on
- Orange - Dimmer/Illumination
- Lt. Green - SWC Output Wire

**Using the SWC Output wire** - Connect the SWC (green) output wire to a P.A.C. SWI interface. Use the green SWI interface wire and program the SWI interface for version 1. Do not cut the Brown loop.

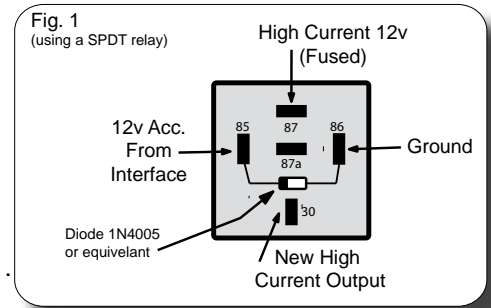

\*\*If more than 1 AMP is needed from the Red +12v Accessory wire refer to Fig 1.

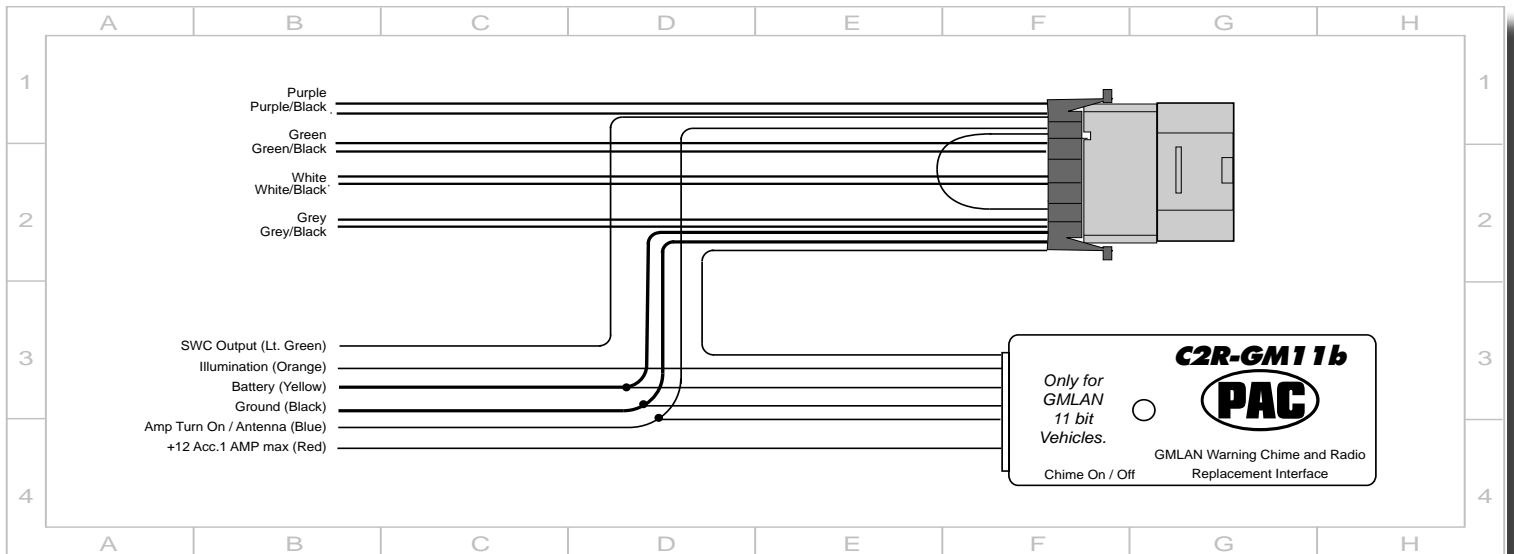

**DISCLAIMER:** Under no circumstances shall the manufacturer or the distributors of the C2R-GM11b parts be held liable for consequential damages sustained in connection with the C2R-GM11b. The manufacture and it's distributors will not, nor will they authorize any representative or any other individual to assume obligation or liability in relation to the C2R-GM11b other than its replacement.



**Pacific Accessory Corporation** 2009 Pontiac G6 - GM changed the radio halfway through the year so there are two harness possibilities in this vehicle. If the radio in the vehicle looks like the first picture you are good to use the C2R-GM11b. However if the radio in the vehicle looks like the second picture you will need to use C2R-GM11.

