

PROBLEM: In some cases, Ford amplified systems may cause feedback to the C2R-FRD1 module and cause the radio to turn off intermittently or restart especially at higher volumes.

FIX: Cut the White/Green wire coming from the C2R-FRD1 module and solder a 1 amp diode (Radio Shack part no. 1N4005) or equivalent, inline on the white/green wire as shown in the diagram below. Make sure that the diode's stripe is towards the harness of of the C2R module.

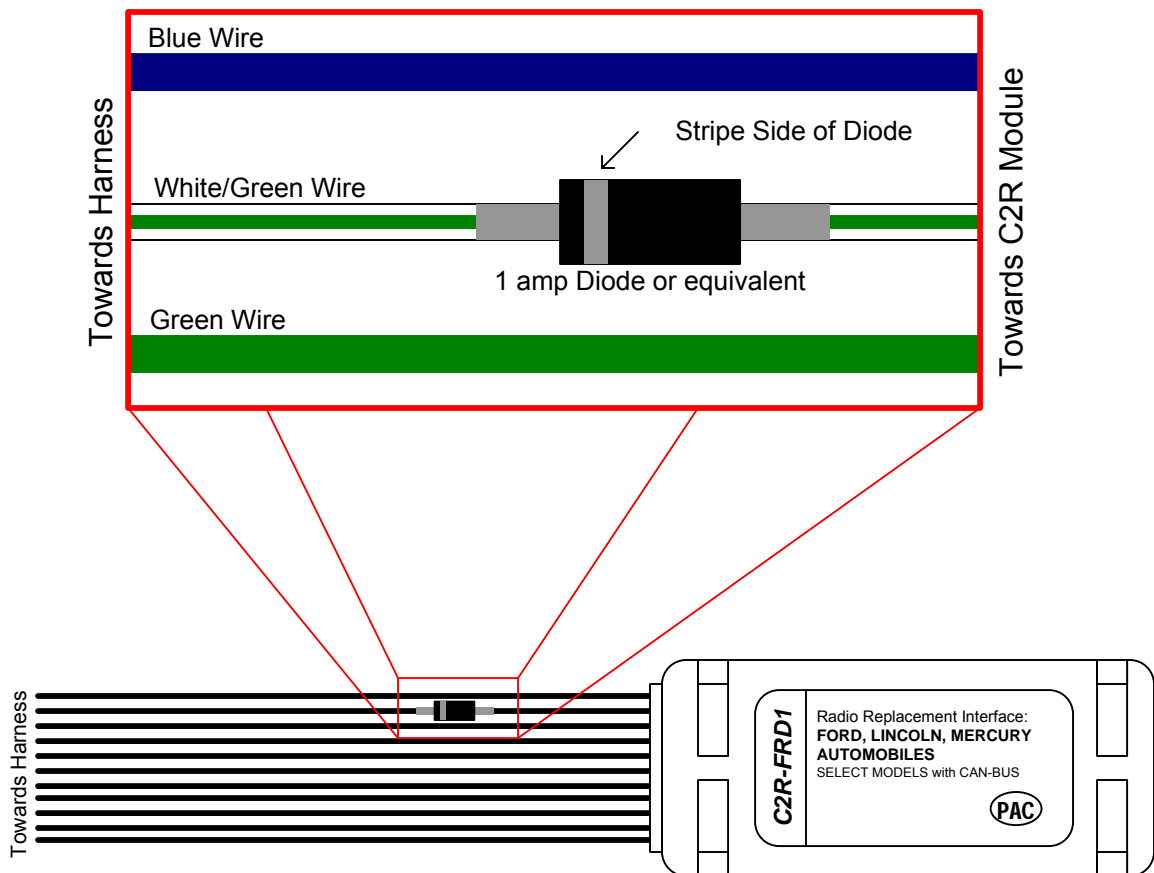

C2R-FRD1 Tech Brief

Fix For:
"No Audio when using the C2R-FRD1"



Problem:

When using the C2R-FRD1 in 2009 Ford / Lincoln / Mercury vehicles with an amplified system, other than Sony or THX, audio is not present. This is due to the turn-on lead being located in a different position.

Solution:

Follow these steps to turn the factory amplifier on:

1. Locate the 24 pin main power harness in the vehicle.
2. Locate the Yellow/Purple wire in pin 7 of the main power harness in the vehicle.
3. Connect a jumper wire from the Yellow/Purple wire in the vehicle harness to the White/Green wire which connects from the C2R-FRD1 module to the 8 pin sub connector.

Connectors are viewed from wire side

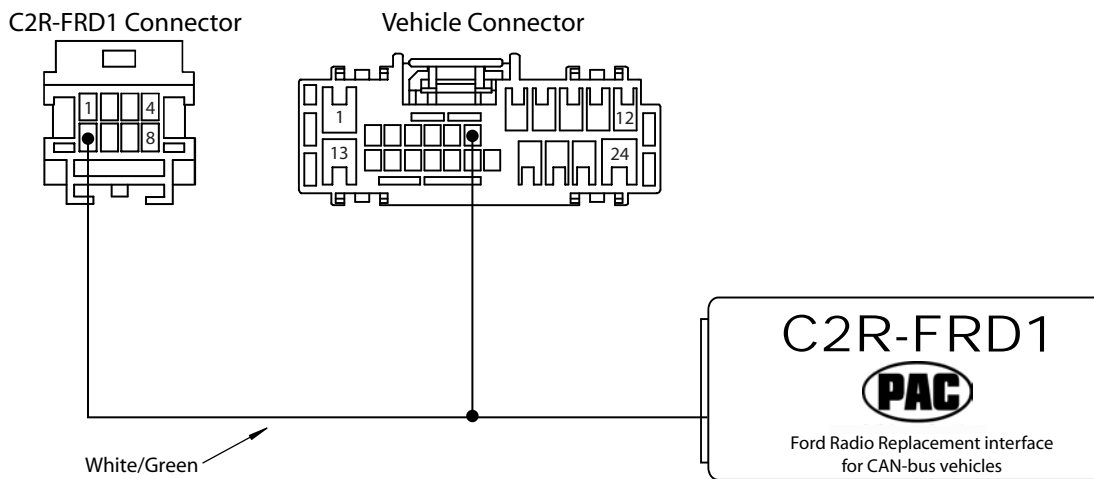



Pacific Accessory Corporation

C2R-FRD1

Radio Replacement Interface for Select 2005+ MSCAN Ford / Lincoln / Mercury Vehicles

The C2R-FRD1 is an essential installation accessory for select 2005+ Ford/Lincoln/Mercury vehicles with MSCAN databus radios. Using this interface will enable factory features such as rear seat entertainment (RSE), rear seat controls (RSC) and the THXII amplifier when the original radio is removed. Other features of the C2R-FRD1 include data bus driven retained accessory power (RAP), vehicle speed sensor (VSS) output, illumination, reverse output, parking brake output and a 5 volt regulated amp turn on for factory installed subwoofers.

Installation:

1. Make radio necessary connections to the provided harness, independently isolating unused wires. The wire colors and descriptions are noted aside. The RAP output will last for approximately 10 minutes after the key is off or until a door is opened. This output is rated at 1 amp max (for more current refer to figure 1).
2. The steering wheel control (SWC) output wire can only be connected to an optional SWC interface (SWI-xxx sold separately). Use the vehicle specific interface version number, additional connection notes and programming information provided with the SWC interface.
3. The ability to fade the THXII amplifier is lost once the factory radio is removed. The amplifiers DSP mode is set for "all seats" by the C2R-FRD1 interface.
4. The AUX Jack RCA cables come from the original 3.5mm auxiliary connection if equipped. This can be connected to the radios auxiliary input to make use of the existing auxiliary connection location.
5. The RSE/RSC RCA cables come from either the overhead DVD system or the rear seat controls if the vehicle is equipped. Connecting these cables to an auxiliary input will allow the overhead DVD or the RSC auxiliary source to be heard throughout the cabin when selected. The Single/Dual Play button will loop through the available modes listed below.
6. Most Ford/Lincoln/Mercury factory subwoofer inputs are mono, wires may only be present for 1 RCA cable. Connect this to your radio's non-fading output (sub out) if available. The front or rear pre-amp output is suitable for this connection.

Operation:

1. Using the RSE system:

DVD Single Play: DVD audio is routed to the RSE RCA cables behind the radio and the DVD video is displayed on the overhead LCD (default mode, resets upon engine crank).

DVD Dual Play: DVD audio is routed to the rear headphones (wireless and hard wired) and the DVD video is displayed on the overhead LCD. The rear speakers are muted (THXII the subwoofer is also muted).

DVD/AUX Single Play: The auxiliary input is located on the overhead LCD DVD. Audio is routed to the RSE RCA cables behind the radio and the auxiliary video will be displayed on the overhead LCD.

DVD/AUX Dual Play: Auxiliary audio is routed to the rear headphones (wireless and hard wired) and the auxiliary video will be displayed on the overhead LCD. The rear speakers are muted (THXII the subwoofer is also muted).

*****NOTE: If the Audio from the RSE is distorted, a SNI-1 will be required. See reverse side for diagram.*****

2. Using the Rear Seat Controls (RSC): When active the display will read "AUX".

AUX Single Play: The Auxiliary input located on the rear seat controls is routed to the RSC RCA cables behind the radio (default mode, resets upon engine crank).

AUX Dual Play: Auxiliary audio is routed to the rear headphones. The rear speakers are muted (THXII the subwoofer is also muted).

DISCLAIMER: Under no circumstances shall the manufacturer or the distributors of the C2R-FRD1 parts be held liable for consequential damages sustained in connection with the C2R-FRD1. The manufacture and it's distributors will not, nor will they authorize any representative or any other individual to assume obligation or liability in relation to the C2R-FRD1 other than its replacement.

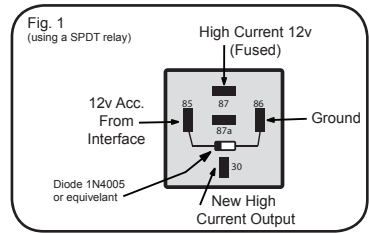
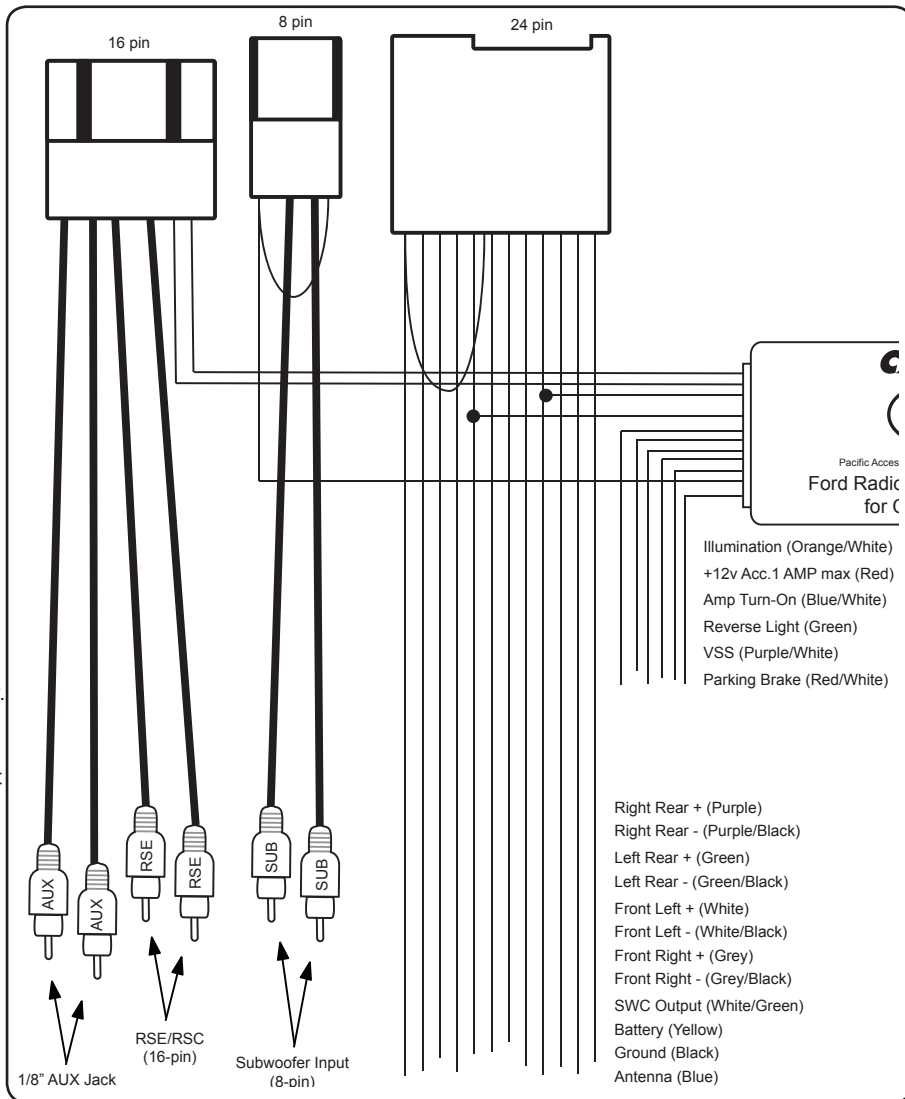



C2R-FRD1 Bulletin

Problem: Rear Seat Entertainment Audio Distortion



The audio signal coming from the RSE in Ford/Lincoln/Mercury vehicles is a differential output. Some auxiliary inputs on aftermarket radios have a common ground input that causes distortion in the RSE audio. The audio distortion can be fixed by using a ground loop isolator (PAC Part# SNI-1) between the RSE output from the C2R-FRD1 and the aftermarket radio's auxiliary input.

The SNI-1 is *directional* and will require additional RCA adaptors. (See diagram below)

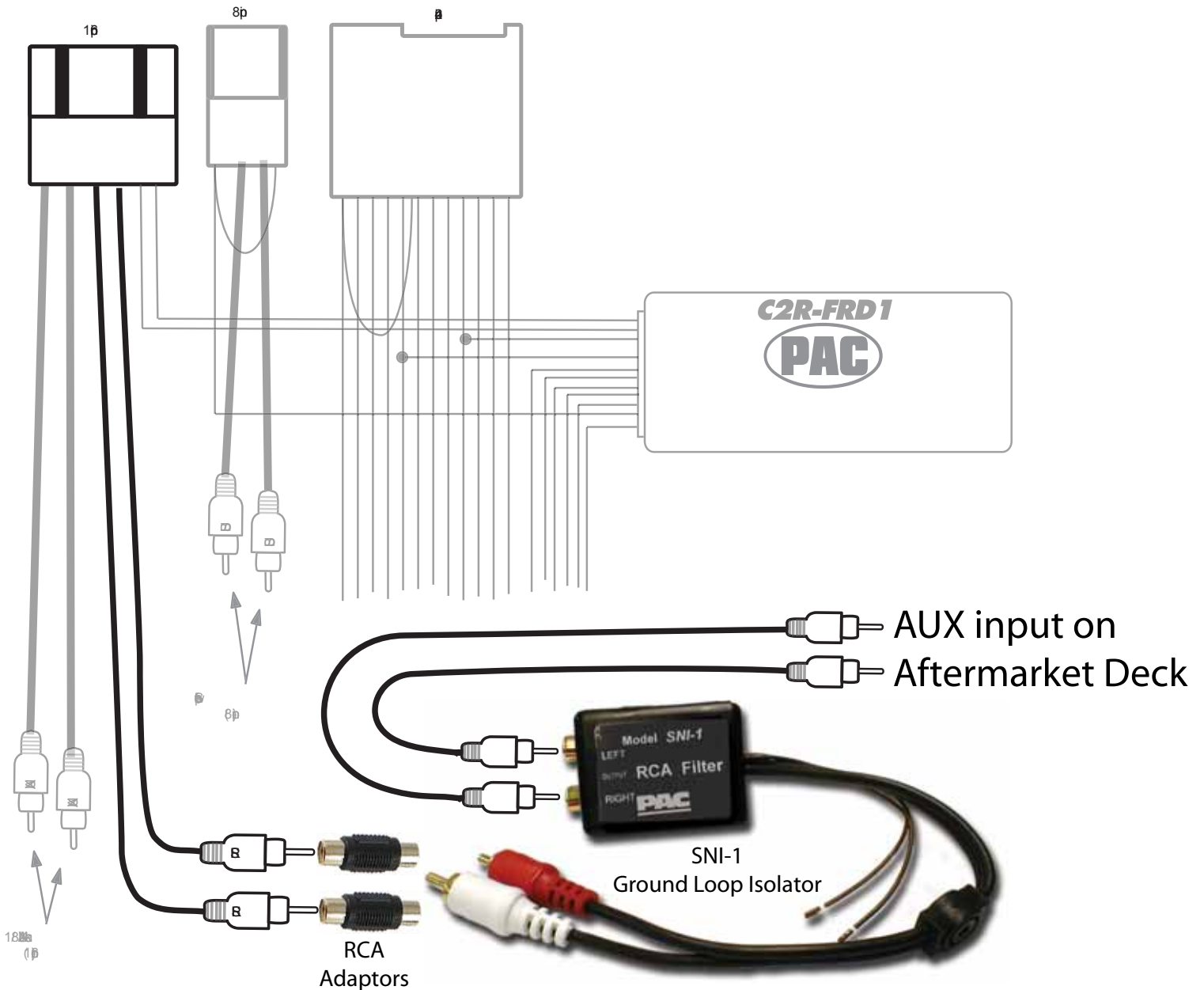

DISCLAIMER: Under no circumstances shall the manufacturer or the distributors of the C2R-FRD1 parts be held liable for consequential damages sustained in connection with the C2R-FRD1. The manufacture and it's distributors will not, nor will they authorize any representative or any other individual to assume obligation or liability in relation to the C2R-FRD1 other than its replacement.