

# OWENS 99-CURRENT FORD SUPER DUTY CREW CAB

YOUR BRACKETS INSTALL IN FACTORY HOLES

INSTALLATION PARTS LIST:	QTY.	DESCRIPTION	QTY.	DESCRIPTION
	1	RUNNING-BOARD 1 DRIVER & 1 PASSENGER	4	HORIZONTAL-BRACKET, SUPPORT, 3124F
	1	STONE GUARD 2 LEFT & 2 RIGHT	2	5/16" CLIP NUT
	8	3/8"x1 SELF TAPPING SCREW	20	5/16"x 3/4" BOLT
	8	#14x3/4" TEX SCREW	18	5/16-18 HEX NUT
	8	1/4"x5/8" SQUARE HEAD SCREW	4	FLAT BRACKET, FL11
	8	1/4-20 HEX NUT	1	END CAP 1 LEFT & 1 RIGHT

TOOLS REQUIRED: 5/16" DRILL • 1/2" HEX SOCKET • 1/2" WRENCH • 5/16" NUT DRIVER • 3/8" NUT DRIVER

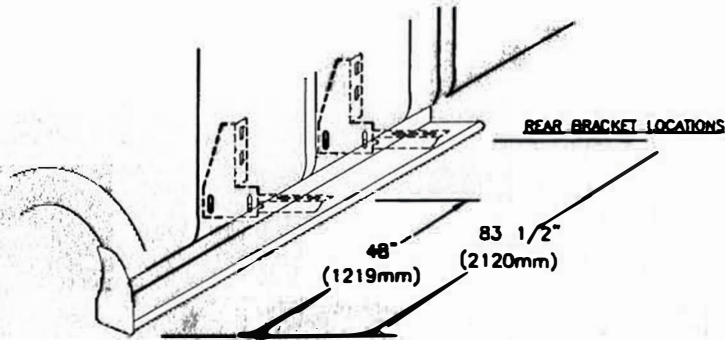

- ① (DRIVERS SIDE SHOWN)  
MEASURE FROM FRONT WHEEL WELL TO BRACKET LOCATION  
MARK THIS DIMENSION ON THE PINCH WELD

- ② BRACKET ASSEMBLY  
ASSEMBLE WITH 5/16" BOLTS

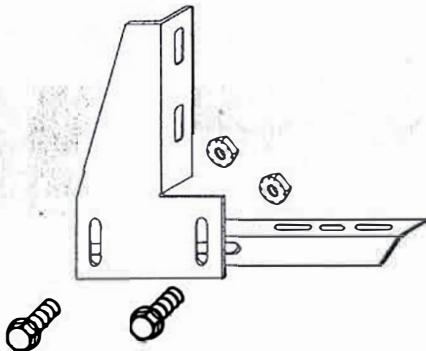

- SLIDE NUT CUP INTO BODY HOLES AT BRACKET LOCATION AT 48"

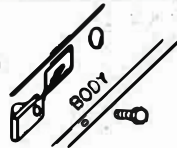

- ③ BRACKET ASSEMBLY MOUNT TO BODY @48" ASSEMBLE WITH 5/16" BOLTS AND NUT CUP AND 5/16" BOLT
- BRACKET ASSEMBLY MOUNT TO BODY @83 1/2" ASSEMBLE WITH 5/16" BOLTS AND #14 SELF DRILLING SCREW

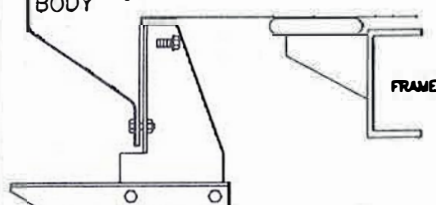

- ④ BEND STONE GUARD BY HAND AND KNEE TO FIT THE WHEEL WELL BEFORE INSTALLING TO RUNNING BOARD

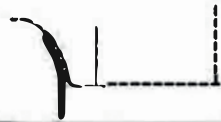

- ⑦ INSTALL END CAP TO BOARD WITH 3/8" SELF TAPPING BOLT

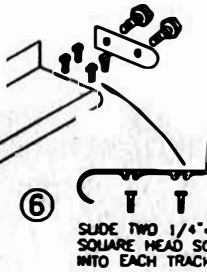

- ⑤ FASTEN FRONT STONE GUARD TO BOARDS WITH 3/8" SELF TAPPING BOLT. BEND STONE GUARD BY HAND AND KNEE TO FIT THE WHEEL WELL



- ⑥ SLIDE TWO 1/4"x5/8" SQUARE HEAD SCREW INTO EACH TRACK.

- ⑧ HOLD BOARD IN PLACE, WITH THE REAR RESTING ON THE BACK BRACKET
- NOTE: BE SURE THAT 1/4" BOLTS ARE PLACED INTO THE BRACKET STEP SUPPORT

- ⑨ SCREW THROUGH STONE GUARD INTO FENDERWELL LIP USING #14 BY 3/4 SELF DRILLING SCREWS.

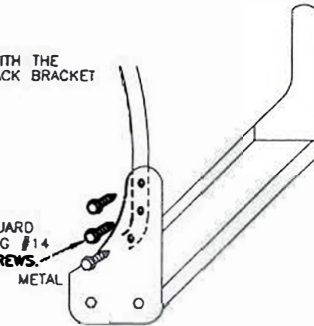

- 3 PLACES AT EACH STONE GUARD

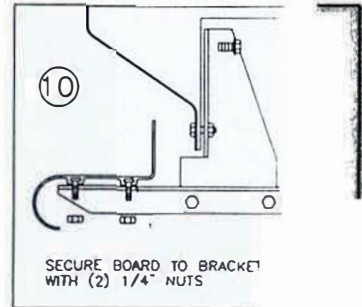

- ⑪ WITH BOARD LEVEL TIGHTEN ALL LOOSE BOLTS

- ⑫ REPEAT FOR OTHER SIDE