



99-CURRENT FORD SUPER DUTY STD. CAB

YOUR BRACKETS INSTALL IN FACTORY HOLES

INSTALLATION PARTS LIST:	QTY.	DESCRIPTION	QTY.	DESCRIPTION
	1	RUNNING BOARD 1 DRIVER & 1 PASSENGER	4	HORIZONTAL BRACKET, SUPPORT, 3124F
	1	STONE GUARD 2 LEFT & 2 RIGHT	4	5/16" CLIP NUT
	8	3/8"x1 SELF TAPPING SCREW	20	5/16"x 3/4" BOLT
	8	#14x3/4" TEK SCREW	18	5/16-18 HEX NUT
	8	1/4"x5/8" SQUARE HEAD SCREW	4	FLAT BRACKET, FL11
	8	1/4"-20 HEX NUT	1	END CAP 1 LEFT & 1 RIGHT

TOOLS REQUIRED: 5/16" DRILL • 1/2" HEX SOCKET • 1/2" WRENCH • 5/16" NUT DRIVER • 3/8" NUT DRIVER

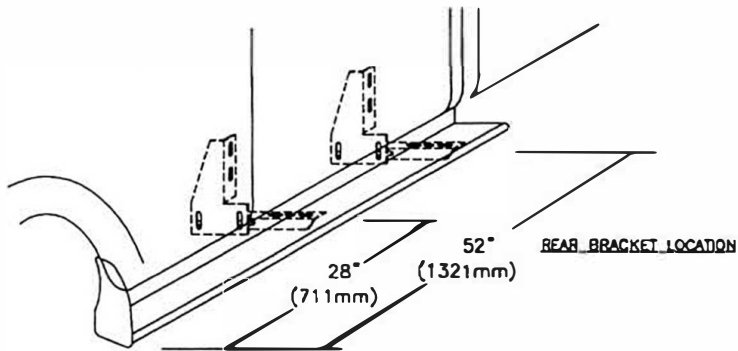

① (DRIVERS SIDE SHOWN)
MEASURE FROM FRONT WHEEL WELL TO BRACKET LOCATION
MARK THIS DIMENSION ON THE PINCH WELD

② BRACKET ASSEMBLY
ASSEMBLE WITH 5/16" BOLTS

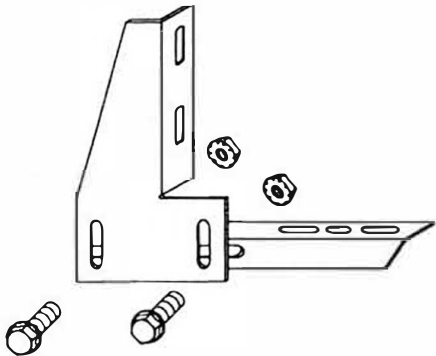

SLIDE CLIP NUT INTO BODY HOLES AT BRACKET LOCATIONS

③ BRACKET ASSEMBLY MOUNT TO BODY
ASSEMBLE WITH 5/16" BOLTS AND
NUT CUP AND 5/16" BOLT

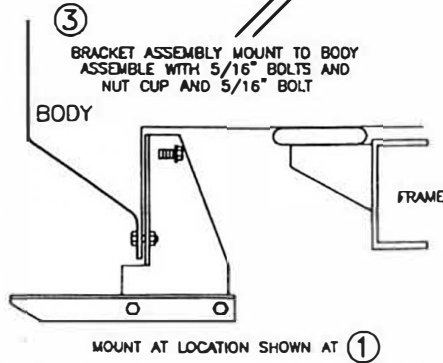

MOUNT AT LOCATION SHOWN AT ①

④ BEND STONE GUARD BY HAND AND
KNEE TO FIT THE WHEEL WELL.
BEFORE INSTALLING TO RUNNING BOARD

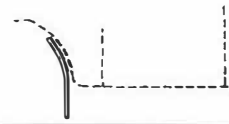

⑦ INSTALL END CAP TO BOARD
WITH 3/8" SELF TAPPING BOLT

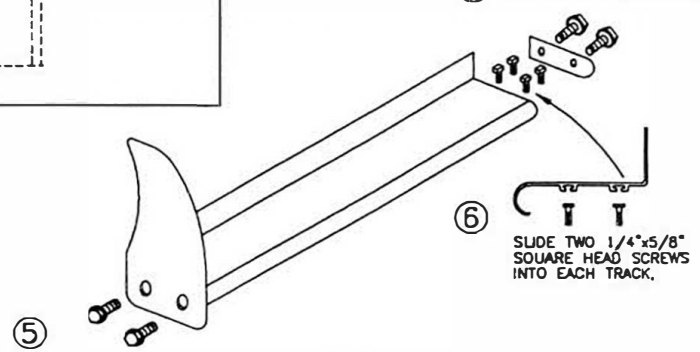

⑤ FASTEN FRONT STONE GUARD
TO BOARDS WITH 3/8" SELF
TAPPING BOLT. BEND STONE
GUARD BY HAND AND KNEE
TO FIT THE WHEEL WELL.

⑥ SLIDE TWO 1/4"x5/8"
SQUARE HEAD SCREWS
INTO EACH TRACK,

⑧ HOLD BOARD IN PLACE, WITH THE
REAR RESTING ON THE BACK BRACKET

NOTE: BE SURE THAT 1/4" BOLTS ARE PLACED
INTO THE BRACKET STEP SUPPORT

⑨ SCREW THROUGH STONE GUARD
INTO FENDERWELL LIP USING #14
BY 3/4 SELF DRILLING SCREWS.
MAKE SURE YOU DRILL INTO METAL

3 PLACES AT EACH STONE GUARD

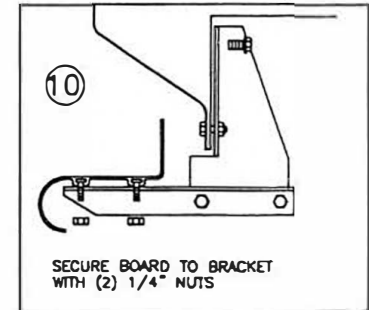
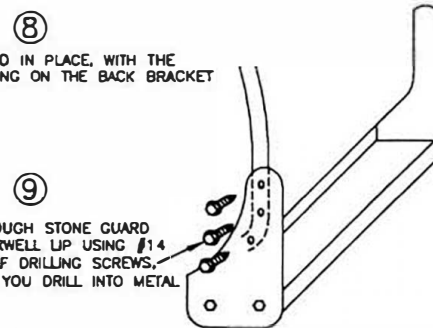

SECURE BOARD TO BRACKET
WITH (2) 1/4" NUTS

⑪ WITH BOARD LEVEL TIGHTEN
ALL LOOSE BOLTS

1N07A
04/15/04

⑫ REPEAT FOR OTHER SIDE