

# OWENS 99-CURRENT FORD H.D. DUALY BOARD

DRILLING INTO BODY AND FRAME IS REQUIRED.

INSTALLATION PARTS LIST	QTY.	DESCRIPTION	QTY.	DESCRIPTION
	1	DUALY BOARD 1 DRIVER & 1 PASSENGER	2	5/16" CLIP NUT
	1	STONE GUARD 1 LEFT & 1 RIGHT	20	5/16" 3/4" BOLT
	8	3/8"x1 SELF TAPPING SCREW	18	5/16"-18 HEX WASHER HEAD NUT
	6	#14x3/4" SHEET METAL SCREW	4	FLAT BRACKET, FL74
	6	1/4"x5/8" SQUARE HEAD SCREW	4	FLAT BRACKET, FL73 D&P
	8	1/4"-20 HEX NUT	2	HORIZONTAL BRACKET, 11 1/2", 3124F
	1	END CAP 1 LEFT & 1 RIGHT	2	HORIZONTAL BRACKET, 17 1/4", 3124G
			10	#14 X 3/4 TEX SCREW

TOOLS REQUIRED: 5/16" DRILL • 1/2" HEX SOCKET • 1/2" WRENCH • 5/16" NUT DRIVER • 3/8" NUT DRIVER

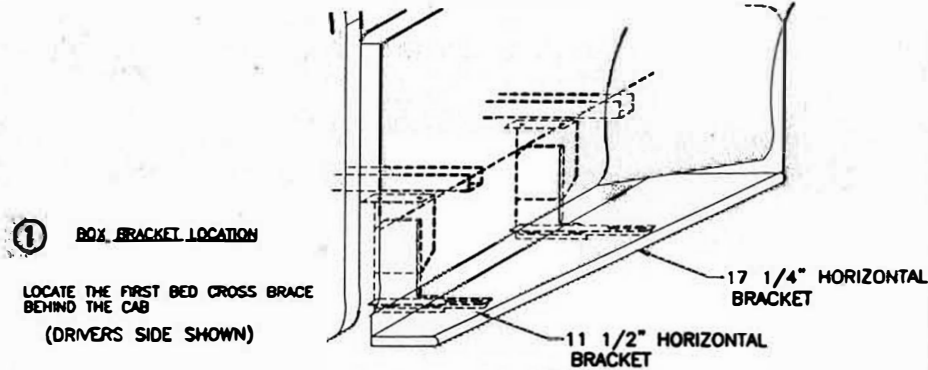

**2 BRACKET ASSEMBLY**  
ASSEMBLE WITH 5/16" BOLTS  
MOUNT THE ANGLE STRAP TO THE REAR BRACKET ONLY

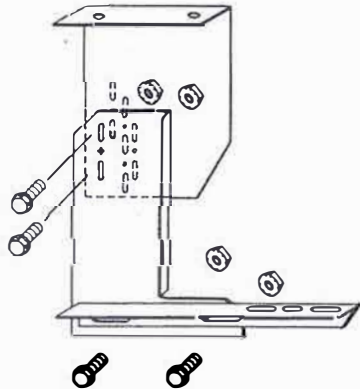

**3 FRONT BRACKET MOUNTING**  
PREDRILL A 5/16" HOLE NEAR THE END OF THE FRONT CROSSBRACE, SLIDE NUT CLIP INTO END OF CROSS BRACE AT BRACKET LOCATION  
BRACKET ASSEMBLY MOUNT TO BED, ASSEMBLE WITH 5/16" BOLTS, NUT CLIP AND #14 SELF DRILLING SCREW  
**REAR BRACKET MOUNTING**  
MOUNT LIKE THE FRONT BRACKET, BUT USE 2 #14 SCREWS TO MOUNT TO THE BED.

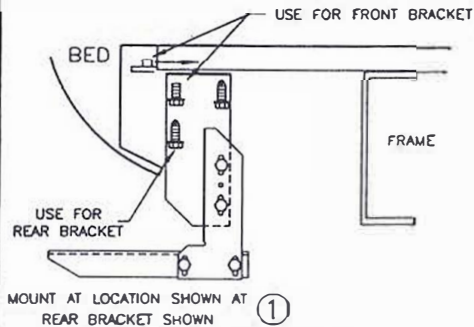

**4** BEND STONE GUARD BY HAND AND KNEE TO FIT THE WHEEL WELL BEFORE INSTALLING TO RUNNING BOARD

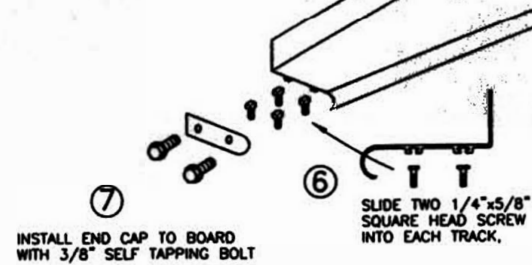

**8** HOLD BOARD IN PLACE, WITH THE BOARD RESTING ON THE BOX BRACKETS  
**NOTE:**  
BE SURE THAT 1/4" BOLTS ARE PLACED INTO THE BRACKET STEP SUPPORT

**9** SCREW THROUGH STONE GUARD INTO INNER STEEL FENDER LIP USING #14 BY 3/4" SHEET METAL SCREWS, MAKE SURE YOU DRILL INTO METAL. DO NOT DRILL INTO THE PLASTIC DUALY FENDERS  
3 PLACES AT EACH STONE GUARD

**11** WITH BOARD LEVEL TIGHTEN ALL LOOSE BOLTS

ISSUED 08/22/03

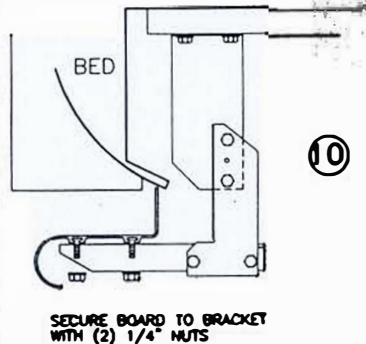

**12** REPEAT FOR OTHER SIDE