

INSTALLATION PARTS LIST:	QTY.	DESCRIPTION	QTY.	DESCRIPTION
	1	RUNNING BOARD 1 DRIVER & 1 PASSENGER	4	5/16" CUP NUT
	1	STONE GUARD 1 LEFT & 1 RIGHT	28	5/16" x 3/4" BOLT
	8	3/8"x1 SELF TAPPING SCREW	24	5/16-18 HEX WASHER HEAD NUT
	6	#14x3/4" SHEET METAL SCREW	4	FLAT BRACKET, FL74
	6	1/4"x5/8" SQUARE HEAD SCREW	4	FLAT BRACKET, FL73 D&P
	8	1/4-20 HEX NUT	2	HORIZONTAL BRACKET, SUPPORT, 3124F
	1	END CAP 1 LEFT & 1 RIGHT	2	HORIZONTAL BRACKET, 17 1/4", 3124G
	22	1/4" ANGLE STRAP, AS010	4	#14 X 3/4 TEX SCREW

TOOLS REQUIRED: 5/16" DRILL • 1/2" HEX SOCKET • 1/2" WRENCH • 5/16" NUT DRIVER • 3/8" NUT DRIVER

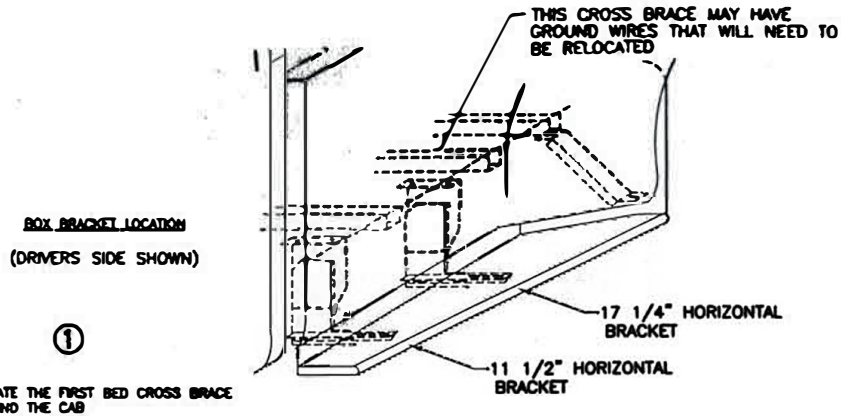

LOCATE THE FIRST BED CROSS BRACE BEHIND THE CAB

2
BRACKET ASSEMBLY
ASSEMBLE WITH 5/16" BOLTS

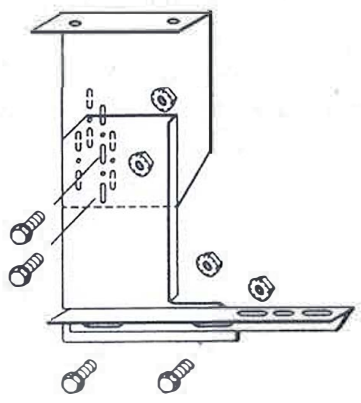

3
PREDRILL A 5/16" HOLE NEAR THE END OF THE CROSSBRACE
SLIDE NUT CUP INTO END OF CROSS BRACE AT BRACKET LOCATION

BRACKET ASSEMBLY MOUNT TO BED, ASSEMBLE WITH 5/16" BOLTS AND NUT CUP AND #14 SELF DRILLING SCREW

REPEAT FOR THE REAR BRACKET WITH THE 17 1/4" LONG HORIZONTAL BRACKET

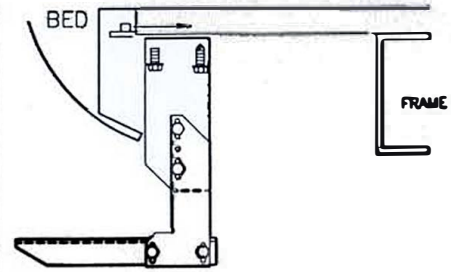

MOUNT AT LOCATION SHOWN AT 1

4
BEND STONE GUARD BY HAND AND KNEE TO FIT THE WHEEL WELL BEFORE INSTALLING TO RUNNING BOARD

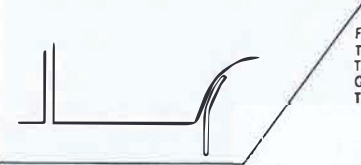

5
REMOVE FACTORY SCREW AT THIS HOLE LOCATION IT HOLDS THE FENDER TO A FENDER BRACE

FASTEN REAR STONE GUARD TO BOARDS WITH 3/8" SELF TAPPING BOLT. BEND STONE GUARD BY HAND AND KNEE TO FIT THE WHEEL WELL

7
SLIDE TWO 1/4"x5/8" SQUARE HEAD SCREW INTO EACH TRACK.

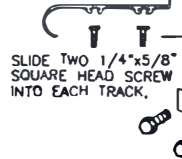

8
INSTALL END CAP TO BOARD WITH 3/8" SELF TAPPING BOLT

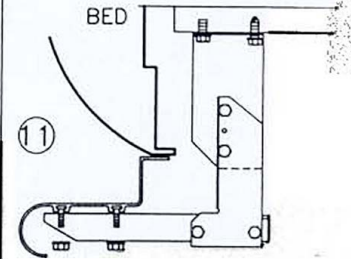

SECURE BOARD TO BRACKET WITH (2) 1/4" NUTS

9
HOLD BOARD IN PLACE, WITH THE FRONT RESTING ON THE BOX BRACKET

NOTE:
BE SURE THAT 1/4" BOLTS ARE PLACED INTO THE BRACKET STEP SUPPORT

10

SCREW THROUGH STONE GUARD INTO INNER STEEL FENDER LIP USING #14 BY 3/4 SHEET METAL SCREWS. MAKE SURE YOU DRILL INTO METAL.

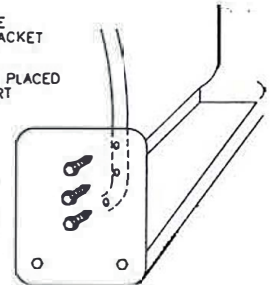

3 PLACES AT EACH STONE GUARD

13
DUALY FENDER
BOX BRACE

ATTACH THE TOP OF THE 22 1/4" ANGLE STRAP TO THE BOX BRACE. DRILL A 5/16" HOLE THROUGH THE BOX BRACE AND ASSEMBLE WITH A 5/16" NUT AND BOLT

12
INSTALL THE 22 1/4" STRAP BETWEEN THE BOARD AND THE FENDER, REINSTALL THE FACTORY BOLT MAKE SURE THE FACTORY BRACE IS INSTALLED

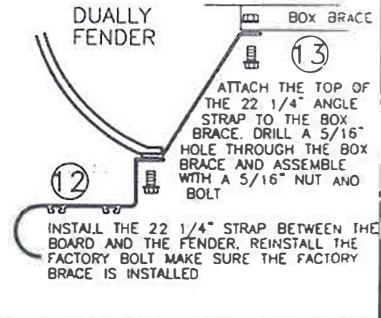

14
WITH BOARD LEVEL TIGHTEN ALL LOOSE BOLTS
NEWBOX 19227 08/12/03

15
REPEAT FOR OTHER SIDE