

**TOOLS REQUIRED:** 5/16" DRILL \* 1/2" HEX SOCKET \* 1/2" WRENCH \* 5/16" NUT DRIVER \* 3/8" NUT DRIVER

YOUR BRACKETS INSTALL IN FACTORY HOLES

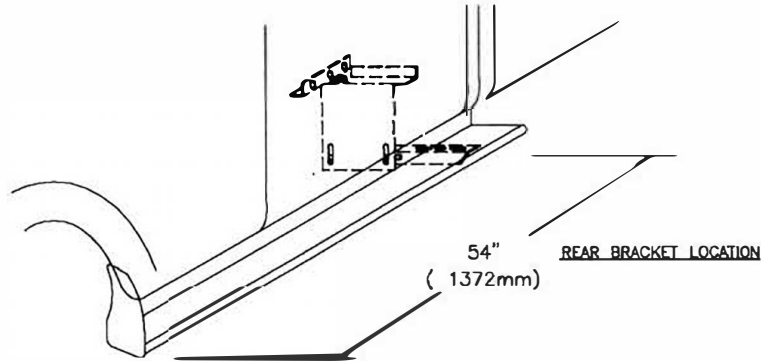

① MEASURE FROM FRONT WHEEL WELL TO BRACKET LOCATION  
MARK THIS DIMENSION ON THE PINCH WELD  
(DRIVERS SIDE SHOWN)

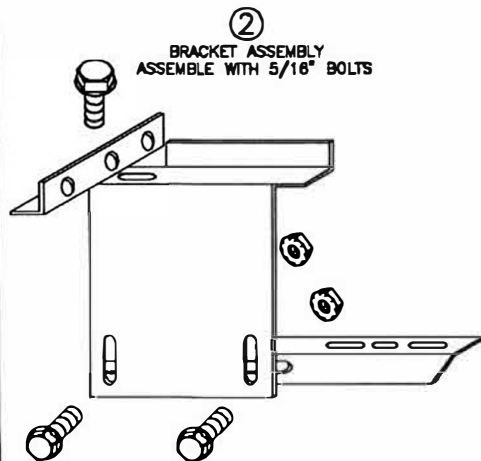

② BRACKET ASSEMBLY ASSEMBLE WITH 5/16" BOLTS

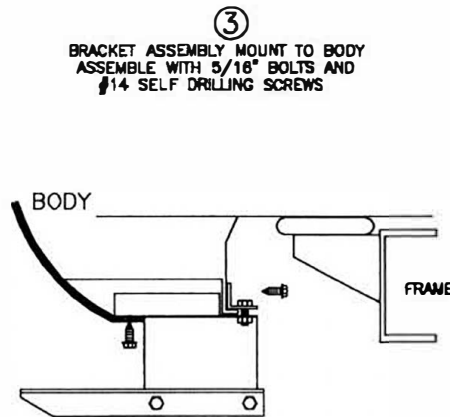

③ BRACKET ASSEMBLY MOUNT TO BODY ASSEMBLE WITH 5/16" BOLTS AND #14 SELF DRILLING SCREWS

MOUNT AT LOCATION SHOWN AT ①

④ BEND STONE GUARD BY HAND AND KNEE TO FIT THE WHEEL WELL BEFORE INSTALLING TO RUNNING BOARD



⑤ FASTEN FRONT STONE GUARD TO BOARDS WITH 3/8" SELF TAPPING BOLT. BEND STONE GUARD BY HAND AND KNEE TO FIT THE WHEEL WELL

⑦ INSTALL END CAP TO BOARD WITH 3/8" SELF TAPPING BOLT

⑥ SLIDE ONE 1/4"x5/8" SQUARE HEAD SCREW INTO EACH TRACK.

⑦ HOLD BOARD IN PLACE, WITH THE REAR RESTING ON THE BACK BRACKET

⑧ SCREW THROUGH STONE GUARD INTO FENDERWELL LIP USING #14 BY 3/4 SELF DRILLING SCREWS. MAKE SURE YOU DRILL INTO METAL

3 PLACES AT EACH STONE GUARD

NOTE: BE SURE THAT 1/4" BOLTS ARE PLACED INTO THE BRACKET STEP SUPPORT

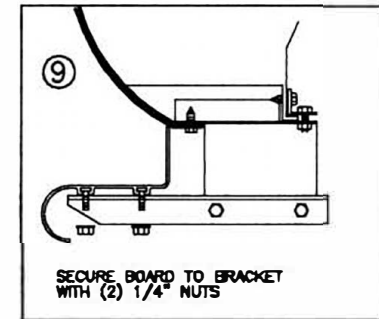

SECURE BOARD TO BRACKET WITH (2) 1/4" NUTS

⑩ WITH BOARD LEVEL TIGHTEN ALL LOOSE BOLTS

⑪ REPEAT FOR OTHER SIDE

INSTALLATION PARTS LIST:	QTY.	DESCRIPTION
	1	RUNNING BOARD 1 DRIVER & 1 PASSENGER
	1	STONE GUARD 1 LEFT & 1 RIGHT
	8	3/8"x1 SELF TAPPING SCREW
	10	#14x3/4" TEK SCREW
	4	1/4x5/8" SQUARE HEAD SCREW
	4	1/4-20 HEX NUT

QTY.	DESCRIPTION
1	END CAP 1 LEFT & 1 RIGHT
2	HORIZONTAL BRACKET, SUPPORT, 3124F
6	5/16"x 3/4" BOLT
6	5/16-18 HEX WASHER HEAD NUT
2	FLAT BRACKET, FL20-2" OR FL21-4"
2	6" HORIZONTAL BRACKET, BT07