

<b>Installation</b> 2007 to Current	<b>Chevy/GMC Full Size Pickup</b> New Body Style	<b>Product No.</b> Crew Cab 67052
--	---	--------------------------------------

	<u>Qty.</u>	<u>Description</u>		<u>Qty.</u>	<u>Description</u>	
<b>Installation</b>	A	2	Running Boards	E	26	5/16" x 3/4" Washer Head Bolts
	<b>Parts List:</b>	B	8	Channel Brackets	F	24
C		2	Step Pads	G	2	Clip Nuts
D		6	8mm Bolts	H	6	Shims
				I	2	5/16" x 1-1/2" Washer Head Bolts

**Tools Required:** 1/2" Hex Socket • 1/2" Wrench • Tape Measure

**NOTE** Painting of Premier boards is not necessary.

**1. Painting your Owens' Premier running boards.** To insure a proper paint finish, use a top quality auto paint system and follow the manufacturers instructions for painting ABS plastic.

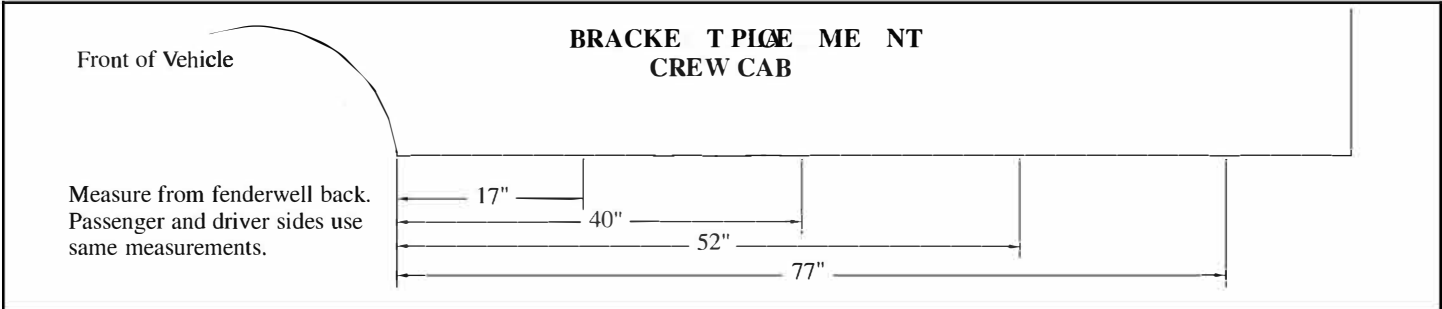

**2. Measure from front wheel well, back to dimensions shown above. Mark these bracket location centers.**

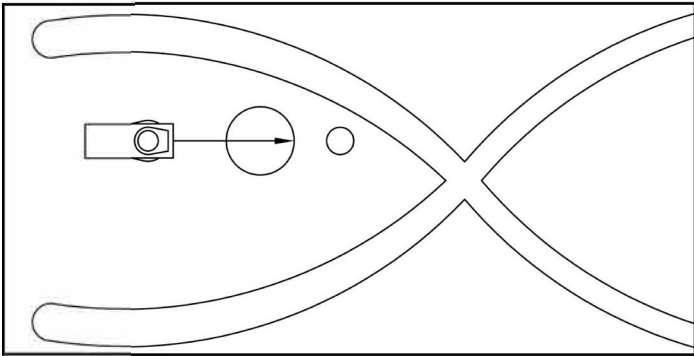

**3. Remove plastic plug from under body at 77" location and install clip nut as shown.**

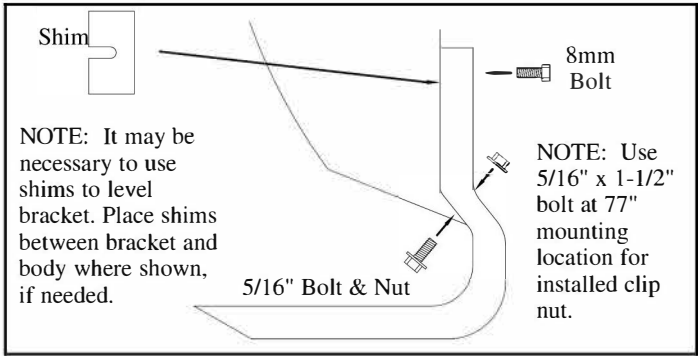

**4. Attach brackets to measured locations using 5/16" bolt and nut at factory pinchweld holes, and 8mm bolt into factory nut.**

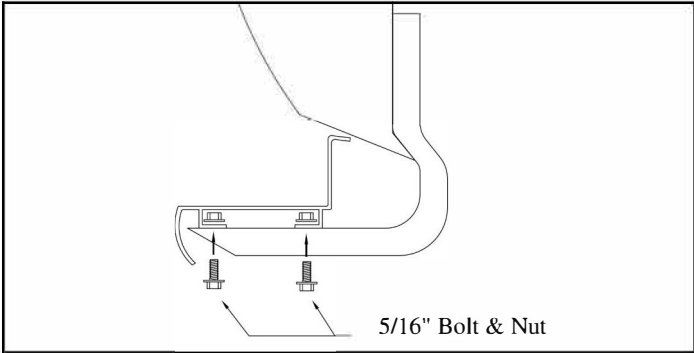

**5. Position board on brackets. Use proper slot to center board under doors. Attach with 5/16" bolts and nuts.**

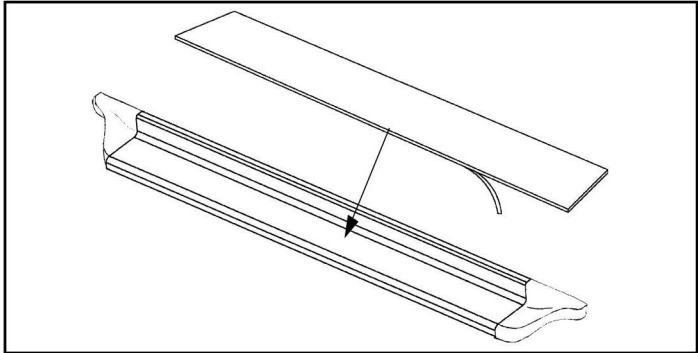

**6. Place step pad on running board. Peel off tape backing to secure. Install the Owens logo.**