

07-CURRENT GMC/CHEVY EXTENDED CAB

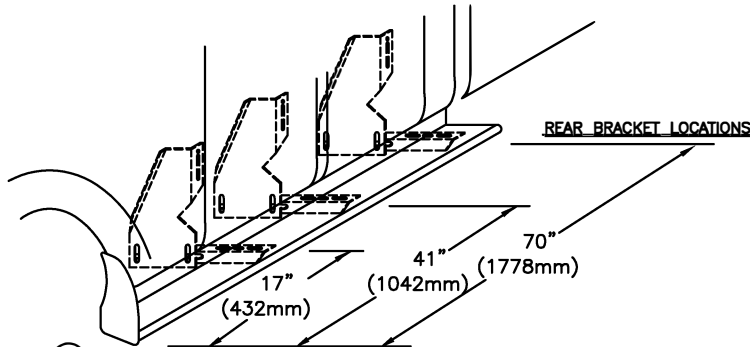

TOOLS REQUIRED: 5/16" DRILL * 1/2" HEX SOCKET * 1/2" WRENCH * 5/16" NUT DRIVER * 3/8" NUT DRIVER



① MEASURE FROM FRONT WHEEL WELL TO BRACKET LOCATIONS. MARK THIS DIMENSION ON THE PINCH WELD (DRIVERS SIDE SHOWN)

② BRACKET ASSEMBLY ASSEMBLE WITH 5/16" BOLTS

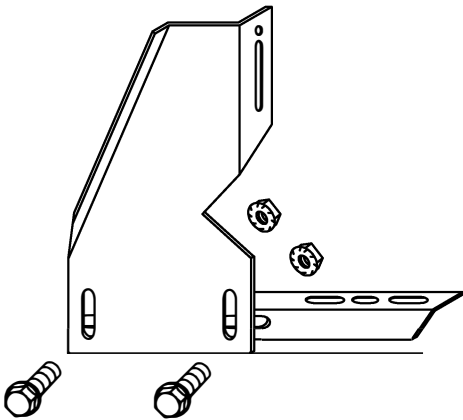

③ REMOVE RUBBER PLUGS FROM UNDERBODY AT MEASURED LOCATIONS AND INSTALL CLIP NUTS

④ SLIDE CLIP NUT INTO BODY HOLES AT BRACKET LOCATIONS

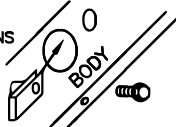

BRACKET ASSEMBLY MOUNT TO BODY; ASSEMBLE WITH 5/16" BOLTS AND NUTS THROUGH FACTORY PINCH WELD HOLES AND INSTALLED CLIP NUTS

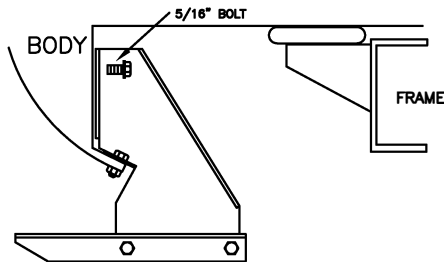

MOUNT AT LOCATIONS SHOWN AT ①

⑤ BEND STONE GUARD BY HAND AND KNEE TO FIT THE WHEEL WELL BEFORE INSTALLING TO RUNNING BOARD

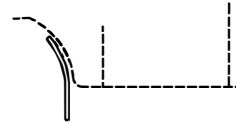

⑧ INSTALL END CAP TO BOARD WITH 3/8" SELF TAPPING BOLT

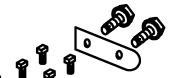

⑦ SLIDE THREE 1/4"x5/8" SQUARE HEAD SCREW INTO EACH TRACK,

⑥ FASTEN FRONT STONE GUARD TO BOARDS WITH 3/8" SELF TAPPING BOLT. BEND STONE GUARD BY HAND AND KNEE TO FIT THE WHEEL WELL

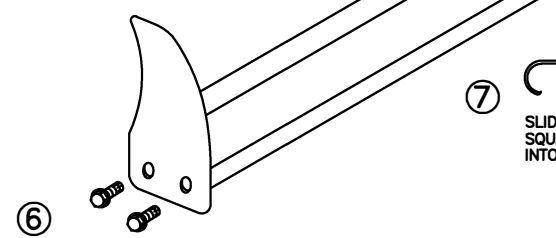

⑨ HOLD BOARD IN PLACE, WITH THE REAR RESTING ON THE BACK BRACKET
NOTE:
BE SURE THAT 1/4" BOLTS ARE PLACED INTO THE BRACKET STEP SUPPORT

⑩ SCREW THROUGH STONE GUARD INTO FENDERWELL LIP USING #14 BY 3/4 SELF DRILLING SCREWS, MAKE SURE YOU DRILL INTO METAL

3 PLACES AT EACH STONE GUARD

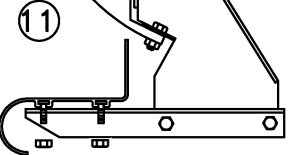
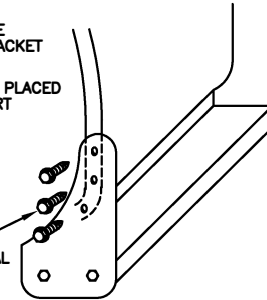

⑪ SECURE BOARD TO BRACKET WITH (2) 1/4" NUTS

⑫ WITH BOARD LEVEL TIGHTEN ALL LOOSE BOLTS

⑬ REPEAT FOR OTHER SIDE

INSTALLATION PARTS LIST

QTY.	DESCRIPTION
2	RUNNING BOARD 1 DRIVER & 1 PASSENGER
2	STONE GUARD 1 LEFT & 1 RIGHT
8	3/8"x1 SELF TAPPING SCREW
6	#14x3/4" TEK SCREW
12	1/4"x5/8" SQUARE HEAD SCREW
12	1/4"-20 HEX NUT

QTY.	DESCRIPTION
2	END CAP 1 LEFT & 1 RIGHT
24	5/16"x 3/4" WASHER HEAD BOLT
18	5/16"-18 HEX WASHER HEAD NUT
6	FLAT BRACKET, FL07
6	HORIZONTAL BRACKET, SUPPORT, 3124F
6	CLIP NUT

IN320
03/15/07