

# ZOWENS 88-98 CHEVY/GMC EXTENDED CAB

DRILLING INTO BODY AND FRAME IS REQUIRED.

QTY.	DESCRIPTION	QTY.	DESCRIPTION
1	RUNNING BOARD 1 DRIVER & 1 PASSENGER	16	5/16"x-3/4" BOLT
2	STONE GUARD 1 LEFT & 1 RIGHT	16	5/16-16 HEX WASHER HEAD NUT
8	3/8"x1 SELF TAPPING SCREW	4	FLAT BRACKET, FL90
12	#14x3/4" SHEET METAL SCREW	4	BENT TAB, BT39
8	1/4"x5/8" SQUARE HEAD SCREW	4	HORIZONTAL BRACKET, SUPPORT, 3124F
8	1/4-20 HEX NUT	1	END CAP 1 LEFT & 1 RIGHT

TOOLS REQUIRED: 5/16" DRILL • 1/2" HEX SOCKET • 1/2" WRENCH • 5/16" NUT DRIVER • 3/8" NUT DRIVER

MEASURE FROM FRONT WHEEL WELL TO BRACKET LOCATION  
MARK THIS DIMENSION ON THE PINCH WELD

(DRIVERS SIDE SHOWN)

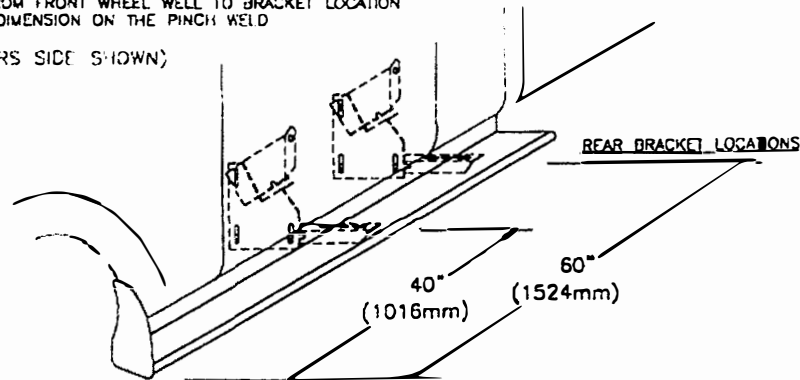

④ BEND STONE GUARD BY HAND AND KNEE TO FIT THE WHEEL WELL BEFORE INSTALLING TO RUNNING BOARD

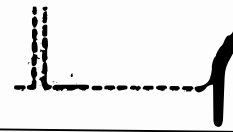

⑦ INSTALL END CAP TO BOARD WITH 3/8" SELF TAPPING BOLT



⑤ FASTEN FRONT STONE GUARD TO BOARDS WITH 3/8" SELF TAPPING BOLT. BEND STONE GUARD BY HAND AND KNEE TO FIT THE WHEEL WELL

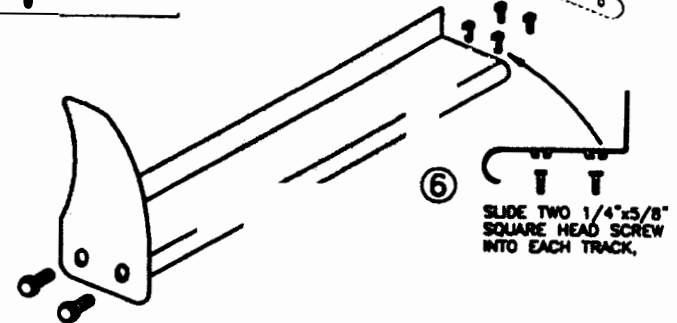

② BRACKET ASSEMBLY ASSEMBLE WITH 5/16" BOLTS LEAVE BOLTS LOOSE

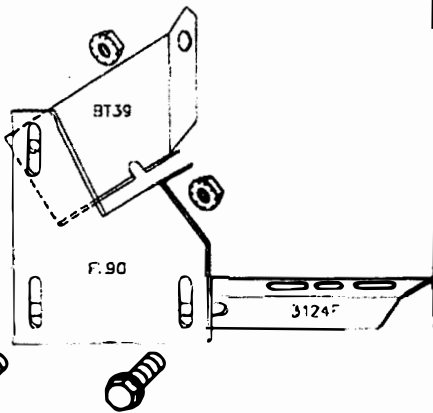

③ BRACKET ASSEMBLY MOUNT TO BODY ASSEMBLE WITH 5/16" BOLTS AND #14 SELF DRILLING TEX SCREWS

SLIDE BT39 AND FL90 OVER THE PINCH WELD FLANGE WITH BT39 UP AGAINST THE SIDE WALL. BOLT TIGHT TO THE PINCH WELD. INSERT ONE #14x3/4" SELF DRILLING SCREW THROUGH FL90 INTO THE PINCH WELD AND BT39

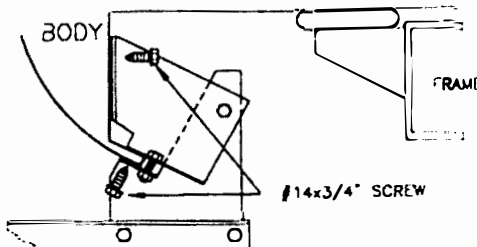

MOUNT AT LOCATION SHOWN AT ①

⑧ HOLD BOARD IN PLACE WITH THE REAR RESTING ON THE BACK BRACKET  
NOTE:  
BE SURE THAT 1/4" BOLTS ARE PLACED INTO THE BRACKET STEP SUPPORT

⑨ SCREW THROUGH STONE GUARD INTO FENDERWELL LIP USING #14 BY 3/4 SELF DRILLING SCREWS. MAKE SURE YOU DRILL INTO METAL

3 PLACES AT EACH STONE GUARD

⑪ WITH BOARD LEVEL TIGHTEN ALL LOOSE BOLTS

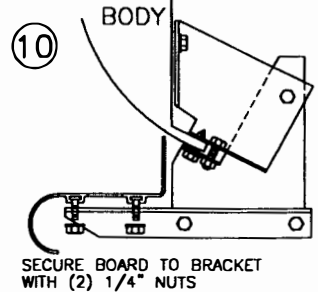

⑫ REPEAT FOR OTHER SIDE