



97-03 F150 EXTENDED CAB

YOUR BRACKETS INSTALL IN FACTORY HOLES

INSTALLATION PARTS LIST:	QTY.	DESCRIPTION	QTY.	DESCRIPTION
	1	RUNNING BOARD 1 DRIVER & 1 PASSENGER	1	END CAP 1 LEFT & 1 RIGHT
	1	STONE GUARD 1 LEFT & 1 RIGHT	2	5/16" CLIP NUT
	8	3/8"x1 SELF TAPPING SCREW	20	5/16"x 3/4" BOLT
	8	#14x3/4" TEK SCREW	18	5/16-18 HEX NUT
	8	1/4"x5/8" SQUARE HEAD SCREW	4	FLAT BRACKET, FLO5 D&P 2", FL46 D&P 4"
	8	1/4-20 HEX NUT	4	HORIZONTAL BRACKET, SUPPORT, 3124F

TOOLS REQUIRED: 5/16" DRILL • 1/2" HEX SOCKET • 1/2" WRENCH • 5/16" NUT DRIVER • 3/8" NUT DRIVER

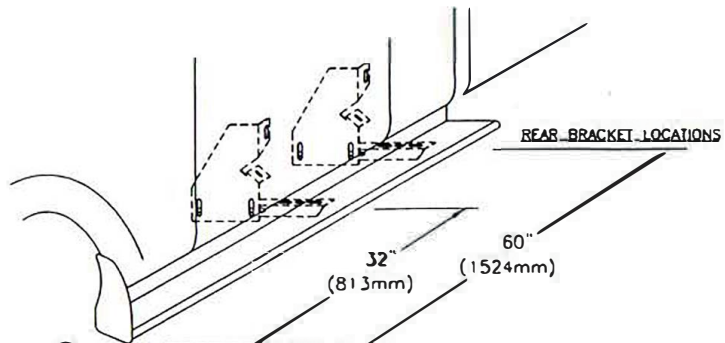

① (DRIVERS SIDE SHOWN)
MEASURE FROM FRONT WHEEL WELL TO BRACKET LOCATIONS. MARK THIS DIMENSION ON THE PINCH WELD

② BRACKET ASSEMBLY ASSEMBLE WITH 5/16" BOLTS

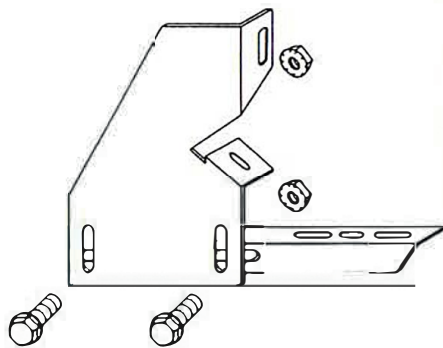

SLIDE NUT CUP INTO BODY HOLES AT BRACKET LOCATION AT 32"

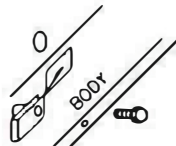

③ BRACKET ASSEMBLY MOUNT TO BODY @32" ASSEMBLE WITH 5/16" BOLTS AND NUT CUP AND 5/16" BOLT
BRACKET ASSEMBLY MOUNT TO BODY @60" ASSEMBLE WITH 5/16" BOLTS AND #14 SELF DRILLING SCREW

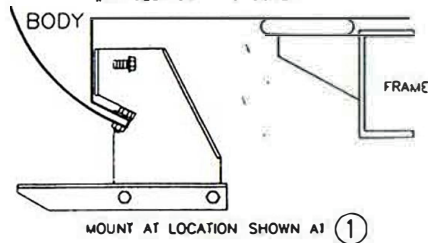

④ BEND STONE GUARD BY HAND AND KNEE TO FIT THE WHEEL WELL BEFORE INSTALLING TO RUNNING BOARD

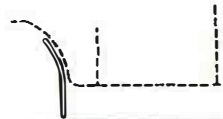

⑦ INSTALL END CAP TO BOARD WITH 3/8" SELF TAPPING BOLT



⑤ FASTEN FRONT STONE GUARD TO BOARDS WITH 3/8" SELF TAPPING BOLT. BEND STONE GUARD BY HAND AND KNEE TO FIT THE WHEEL WELL

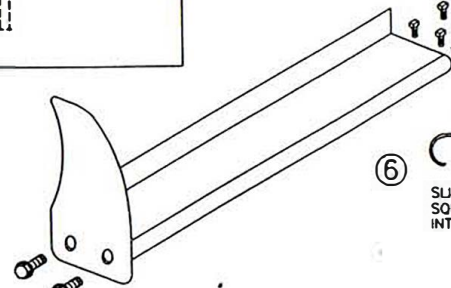

⑥ SLIDE TWO 1/4"x5/8" SQUARE HEAD SCREW INTO EACH TRACK.

⑧ HOLD BOARD IN PLACE, WITH THE REAR RESTING ON THE BACK BRACKET

⑨ SCREW THROUGH STONE GUARD INTO FENDERWELL LIP USING #14 BY 3/4 SELF DRILLING SCREWS. MAKE SURE YOU DRILL INTO METAL
3 PLACES AT EACH STONE GUARD

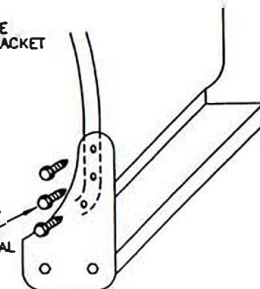

NOTE: BE SURE THAT 1/4" BOLTS ARE PLACED INTO THE BRACKET STEP SUPPORT

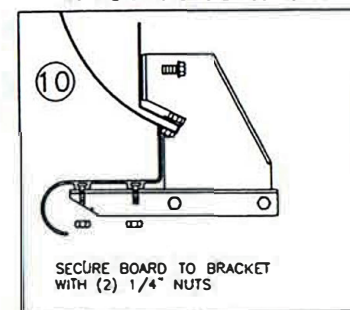

⑪ WITH BOARD LEVEL TIGHTEN ALL LOOSE BOLTS

1N229
06/06/03

⑫ REPEAT FOR OTHER SIDE