

07-CURRENT GMC/CHEVY STANDARD CAB

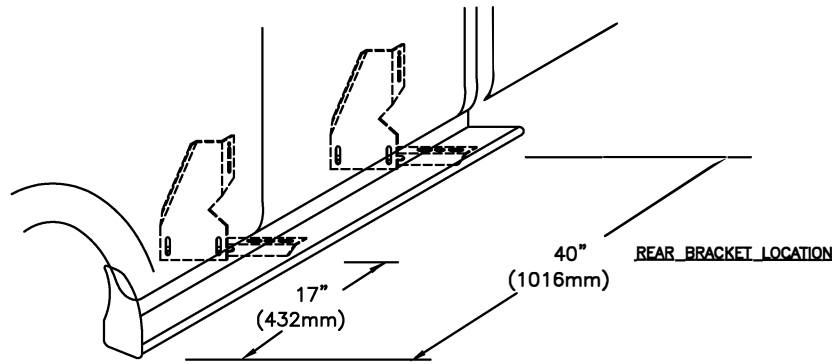

TOOLS REQUIRED: 5/16" DRILL * 1/2" HEX SOCKET * 1/2" WRENCH * 5/16" NUT DRIVER * 3/8" NUT DRIVER



① MEASURE FROM FRONT WHEEL WELL TO BRACKET LOCATION
MARK THIS DIMENSION ON THE PINCH WELD
(DRIVERS SIDE SHOWN)

② BRACKET ASSEMBLY
ASSEMBLE WITH 5/16" BOLTS

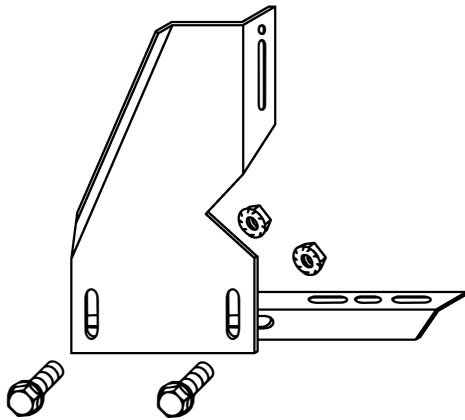

③ REMOVE RUBBER PLUGS FROM UNDERBODY AT MEASURED LOCATIONS AND INSTALL CLIP NUTS



BRACKET ASSEMBLY MOUNT TO BODY;
ASSEMBLE WITH 5/16" BOLTS AND NUTS
THROUGH FACTORY PINCH WELD HOLES
AND INSTALLED CLIP NUTS

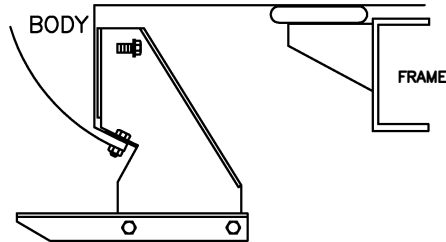

MOUNT AT LOCATION SHOWN AT ①

⑤ BEND STONE GUARD BY HAND AND KNEE TO FIT THE WHEEL WELL BEFORE INSTALLING TO RUNNING BOARD

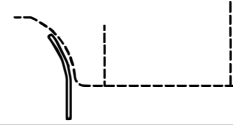

⑧ INSTALL END CAP TO BOARD WITH 3/8" SELF TAPPING BOLT



⑦ SLIDE TWO 1/4"x5/8" SQUARE HEAD SCREW INTO EACH TRACK,

⑥ FASTEN FRONT STONE GUARD TO BOARDS WITH 3/8" SELF TAPPING BOLT. BEND STONE GUARD BY HAND AND KNEE TO FIT THE WHEEL WELL

⑨ HOLD BOARD IN PLACE, WITH THE REAR RESTING ON THE BACK BRACKET
NOTE:
BE SURE THAT 1/4" BOLTS ARE PLACED INTO THE BRACKET STEP SUPPORT

⑩ SCREW THROUGH STONE GUARD INTO FENDERWELL LIP USING #14 BY 3/4 SELF DRILLING SCREWS. MAKE SURE YOU DRILL INTO METAL

3 PLACES AT EACH STONE GUARD

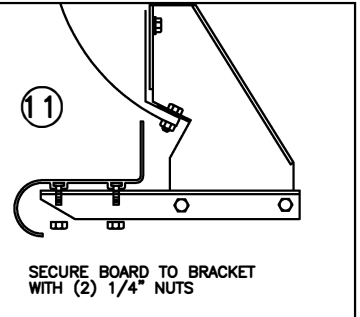

SECURE BOARD TO BRACKET WITH (2) 1/4" NUTS

⑫ WITH BOARD LEVEL TIGHTEN ALL LOOSE BOLTS

⑬ REPEAT FOR OTHER SIDE

INSTALLATION PARTS LIST:

QTY.	DESCRIPTION	QTY.	DESCRIPTION
2	RUNNING BOARD 1 DRIVER & 1 PASSENGER	2	END CAP 1 LEFT & 1 RIGHT
2	STONE GUARD 1 LEFT & 1 RIGHT	16	5/16"x 3/4" WASHER HEAD BOLT
8	3/8"x1 SELF TAPPING SCREW	12	5/16-18 HEX WASHER HEAD NUT
8	#14x3/4" TEK SCREW	4	FLAT BRACKET, FLO7
8	1/4x5/8" SQUARE HEAD SCREW	4	HORIZONTAL BRACKET, SUPPORT, 3124F
8	1/4-20 HEX NUT	4	CLIP NUT

IN322
03/15/07