

OWENS 97-03 F150 STANDARD CAB

YOUR BRACKETS INSTALL IN FACTORY HOLES

INSTALLATION PARTS LIST:	QTY.	DESCRIPTION	QTY.	DESCRIPTION
	1	RUNNING BOARD 1 DRIVER & 1 PASSENGER	1	END CAP 1 LEFT & 1 RIGHT
	1	STONE GUARD 1 LEFT & 1 RIGHT	2	5/16" CLIP NUT
	8	3/8"x1 SELF TAPPING SCREW	10	5/16"x 3/4" BOLT
	6	#14x3/4" TEK SCREW	8	5/16-18 HEX WASHER HEAD NUT
	4	1/4"x5/8" SQUARE HEAD SCREW	2	FLAT BRACKET, FLO5 D&P 2", FL46 D&P 4"
	4	1/4-20 HEX NUT	2	HORIZONTAL BRACKET, SUPPORT, 3124F

TOOLS REQUIRED: 5/16" DRILL • 1/2" HEX SOCKET • 1/2" WRENCH • 5/16" NUT DRIVER • 3/8" NUT DRIVER

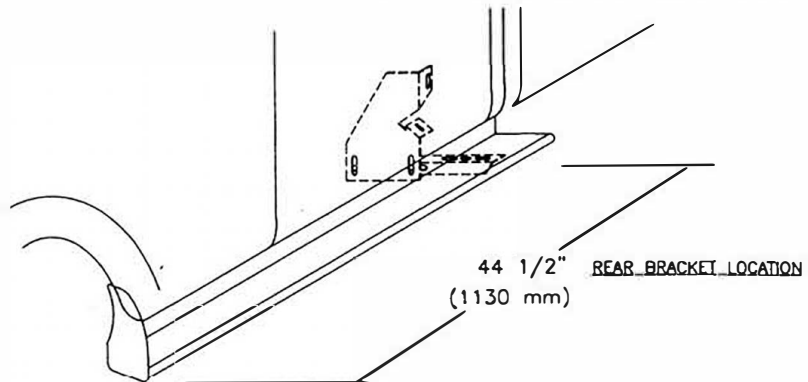

① (DRIVERS SIDE SHOWN)
MEASURE FROM FRONT WHEEL WELL TO BRACKET LOCATION
MARK THIS DIMENSION ON THE PINCH WELD

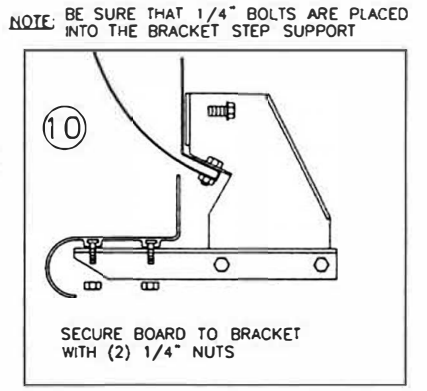
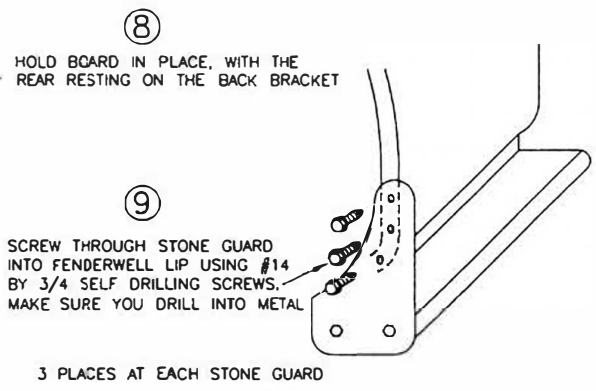
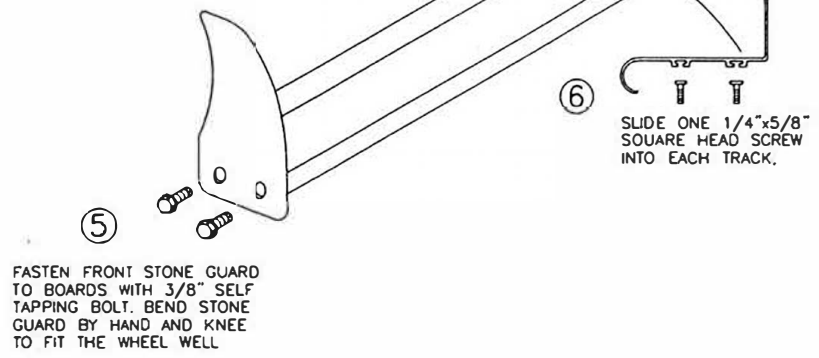
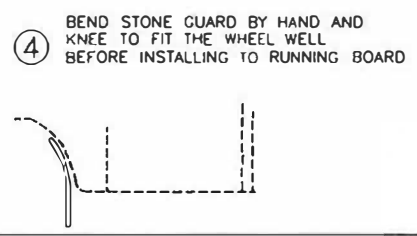
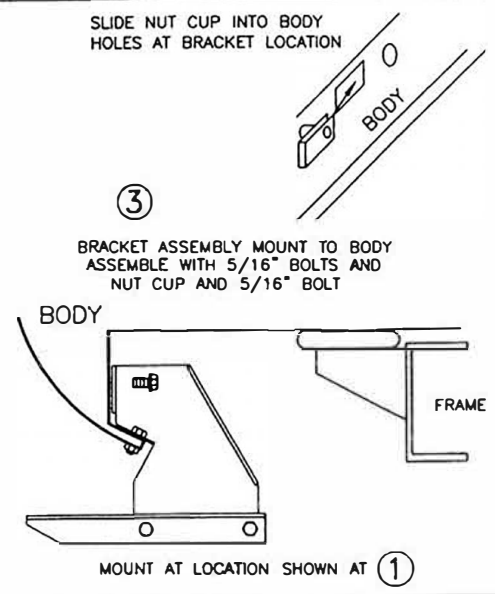
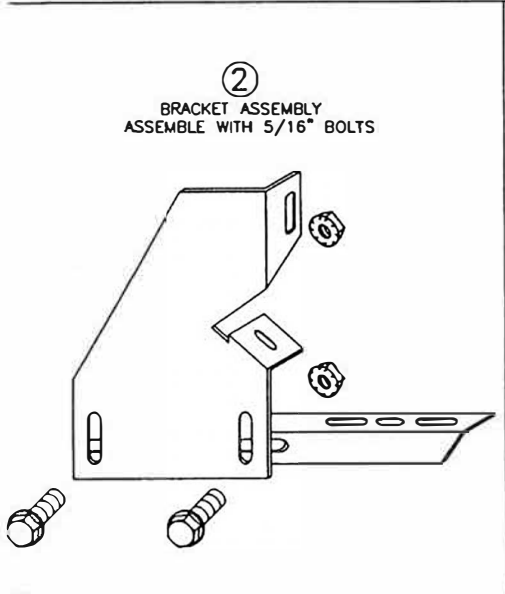

⑪ WITH BOARD LEVEL TIGHTEN
ALL LOOSE BOLTS

⑫ REPEAT FOR OTHER SIDE