

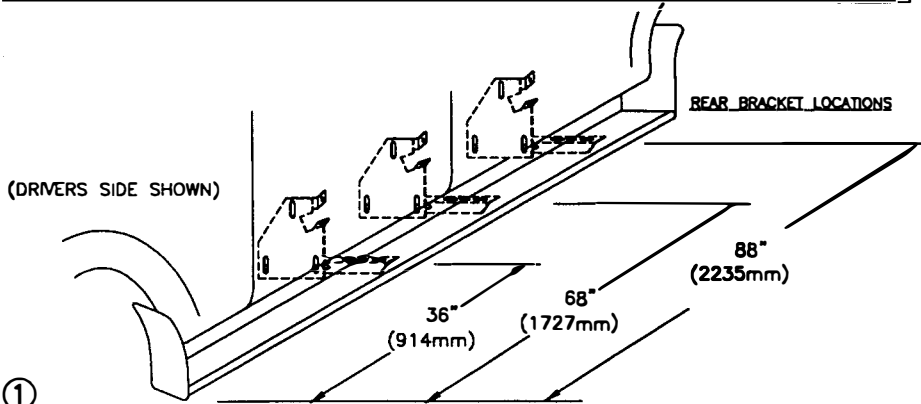

04-CUR. SPRINTER VANS
DRILLING INTO THE BODY IS REQUIRED

INSTALLATION PARTS LIST:	QTY.	DESCRIPTION	QTY.	DESCRIPTION
	2	RUNNING BOARD 1 DRIVER & 1 PASSENGER	6	HORIZONTAL BRACKET, SUPPORT, 3124F
	4	STONE GUARD 2 LEFT & 2 RIGHT	24	5/16" x 3/4" BOLT
	8	3/8" x 1 SELF TAPPING SCREW	24	5/16-18 HEX WASHER HEAD NUT
	24	#14 x 3/4" TEK SCREW	6	FLAT BRACKET, FL100
	12	1/4 x 5/8" SQUARE HEAD SCREW	2	FENDER BRACE BT46
	12	1/4-20 HEX NUT	6	BENT TAB AS01

TOOLS REQUIRED: 5/16" DRILL • 1/2" HEX SOCKET • 1/2" WRENCH • 5/16" NUT DRIVER • 3/8" NUT DRIVER



① MEASURE FROM FRONT WHEEL WELL TO BRACKET LOCATIONS. MARK THIS DIMENSION ON THE PINCH WELD

② BRACKET ASSEMBLY ASSEMBLE WITH 5/16" BOLTS

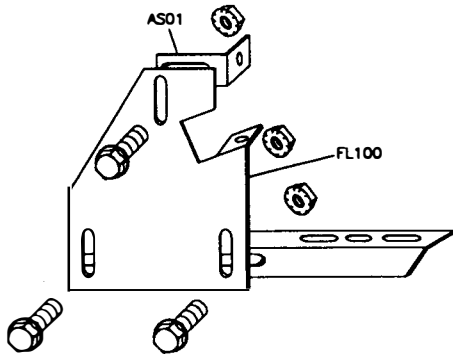

③ BRACKET ASSEMBLY MOUNT TO BODY

PREDRILL A 5/16" HOLE THROUGH THE PINCH WELD. ATTACH FL100 BRACKET TO THE BODY WITH 5/16" BOLT AND NUT, LOOSLY TIGHTEN. ATTACH THE AS01 BENT TAB TO THE BODY PANEL WITH A #14 x 3/4" SELF DRILLING SCREW.

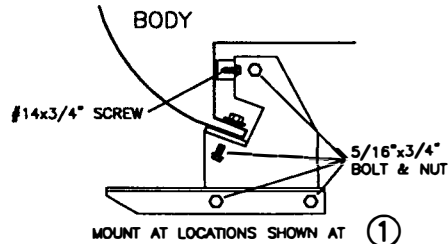

④ BEND STONE GUARD BY HAND AND KNEE TO FIT THE WHEEL WELL BEFORE INSTALLING TO RUNNING BOARD

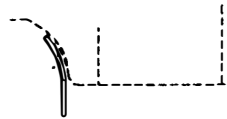

⑤ MEASURE UP 4-6" IN THE REAR WHEEL WELLS AND ATTACH A BT46 ON EACH SIDE. CHECK FOR THE BEST FIT INTO STEEL BEFORE ATTACHING WITH #14 SCREWS.

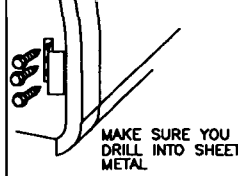

MAKE SURE YOU DRILL INTO SHEET METAL

⑥ FASTEN FRONT STONE GUARD TO BOARDS WITH 3/8" SELF TAPPING BOLT. BEND STONE GUARD BY HAND AND KNEE TO FIT THE WHEEL WELL

INSTALL STONE GUARD TO OTHER END OF BOARD

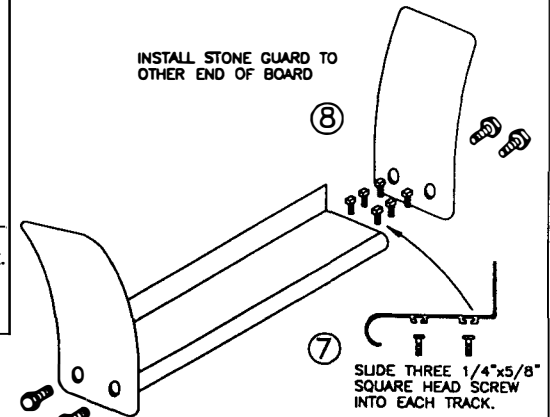

⑦ SLIDE THREE 1/4" x 5/8" SQUARE HEAD SCREW INTO EACH TRACK.

⑨ HOLD BOARD IN PLACE, WITH THE REAR RESTING ON THE BACK BRACKET

⑩

SCREW THROUGH FRONT STONE GUARDS INTO FENDERWELL UP USING #14 x 3/4" SELF DRILLING SCREWS. MAKE SURE YOU DRILL INTO METAL.

NOTE: BE SURE THAT 1/4" BOLTS ARE PLACED INTO THE BRACKET STEP SUPPORT

3 PLACES AT EACH STONE GUARD

⑪

IN THE REAR DRILL ONLY INTO FENDER BRACKET BT46. DO NOT DRILL INTO THE PLASTIC FENDER FLAIR - IT WILL CRACK

⑫

SECURE BOARD TO BRACKET WITH (2) 1/4" NUTS

⑬

WITH BOARD LEVEL TIGHTEN ALL LOOSE BOLTS

IN275
11/26/04

⑭

REPEAT FOR OTHER SIDE