



# 87-96 FORD F150 EXTENDED CAB

DRILLING INTO BODY AND FRAME IS REQUIRED.

INSTALLATION PARTS LIST:	QTY.	DESCRIPTION	QTY.	DESCRIPTION
	1	RUNNING BOARD 1 DRIVER & 1 PASSENGER	4	1/4" CARRIAGE BOLT
	1	STONE GUARD 1 LEFT & 1 RIGHT	14	5/16"x 3/4" BOLT
	8	3/8"x1 SELF TAPPING SCREW	14	5/16-18 HEX WASHER HEAD NUT
	14	#14x3/4" SHEET METAL SCREW	4	FLAT BRACKET, FL20
	8	1/4"x5/8" SQUARE HEAD SCREW	4	FLAT BRACKET, FL75
	12	1/4-20 HEX NUT	4	HORIZONTAL BRACKET, SUPPORT, .J124F
	1	END CAP 1 LEFT & 1 RIGHT		

TOOLS REQUIRED: 5/16" DRILL • 1/2" HEX SOCKET • 1/2" WRENCH • 5/16" NUT DRIVER • 3/8" NUT DRIVER

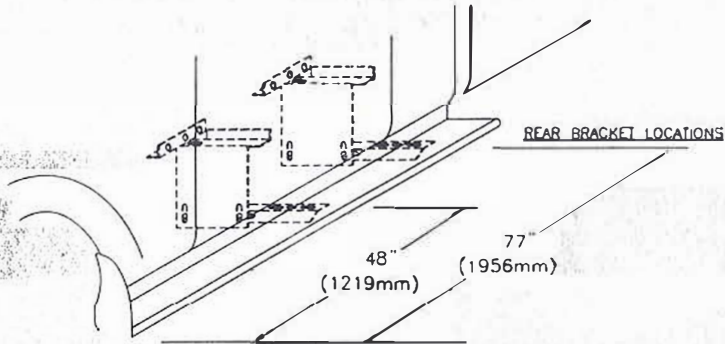

1 MEASURE FROM FRONT WHEEL WELL TO BRACKET LOCATION MARK THIS DIMENSION ON THE PINCH WELD

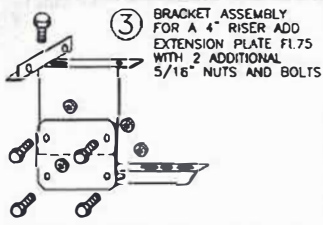

3 BRACKET ASSEMBLY FOR A 4" RISER ADD EXTENSION PLATE FL75 WITH 2 ADDITIONAL 5/16" NUTS AND BOLTS

4 BRACKET ASSEMBLY MOUNT TO BODY ASSEMBLE WITH 1/4" BOLTS AND #14 SELF DRILLING SCREWS

USE 2 #14x3/4" SELF DRILLING SCREWS TO SECURE TO BODY DRILL 9/32" DIA. HOLE THROUGH PINCH WELD AND BRACKET FL20 USE 1/4" CARRIAGE BOLT AND NUT. TIGHTEN TO 12 FT. LBS.

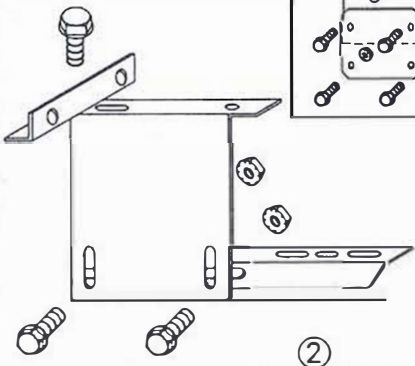

2 BRACKET ASSEMBLY ASSEMBLE WITH 5/16" BOLTS BRACKET SHOWN IS FOR A 2" RISER

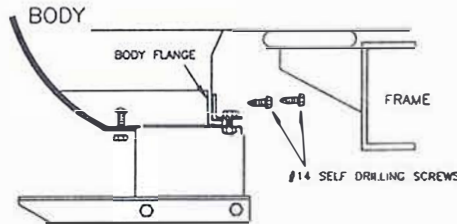

MOUNT AT LOCATION SHOWN AT 1

5 BEND STONE GUARD BY HAND AND KNEE TO FIT THE WHEEL WELL BEFORE INSTALLING TO RUNNING BOARD



8 INSTALL END CAP TO BOARD WITH 3/8" SELF TAPPING BOLT



6

FASTEN FRONT STONE GUARD TO BOARDS WITH 3/8" SELF TAPPING BOLT. BEND STONE GUARD BY HAND AND KNEE TO FIT THE WHEEL WELL

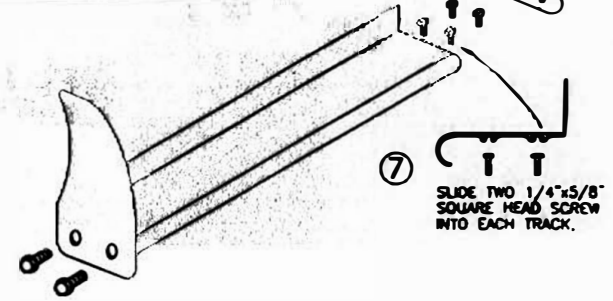

7 SLIDE TWO 1/4"x5/8" SQUARE HEAD SCREW INTO EACH TRACK.

9

HOLD BOARD IN PLACE, WITH THE REAR RESTING ON THE BACK BRACKET

10

SCREW THROUGH STONE GUARD INTO FENDERWELL LIP USING #14 BY 3/4" SELF DRILLING SCREWS. MAKE SURE YOU DRILL INTO METAL

3 PLACES AT EACH STONE GUARD

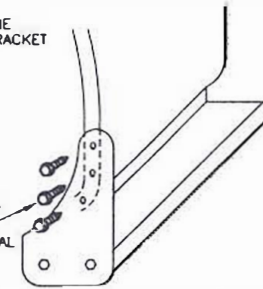

NOTE: BE SURE THAT 1/4" BOLTS ARE PLACED INTO THE BRACKET STEP SUPPORT

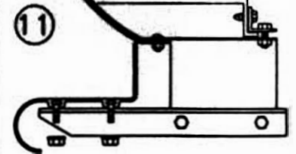

11 SECURE BOARD TO BRACKET WITH (2) 1/4" NUTS

12

WITH BOARD LEVEL TIGHTEN ALL LOOSE BOLTS

IN241 08/22/03

13

REPEAT FOR OTHER SIDE