

03-CURRENT DODGE BOX BOARD

DRILLING INTO BODY AND FRAME IS REQUIRED.

INSTALLATION PARTS LIST	QTY.	DESCRIPTION	QTY.	DESCRIPTION
	1	RUNNING BOARD 1 DRIVER & 1 PASSENGER	2	5/16" CUP NUT
	1	STONE GUARD 1 LEFT & 1 RIGHT	10	5/16"x 3/4" BOLT
	8	3/8"x1 SELF TAPPING SCREW	8	5/16-18 HEX WASHER HEAD NUT
	6	#14x3/4" SHEET METAL SCREW	2	FLAT BRACKET, FL74
	4	1/4"x5/8" SQUARE HEAD SCREW	2	FLAT BRACKET, FL73 D&P
	4	1/4-20 HEX NUT	2	HORIZONTAL BRACKET, SUPPORT, 3124I
	1	END CAP 1 LEFT & 1 RIGHT	2	#14 X 3/4 TEX SCREW

TOOLS REQUIRED: 5/16" DRILL • 1/2" HEX SOCKET • 1/2" WRENCH • 5/16" NUT DRIVER • 3/8" NUT DRIVER

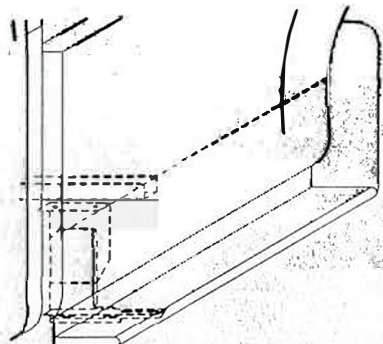

BOX BRACKET LOCATION (DRIVERS SIDE SHOWN)

① LOCATE THE FIRST BED CROSS BRACE BEHIND THE CAB

② BRACKET ASSEMBLY ASSEMBLE WITH 5/16" BOLTS

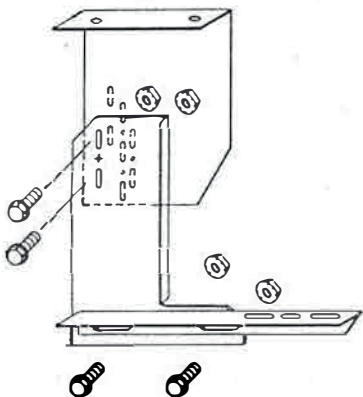

③ PRIDRILL A 5/16" HOLE NEAR THE END OF THE CROSSBRACE. SLIDE NUT CUP INTO END OF CROSS BRACE AT BRACKET LOCATION

BRACKET ASSEMBLY MOUNT TO BED ASSEMBLY WITH 5/16" BOLTS AND NUT CUP AND #14 SELF DRILLING SCREW

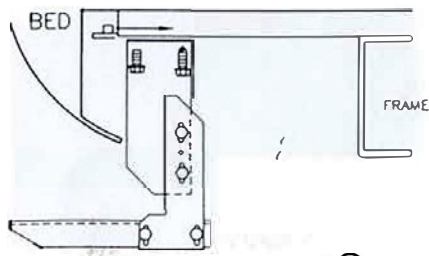

MOUNT AT LOCATION SHOWN AT ①

④ BEND STONE GUARD BY HAND AND KNEE TO FIT THE WHEEL WELL BEFORE INSTALLING TO RUNNING BOARD

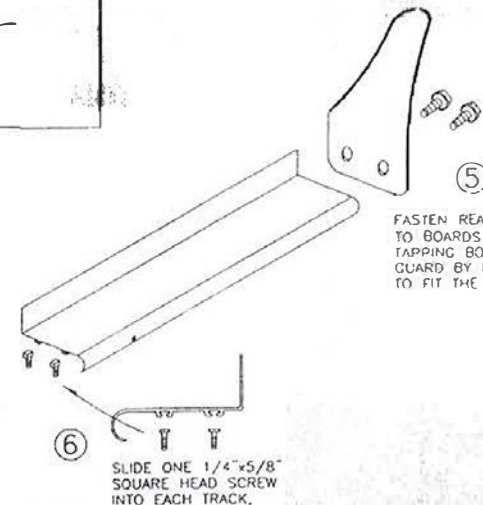

⑤ FASTEN REAR STONE GUARD TO BOARDS WITH 3/8" SELF TAPPING BOLT. BEND STONE GUARD BY HAND AND KNEE TO FIT THE WHEEL WELL.

⑦ INSTALL END CAP TO BOARD WITH 3/8" SELF TAPPING BOLT

⑥ SLIDE ONE 1/4"x5/8" SQUARE HEAD SCREW INTO EACH TRACK.

⑧ HOLD BOARD IN PLACE, WITH THE FRONT RESTING ON THE BOX BRACKET
NOTE: BE SURE THAT 1/4" BOLTS ARE PLACED INTO THE BRACKET STEP SUPPORT

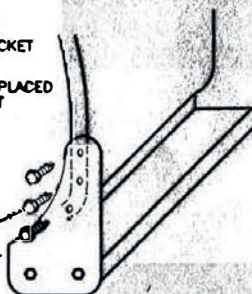

⑨ SCREW THROUGH STONE GUARD INTO FENDERWELL LIP USING #14 BY 3/4 SHEET METAL SCREWS. MAKE SURE YOU DRILL INTO METAL. 3 PLACES AT EACH STONE GUARD

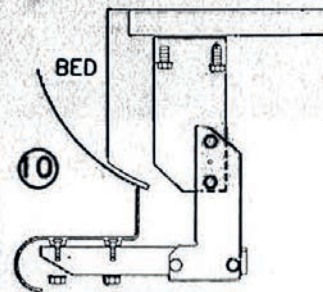

⑩ SECURE BOARD TO BRACKET WITH (2) 1/4" NUTS

⑪ WITH BOARD LEVEL TIGHTEN ALL LOOSE BOLTS

⑫ REPEAT FOR OTHER SIDE