

1992-CURRENT FORD VAN

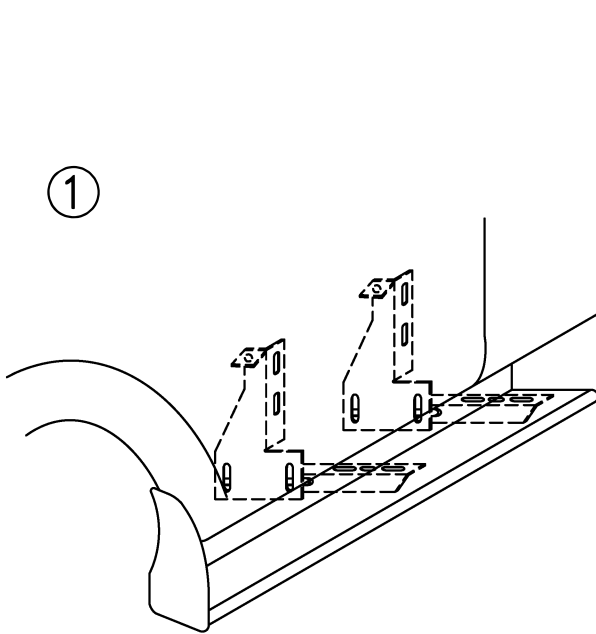

TOOLS REQUIRED: 5/16" DRILL * 1/2" HEX SOCKET * 1/2" WRENCH * 5/16" NUT DRIVER * 3/8" NUT DRIVER

①



DRIVER SIDE SHOWN.

MEASURE FROM FRONT WHEEL WELL TO BRACKET LOCATIONS. MARK THIS DIMENSION ON THE PINCH WELD

BRACKET LOCATION DRIVER SIDE: 14" AND 38"
BRACKET LOCATION PASSENGER SIDE: 38" 56" AND 76"

(DRIVERS SIDE SHOWN)

②

BRACKET ASSEMBLY
ASSEMBLE WITH 5/16" BOLTS

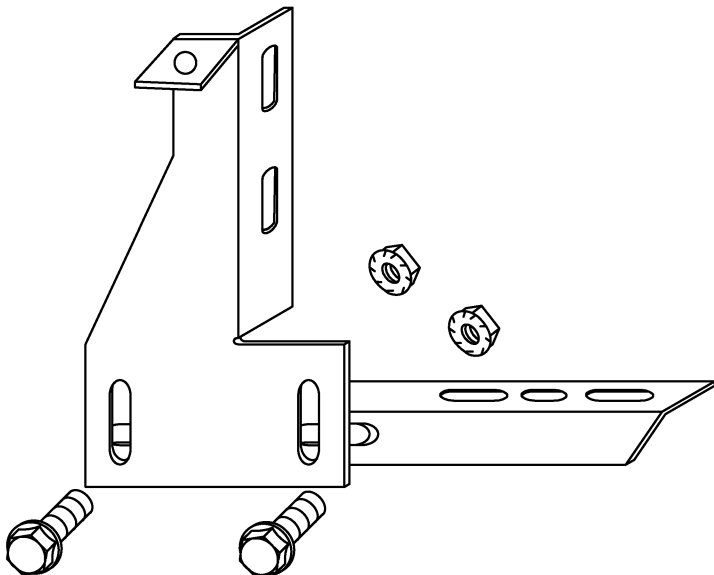

③

USE ONE SELF DRILLING SCREW INTO THE BODY

BODY

FRAME

DRILL A $\frac{5}{16}$ " HOLE IN THE PINCH WELD AND ATTACH WITH $\frac{5}{16}$ " BOLT AND NUT

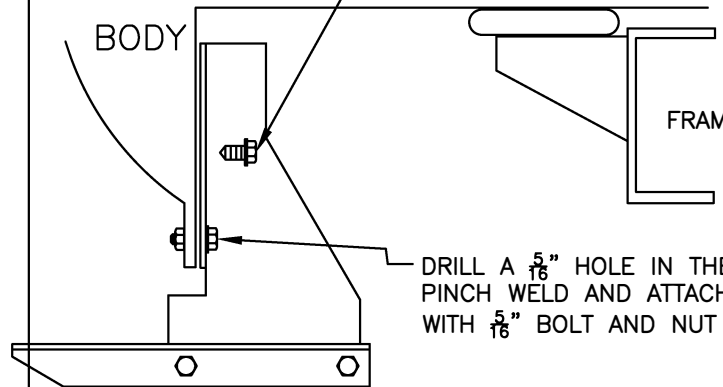

MOUNT AT LOCATIONS SHOWN AT ①

④

BEND STONE GUARD BY HAND AND KNEE TO FIT THE WHEEL WELL BEFORE INSTALLING TO RUNNING BOARD

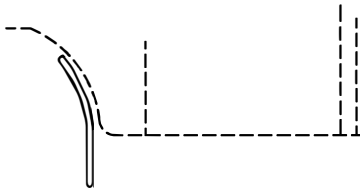

⑦

INSTALL END CAP TO BOARD WITH 3/8" SELF TAPPING BOLT

⑥

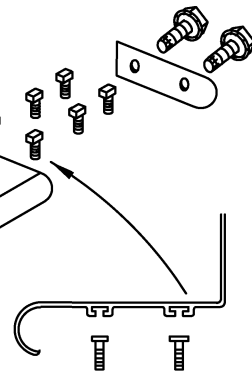

SLIDE ONE 1/4"x5/8" SQUARE HEAD SCREW FOR EACH BRACKET INTO TRACK.

⑤

FASTEN FRONT STONE GUARD TO BOARDS WITH 3/8" SELF TAPPING BOLT. BEND STONE GUARD BY HAND AND KNEE TO FIT THE WHEEL WELL

ON PASSENGER SIDE USE THE INCLUDED STONE GUARD AND NOT AN END CAP.

⑧

HOLD BOARD IN PLACE, WITH THE REAR RESTING ON THE BACK BRACKET

NOTE:

BE SURE THAT 1/4" BOLTS ARE PLACED INTO THE BRACKET STEP SUPPORT

⑨

SCREW THROUGH STONE GUARD INTO FENDERWELL LIP USING #14 BY 3/4 SELF DRILLING SCREWS, MAKE SURE YOU DRILL INTO METAL

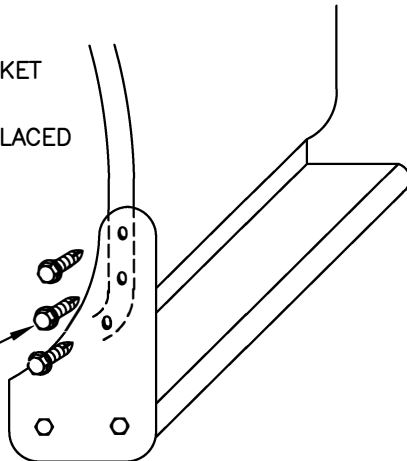

3 PLACES AT EACH STONE GUARD

⑩

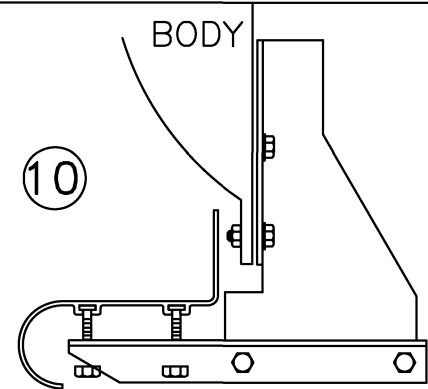

SECURE BOARD TO BRACKET WITH 1/4" NUTS

⑪

WITH BOARD LEVEL TIGHTEN ALL LOOSE BOLTS

⑫

REPEAT FOR OTHER SIDE