

87-96 F-150 CREW CAB

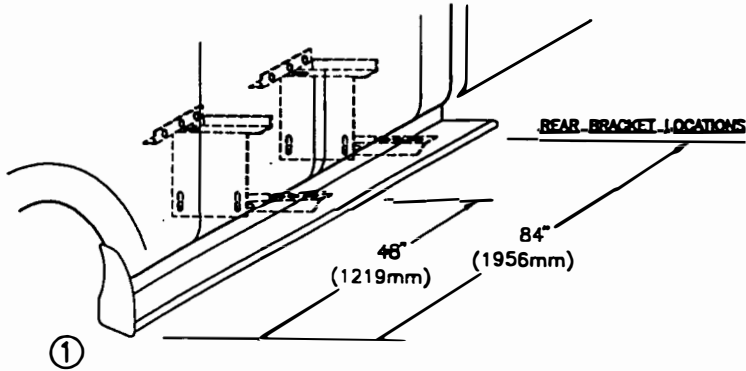

TOOLS REQUIRED: 5/16" DRILL • 1/2" HEX SOCKET • 1/2" WRENCH • 5/16" NUT DRIVER • 3/8" NUT DRIVER

YOUR BRACKETS INSTALL IN FACTORY HOLES



MEASURE FROM FRONT WHEEL WELL TO BRACKET LOCATIONS. MARK THIS DIMENSION ON THE PINCH WELD

(DRIVERS SIDE SHOWN)

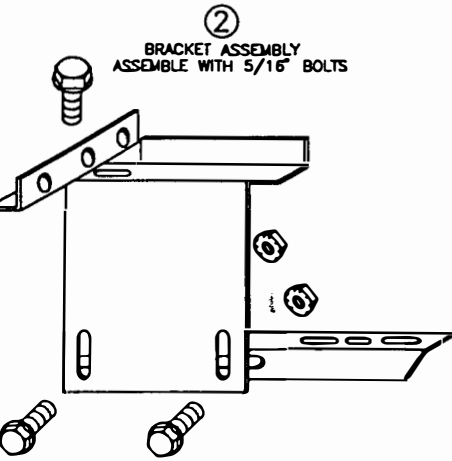

BRACKET ASSEMBLY ASSEMBLE WITH 5/16" BOLTS

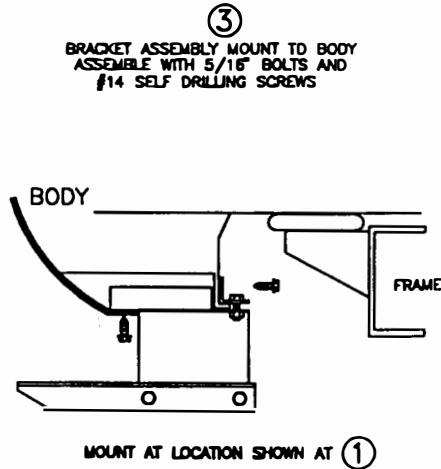

BRACKET ASSEMBLY MOUNT TO BODY ASSEMBLY WITH 5/16" BOLTS AND #14 SELF DRILLING SCREWS

MOUNT AT LOCATION SHOWN AT ①

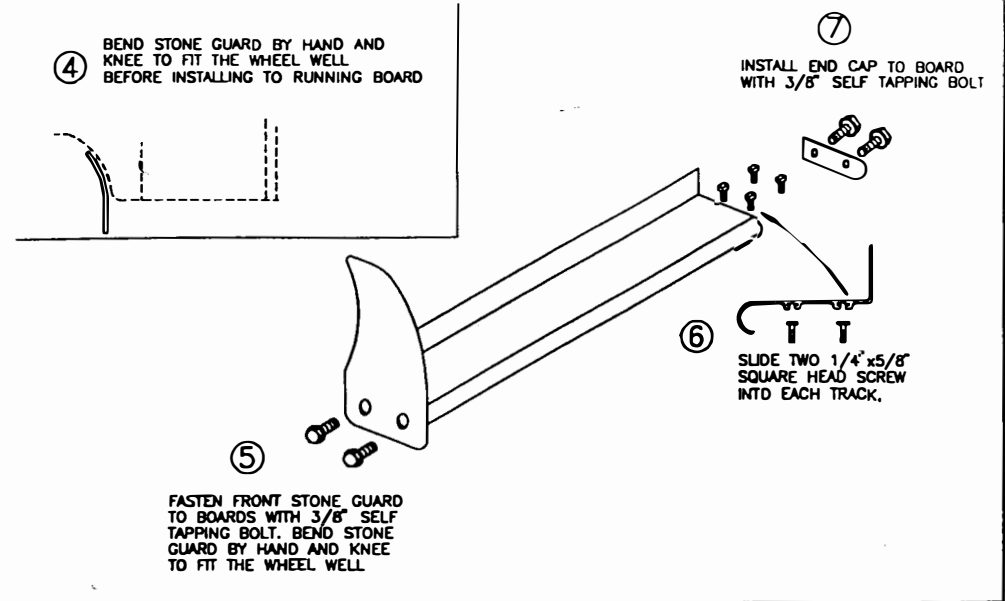

④ BEND STONE GUARD BY HAND AND KNEE TO FIT THE WHEEL WELL BEFORE INSTALLING TO RUNNING BOARD

⑦ INSTALL END CAP TO BOARD WITH 3/8" SELF TAPPING BOLT

⑤ FASTEN FRONT STONE GUARD TO BOARDS WITH 3/8" SELF TAPPING BOLT. BEND STONE GUARD BY HAND AND KNEE TO FIT THE WHEEL WELL

⑥ SLIDE TWO 1/4" x 5/8" SQUARE HEAD SCREW INTO EACH TRACK.

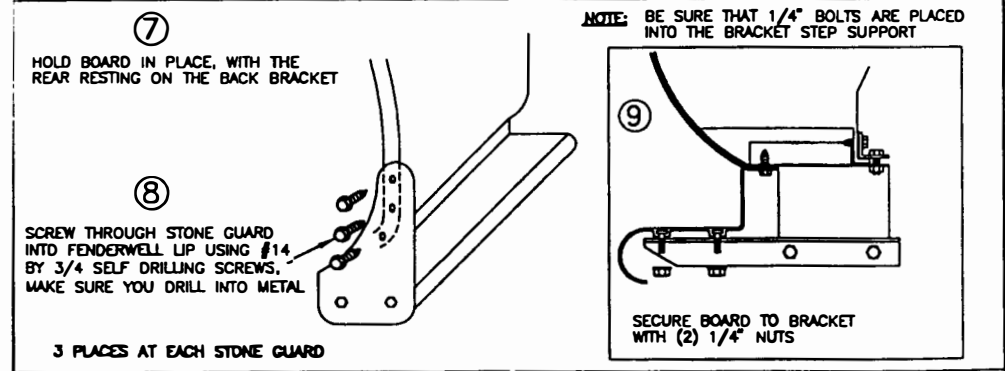

⑦ HOLD BOARD IN PLACE, WITH THE REAR RESTING ON THE BACK BRACKET

NOTE: BE SURE THAT 1/4" BOLTS ARE PLACED INTO THE BRACKET STEP SUPPORT

⑧ SCREW THROUGH STONE GUARD INTO FENDERWELL LIP USING #14 BY 3/4 SELF DRILLING SCREWS. MAKE SURE YOU DRILL INTO METAL

3 PLACES AT EACH STONE GUARD

⑨ SECURE BOARD TO BRACKET WITH (2) 1/4" NUTS

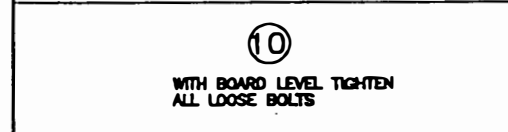

⑩ WITH BOARD LEVEL TIGHTEN ALL LOOSE BOLTS

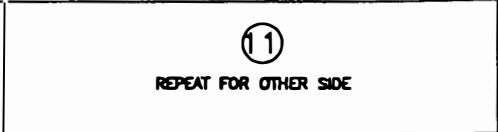

⑪ REPEAT FOR OTHER SIDE

INSTALLATION PARTS LIST:

QTY.	DESCRIPTION
1	RUNNING BOARD 1 DRIVER & 1 PASSENGER
1	STONE GUARD 1 LEFT & 1 RIGHT
8	3/8" x 1 SELF TAPPING SCREW
14	#14 x 3/4" TEK SCREW
8	1/4" x 5/8" SQUARE HEAD SCREW
8	1/4"-20 HEX NUT

QTY.	DESCRIPTION
1	END CAP 1 LEFT & 1 RIGHT
4	HORIZONTAL BRACKET, SUPPORT, 3124F
10	5/16" x 3/4" BOLT
10	5/16-18 HEX WASHER HEAD NUT
4	FLAT BRACKET, FL20-2" OR FL21-4"
2	6" HORIZONTAL BRACKET, BT07

IN-43
03/19/01