

OWENS 88-98 CHEVY/GMC CREW CAB

DRILLING INTO BODY AND FRAME IS REQUIRED.

INSTALLATION PARTS LIST:	QTY	DESCRIPTION	QTY	DESCRIPTION
1	1	RUNNING BOARD 1 DRIVER & 1 PASSENGER	16	5/16" x 3/4" BOLT
2	1	STONE GUARD 1 LEFT & 1 RIGHT	16	5/16-18 HEX WASHER HEAD NUT
3	8	3/8"x1 SELF TAPPING SCREW	4	FLAT BRACKET, FL90
4	12	#14x3/4" SHEET METAL SCREW	4	BENT TAB, BT39
5	8	1/4"x5/8" SQUARE HEAD SCREW	4	HORIZONTAL BRACKET, SUPPORT, 3124F
6	8	1/4"-20 HEX NUT	1	END CAP 1 LEFT & 1 RIGHT

TOOLS REQUIRED: 5/16" DRILL • 1/2" HEX SOCKET • 1/2" WRENCH • 5/16" NUT DRIVER • 3/8" NUT DRIVER

MEASURE FROM FRONT WHEEL WELL TO BRACKET LOCATION
MARK THIS DIMENSION ON THE PINCH WELD

(DRIVERS SIDE SHOWN)

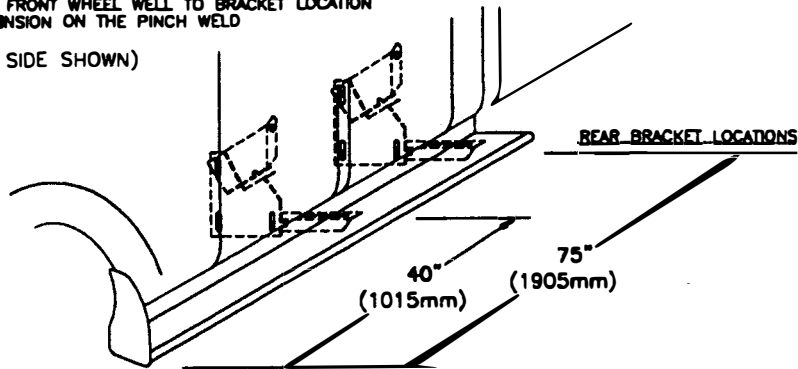

② BRACKET ASSEMBLY ASSEMBLE WITH 5/16" BOLTS LEAVE BOLTS LOOSE

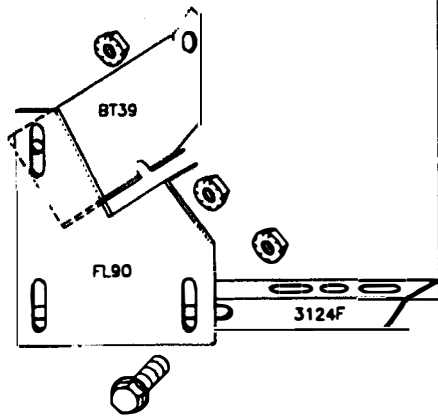

③ BRACKET ASSEMBLY MOUNT TO BODY ASSEMBLY WITH 5/16" BOLTS AND #14 SELF DRILLING TEX SCREWS

SLIDE BT39 AND FL90 OVER THE PINCH WELD FLANGE WITH BT39 UP AGAINST THE SIDE WALL BOLT TIGHT TO THE PINCH WELD. INSERT ONE #14x3/4" SELF DRILLING SCREW THROUGH FL90 INTO THE PINCH WELD AND BT39

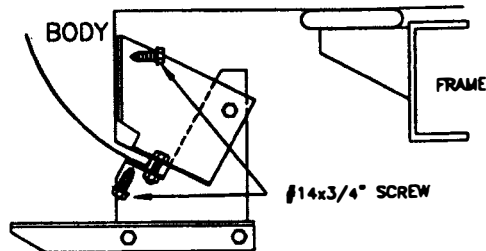

MOUNT AT LOCATION SHOWN AT ①

④ BEND STONE GUARD BY HAND AND KNEE TO FIT THE WHEEL WELL BEFORE INSTALLING TO RUNNING BOARD

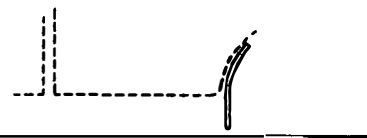

⑦

INSTALL END CAP TO BOARD WITH 3/8" SELF TAPPING BOLT.



⑥

SLIDE TWO 1/4"x5/8" SQUARE HEAD SCREW INTO EACH TRACK.

⑤ FASTEN FRONT STONE GUARD TO BOARDS WITH 3/8" SELF TAPPING BOLT. BEND STONE GUARD BY HAND AND KNEE TO FIT THE WHEEL WELL

⑧

HOLD BOARD IN PLACE, WITH THE REAR RESTING ON THE BACK BRACKET

NOTE:

BE SURE THAT 1/4" BOLTS ARE PLACED INTO THE BRACKET STEP SUPPORT

⑨

SCREW THROUGH STONE GUARD INTO FENDERWELL LIP USING #14 BY 3/4 SELF DRILLING SCREWS. MAKE SURE YOU DRILL INTO METAL.

3 PLACES AT EACH STONE GUARD

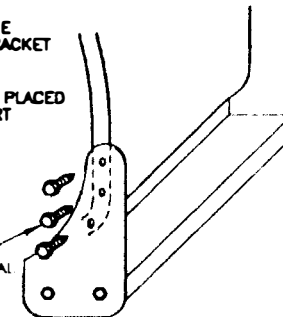

⑩

SECURE BOARD TO BRACKET WITH (2) 1/4" NUTS

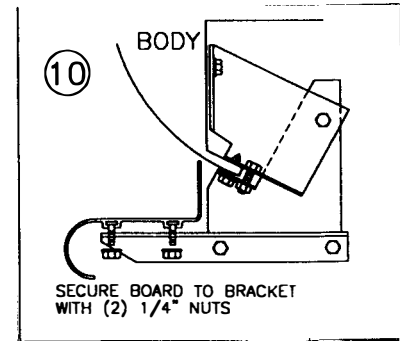

⑪

WITH BOARD LEVEL TIGHTEN ALL LOOSE BOLTS

⑫

REPEAT FOR OTHER SIDE