

98-CURRENT GMC H.D. EXTENDED CAB

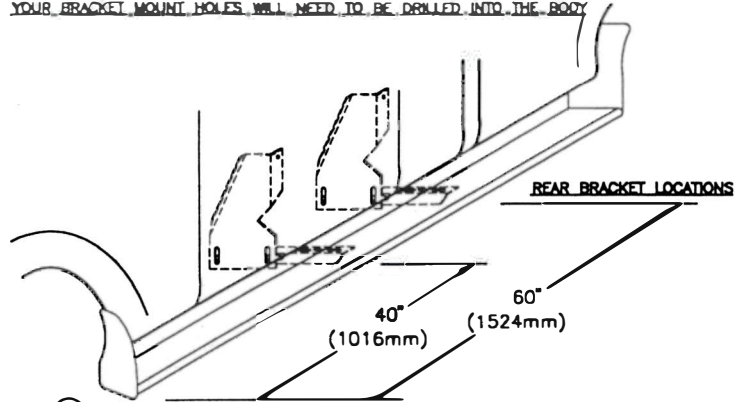

TOOLS REQUIRED: 5/16" DRILL • 1/2" HEX SOCKET • 1/2" WRENCH • 5/16" NUT DRIVER • 3/8" NUT DRIVER

YOUR BRACKET MOUNT HOLES WILL NEED TO BE DRILLED INTO THE BODY



① MEASURE FROM FRONT WHEEL WELL TO BRACKET LOCATIONS. MARK THIS DIMENSION ON THE PINCH WELD
(DRIVERS SIDE SHOWN)

② BRACKET ASSEMBLY ASSEMBLE WITH 5/16" BOLTS

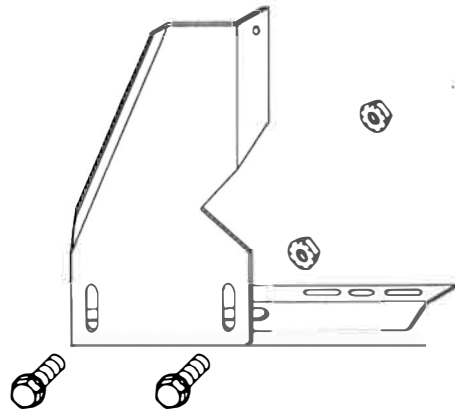

③ BRACKET ASSEMBLY MOUNT TO BODY ASSEMBLE WITH 5/16" BOLTS AND #14 SELF DRILLING TEK SCREW

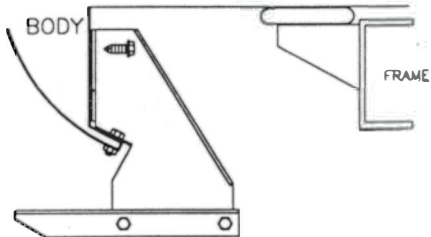

MOUNT AT LOCATION SHOWN AT ①

④ BEND STONE GUARD BY HAND AND KNEE TO FIT THE WHEEL WELL BEFORE INSTALLING TO RUNNING BOARD



INSTALL STONE GUARD TO OTHER END OF BOARD



⑥ SLIDE TWO 1/4"x5/8" SQUARE HEAD SCREW INTO EACH TRACK.

⑤ FASTEN FRONT STONE GUARD TO BOARDS WITH 3/8" SELF TAPPING BOLT. BEND STONE GUARD BY HAND AND KNEE TO FIT THE WHEEL WELL

⑦ HOLD BOARD IN PLACE, WITH THE REAR RESTING ON THE BACK BRACKET

NOTE:
BE SURE THAT 1/4" BOLTS ARE PLACED INTO THE BRACKET STEP SUPPORT

⑧ SCREW THROUGH STONE GUARD INTO FENDERWELL LIP USING #14 BY 3/4 SELF DRILLING SCREWS. MAKE SURE YOU DRILL INTO METAL

3 PLACES AT EACH STONE GUARD

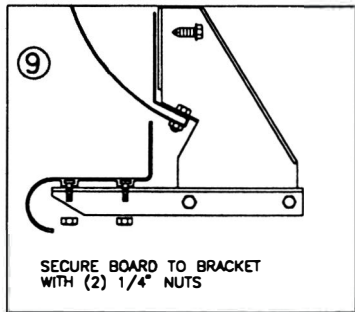

⑩ WITH BOARD LEVEL TIGHTEN ALL LOOSE BOLTS

⑪ REPEAT FOR OTHER SIDE

INSTALLATION PARTS LIST:

| QTY. | DESCRIPTION |
|------|--------------------------------------|
| 1 | RUNNING BOARD 1 DRIVER & 1 PASSENGER |
| 4 | STONE GUARD 2 LEFT & 2 RIGHT |
| 8 | 3/8"x1 SELF TAPPING SCREW |
| 16 | #14x3/4" TEK SCREW |
| 8 | 1/4x5/8" SQUARE HEAD SCREW |
| 8 | 1/4-20 HEX NUT |

| QTY. | DESCRIPTION |
|------|------------------------------------|
| 4 | HORIZONTAL BRACKET, SUPPORT, 3124F |
| 16 | 5/16"x 3/4" WASHER HEAD BOLT |
| 16 | 5/16" HEX WASHER HEAD NUT |
| 4 | FLAT BRACKET, FLD7 |