

98-CURRENT GMC H.D. CREW CAB

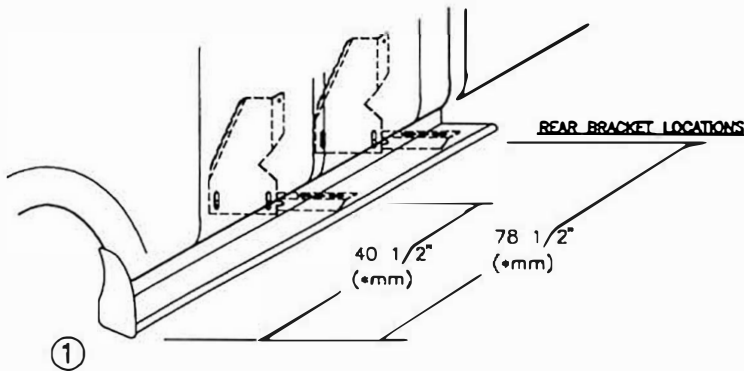

TOOLS REQUIRED: 5/16" DRILL • 1/2" HEX SOCKET • 1/2" WRENCH • 5/16" NUT DRIVER • 3/8" NUT DRIVER
 YOUR BRACKET MOUNT HOLES WILL NEED TO BE DRILLED INTO THE BODY



MEASURE FROM FRONT WHEEL WELL TO BRACKET LOCATIONS. MARK THIS DIMENSION ON THE PINCH WELD

(DRIVERS SIDE SHOWN)

BRACKET ASSEMBLY ASSEMBLE WITH 5/16" BOLTS

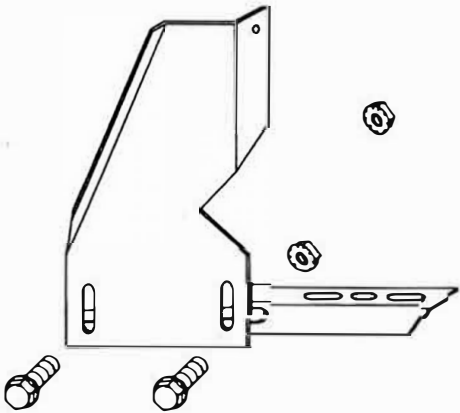

BRACKET ASSEMBLY MOUNT TO BODY ASSEMBLY WITH 5/16" BOLTS AND #14 SELF DRILLING TEK SCREW

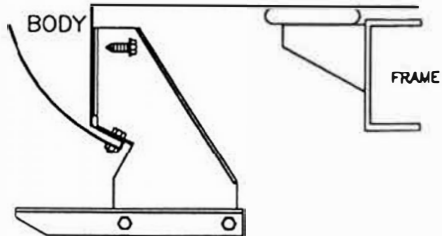

MOUNT AT LOCATION SHOWN AT 1

BEND STONE GUARD BY HAND AND KNEE TO FIT THE WHEEL WELL BEFORE INSTALLING TO RUNNING BOARD



INSTALL END CAP TO BOARD WITH 3/8" SELF TAPPING BOLT



SLIDE TWO 1/4"x5/8" SQUARE HEAD SCREW INTO EACH TRACK.

FASTEN FRONT STONE GUARD TO BOARDS WITH 3/8" SELF TAPPING BOLT. BEND STONE GUARD BY HAND AND KNEE TO FIT THE WHEEL WELL

HOLD BOARD IN PLACE, WITH THE REAR RESTING ON THE BACK BRACKET
 NOTE:
 BE SURE THAT 1/4" BOLTS ARE PLACED INTO THE BRACKET STEP SUPPORT

SCREW THROUGH STONE GUARD INTO FENDERWELL LIP USING #14 BY 3/4 SELF DRILLING SCREWS. MAKE SURE YOU DRILL INTO METAL

3 PLACES AT EACH STONE GUARD

SECURE BOARD TO BRACKET WITH (2) 1/4" NUTS

WITH BOARD LEVEL TIGHTEN ALL LOOSE BOLTS

REPEAT FOR OTHER SIDE

INSTALLATION PARTS LIST:

QTY.	DESCRIPTION
1	RUNNING BOARD 1 DRIVER & 1 PASSENGER
1	STONE GUARD 1 LEFT & 1 RIGHT
8	3/8"x1 SELF TAPPING SCREW
10	#14x3/4" TEK SCREW
8	1/4"x5/8" SQUARE HEAD SCREW
8	1/4"-20 HEX NUT

QTY. DESCRIPTION

1	END CAP 1 LEFT & 1 RIGHT
16	5/16"x 3/4" WASHER HEAD NUT
16	5/16-18 HEX WASHER HEAD NUT
4	FLAT BRACKET, FLO7
4	HORIZONTAL BRACKET, SUPPORT, 3124F