

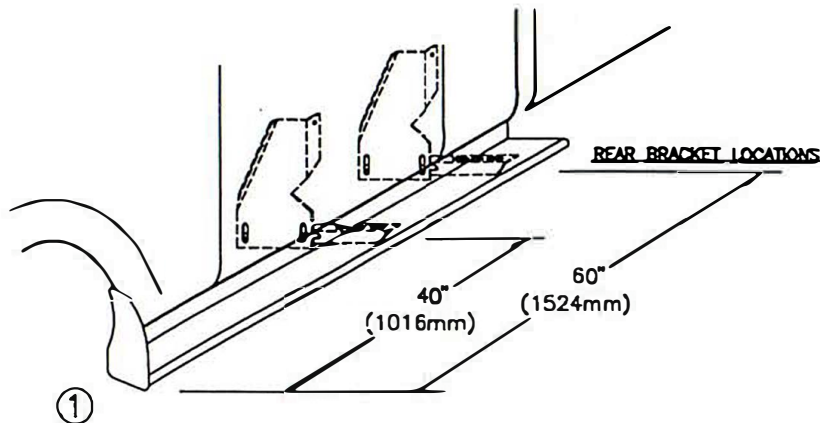

TOOLS REQUIRED: 5/16" DRILL • 1/2" HEX SOCKET • 1/2" WRENCH • 5/16" NUT DRIVER • 3/8" NUT DRIVER
YOUR BRACKET MOUNT HOLES WILL NEED TO BE DRILLED INTO THE BODY



① MEASURE FROM FRONT WHEEL WELL TO BRACKET LOCATIONS. MARK THIS DIMENSION ON THE PINCH WELD
 (DRIVERS SIDE SHOWN)

② BRACKET ASSEMBLY ASSEMBLE WITH 5/16" BOLTS

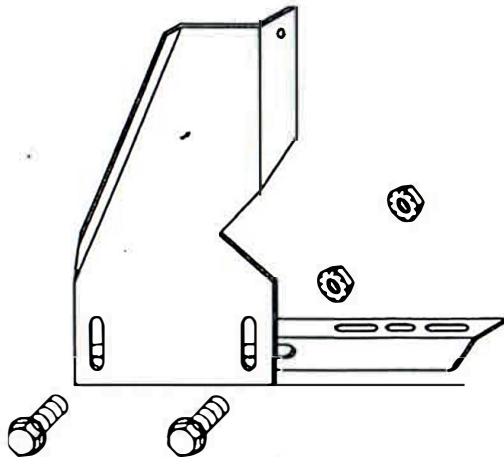

③ BRACKET ASSEMBLY MOUNT TO BODY ASSEMBLY WITH 5/16" BOLTS AND #14 SELF DRILLING TEK SCREW

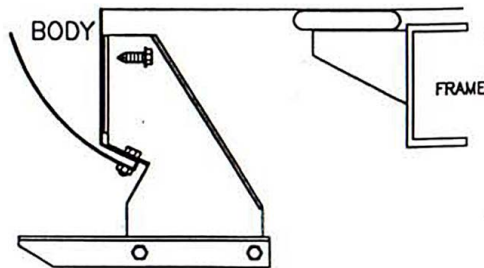

MOUNT AT LOCATION SHOWN AT ①

④ BEND STONE GUARD BY HAND AND KNEE TO FIT THE WHEEL WELL BEFORE INSTALLING TO RUNNING BOARD



⑤ FASTEN FRONT STONE GUARD TO BOARDS WITH 3/8" SELF TAPPING BOLT. BEND STONE GUARD BY HAND AND KNEE TO FIT THE WHEEL WELL.

⑤

⑦ INSTALL END CAP TO BOARD WITH 3/8" SELF TAPPING BOLT

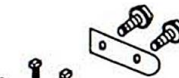

⑥ SLIDE TWO 1/4"x5/8" SQUARE HEAD SCREW INTO EACH TRACK.

⑥

⑦ HOLD BOARD IN PLACE, WITH THE REAR RESTING ON THE BACK BRACKET
NOTE:
 BE SURE THAT 1/4" BOLTS ARE PLACED INTO THE BRACKET STEP SUPPORT

⑧ SCREW THROUGH STONE GUARD INTO FENDERWELL LIP USING #14 BY 3/4" SELF DRILLING SCREWS. MAKE SURE YOU DRILL INTO METAL

3 PLACES AT EACH STONE GUARD

FRAME

⑩ WITH BOARD LEVEL TIGHTEN ALL LOOSE BOLTS

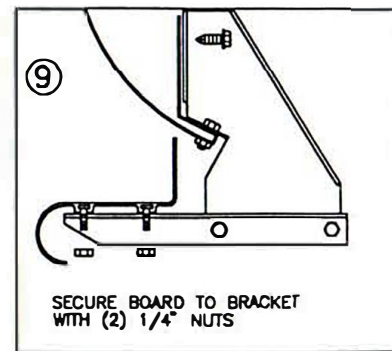

⑨ SECURE BOARD TO BRACKET WITH (2) 1/4" NUTS

⑪ REPEAT FOR OTHER SIDE

INSTALLATION PARTS LIST

QTY.	DESCRIPTION	QTY.	DESCRIPTION
1	RUNNING BOARD 1 DRIVER & 1 PASSENGER	1	END CAP 1 LEFT & 1 RIGHT
1	STONE GUARD 1 LEFT & 1 RIGHT	16	5/16"x 3/4" WASHER HEAD BOLT
8	3/8"x1 SELF TAPPING SCREW	16	5/16-18 HEX WASHER HEAD NUT
10	#14x3/4" TEK SCREW	4	FLAT BRACKET, FLO7
8	1/4x5/8" SQUARE HEAD SCREW	4	HORIZONTAL BRACKET, SUPPORT, 3124F
8	1/4-20 HEX NUT		