

# 94-CURRENT DODGE QUAD CAB

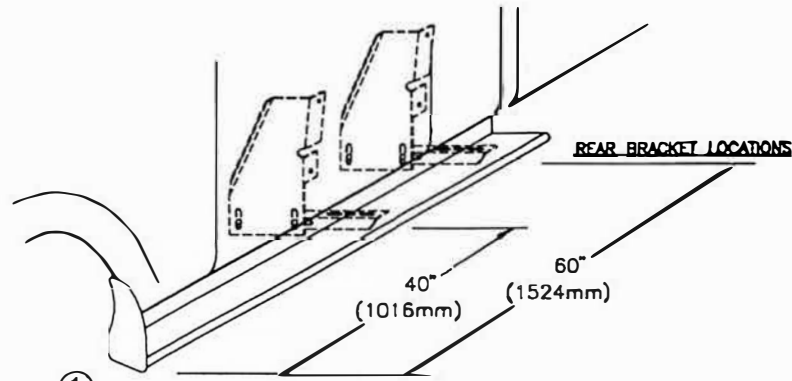

**TOOLS REQUIRED:** 5/16" DRILL • 1/2" HEX SOCKET • 1/2" WRENCH • 5/16" NUT DRIVER • 3/8" NUT DRIVER

**YOUR BRACKET MOUNT HOLES WILL NEED TO BE DRILLED INTO THE BODY**



①  
MEASURE FROM FRONT WHEEL WELL TO BRACKET LOCATIONS. MARK THIS DIMENSION ON THE PINCH WELD  
(DRIVERS SIDE SHOWN)

②  
BRACKET ASSEMBLY  
ASSEMBLE WITH 5/16" BOLTS

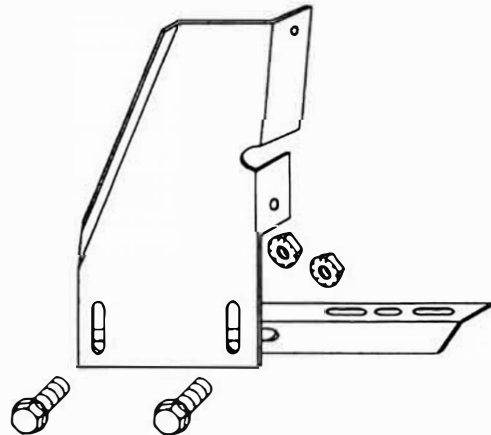

③  
BRACKET ASSEMBLY MOUNT TO BODY  
ASSEMBLE WITH 5/16" BOLTS AND  
#14 SELF DRILLING TEK SCREW

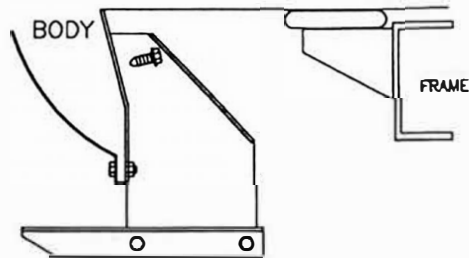

MOUNT AT LOCATION SHOWN AT ①

④  
BEND STONE GUARD BY HAND AND  
KNEE TO FIT THE WHEEL WELL  
BEFORE INSTALLING TO RUNNING BOARD



⑦  
INSTALL END CAP TO BOARD  
WITH 3/8" SELF TAPPING BOLT

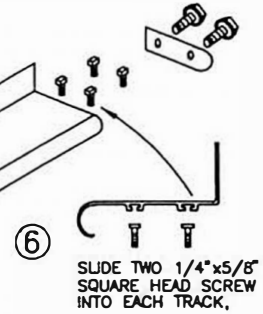

⑤  
FASTEN FRONT STONE GUARD  
TO BOARDS WITH 3/8" SELF  
TAPPING BOLT. BEND STONE  
GUARD BY HAND AND KNEE  
TO FIT THE WHEEL WELL

⑦  
HOLD BOARD IN PLACE, WITH THE  
REAR RESTING ON THE BACK BRACKET  
**NOTE:**  
BE SURE THAT 1/4" BOLTS ARE PLACED  
INTO THE BRACKET STEP SUPPORT

⑧  
SCREW THROUGH STONE GUARD  
INTO FENDERWELL LIP USING #14  
BY 3/4 SELF DRILLING SCREWS,  
MAKE SURE YOU DRILL INTO METAL

3 PLACES AT EACH STONE GUARD

⑩  
WITH BOARD LEVEL TIGHTEN  
ALL LOOSE BOLTS

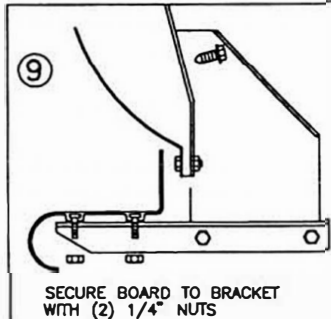

⑪  
REPEAT FOR OTHER SIDE

**INSTALLATION  
PARTS LIST:**

QTY.	DESCRIPTION
1	RUNNING BOARD 1 DRIVER & 1 PASSENGER
1	STONE GUARD 1 LEFT & 1 RIGHT
8	3/8" x 1 SELF TAPPING SCREW
10	#14 x 3/4" TEK SCREW
8	1/4 x 5/8" SQUARE HEAD SCREW
8	1/4-20 HEX NUT

QTY.	DESCRIPTION
1	END CAP 1 LEFT & 1 RIGHT
16	5/16" x 3/4" WASHER HEAD BOLT
16	5/16-18 HEX WASHER HEAD NUT
4	HORIZONTAL BRACKET, SUPPORT, 3124F
4	FLAT BRACKET, FLO9 2" RISER
4	FLAT BRACKET, FL15 4" RISER

IN-19  
02/07/01