

87-96 F-150 EXTENDED CAB

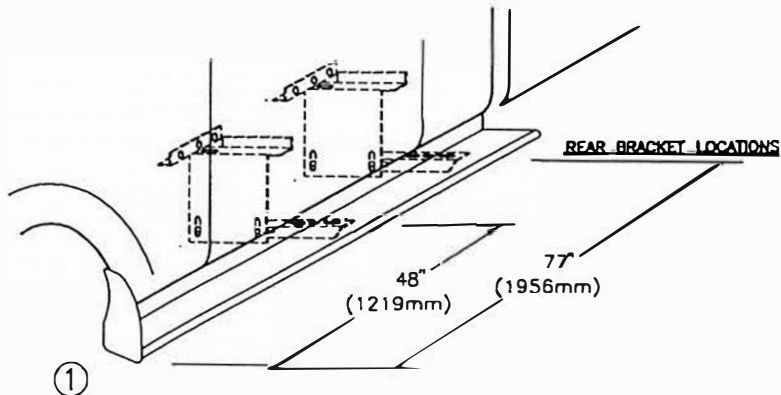

TOOLS REQUIRED: 5/16" DRILL • 1/2" HEX SOCKET • 1/2" WRENCH • 5/16" NUT DRIVER • 3/8" NUT DRIVER
YOUR BRACKETS INSTALL IN FACTORY HOLES



MEASURE FROM FRONT WHEEL WELL TO BRACKET LOCATIONS. MARK THIS DIMENSION ON THE PINCH WELD (DRIVERS SIDE SHOWN)

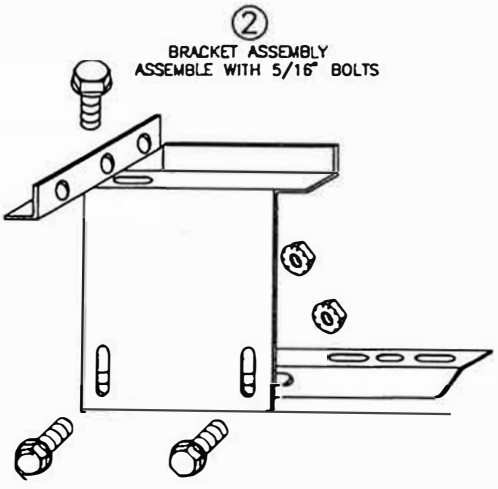

BRACKET ASSEMBLY ASSEMBLE WITH 5/16" BOLTS

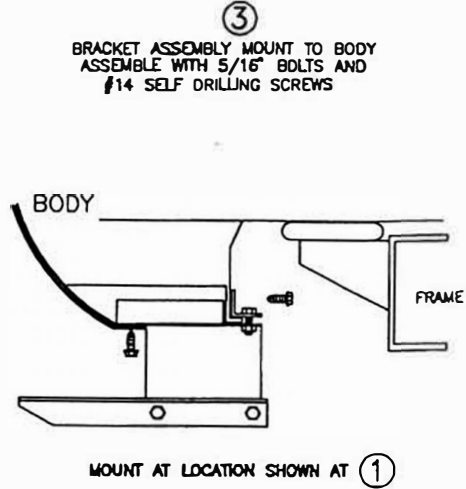

BRACKET ASSEMBLY MOUNT TO BODY ASSEMBLE WITH 5/16" BOLTS AND #14 SELF DRILLING SCREWS

MOUNT AT LOCATION SHOWN AT 1

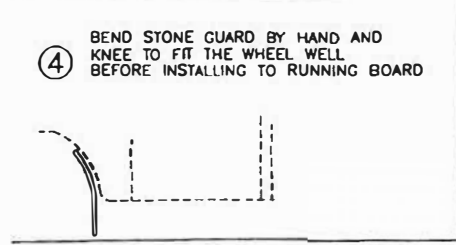

BEND STONE GUARD BY HAND AND KNEE TO FIT THE WHEEL WELL BEFORE INSTALLING TO RUNNING BOARD

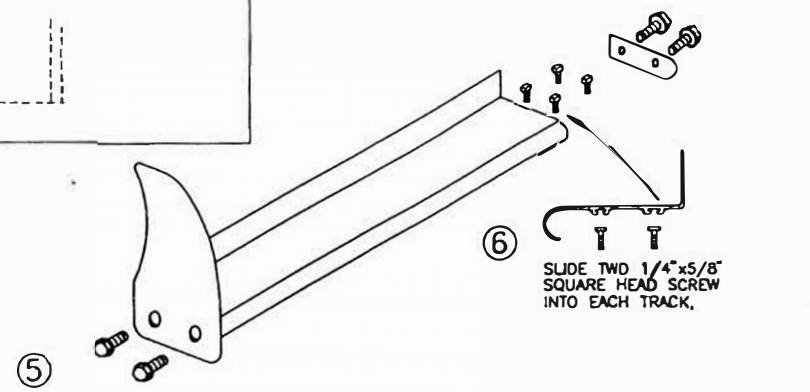

FASTEN FRONT STONE GUARD TO BOARDS WITH 3/8" SELF TAPPING BOLT. BEND STONE GUARD BY HAND AND KNEE TO FIT THE WHEEL WELL.

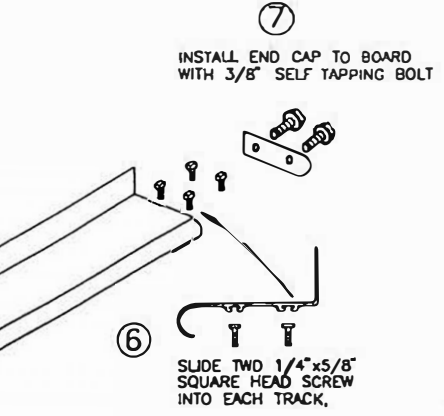

SLIDE TWO 1/4"x5/8" SQUARE HEAD SCREW INTO EACH TRACK.

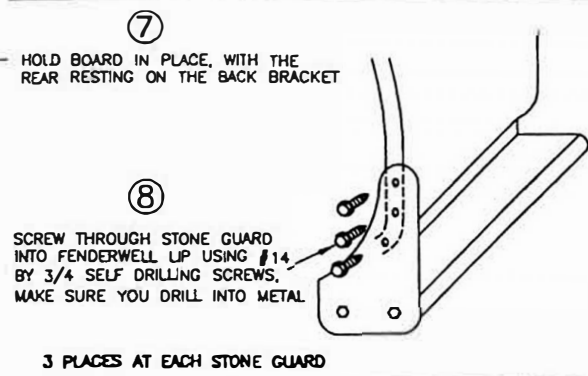

HOLD BOARD IN PLACE, WITH THE REAR RESTING ON THE BACK BRACKET

SCREW THROUGH STONE GUARD INTO FENDERWELL LIP USING #14 BY 3/4 SELF DRILLING SCREWS. MAKE SURE YOU DRILL INTO METAL.

3 PLACES AT EACH STONE GUARD

NOTE: BE SURE THAT 1/4" BOLTS ARE PLACED INTO THE BRACKET STEP SUPPORT

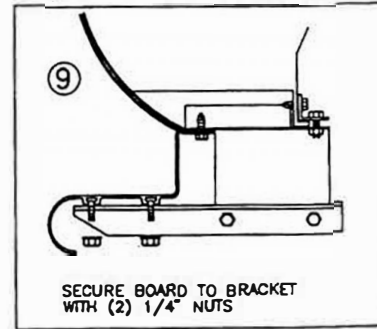

SECURE BOARD TO BRACKET WITH (2) 1/4" NUTS

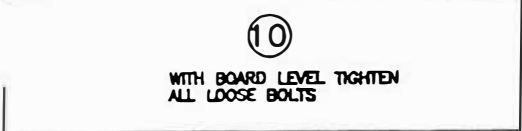

WITH BOARD LEVEL TIGHTEN ALL LOOSE BOLTS

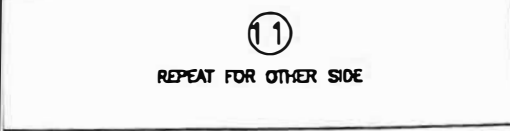

REPEAT FOR OTHER SIDE

INSTALLATION PARTS LIST

QTY.	DESCRIPTION
1	RUNNING BOARD 1 DRIVER & 1 PASSENGER
1	STONE GUARD 1 LEFT & 1 RIGHT
8	3/8"x1 SELF TAPPING SCREW
14	#14x3/4" TEK SCREW
8	1/4"x5/8" SQUARE HEAD SCREW
8	1/4"-20 HEX NUT

QTY. DESCRIPTION

1	END CAP 1 LEFT & 1 RIGHT
4	HORIZONTAL BRACKET, SUPPORT, 3124F
10	5/16"x 3/4" BOLT
10	5/16-18 HEX WASHER HEAD NUT
4	FLAT BRACKET, FL20-2" OR FL21-4"
2	6" HORIZONTAL BRACKET, BT07