

TOOLS REQUIRED: 5/16" DRILL * 1/2" HEX SOCKET * 1/2" WRENCH * 5/16" NUT DRIVER * 3/8" NUT DRIVER

YOUR BRACKETS INSTALL IN FACTORY HOLES

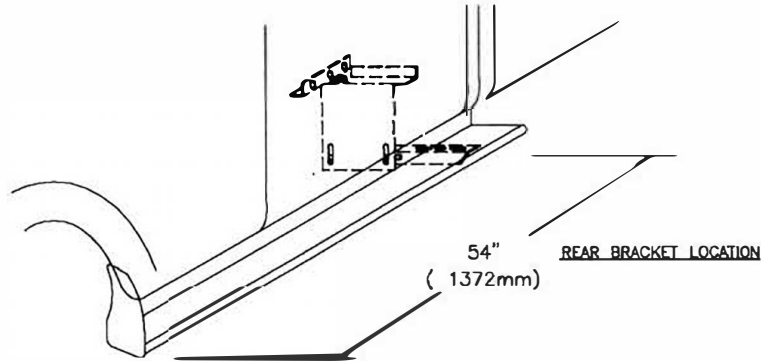

① MEASURE FROM FRONT WHEEL WELL TO BRACKET LOCATION
MARK THIS DIMENSION ON THE PINCH WELD
(DRIVERS SIDE SHOWN)

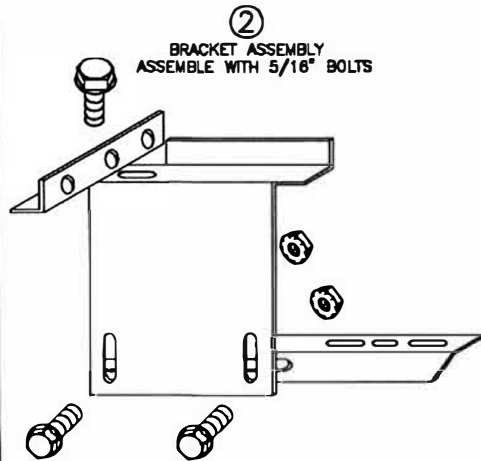

② BRACKET ASSEMBLY
ASSEMBLE WITH 5/16" BOLTS

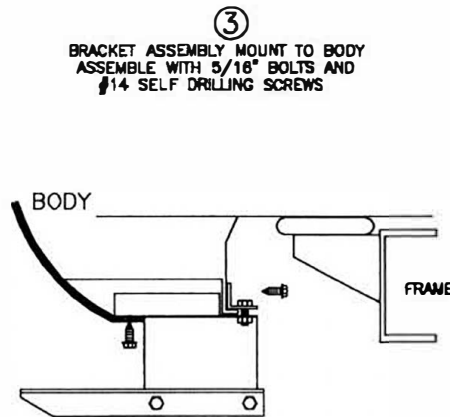

③ BRACKET ASSEMBLY MOUNT TO BODY
ASSEMBLE WITH 5/16" BOLTS AND
#14 SELF DRILLING SCREWS

MOUNT AT LOCATION SHOWN AT ①

④ BEND STONE GUARD BY HAND AND
KNEE TO FIT THE WHEEL WELL
BEFORE INSTALLING TO RUNNING BOARD



⑤ FASTEN FRONT STONE GUARD
TO BOARDS WITH 3/8" SELF
TAPPING BOLT. BEND STONE
GUARD BY HAND AND KNEE
TO FIT THE WHEEL WELL

⑦ INSTALL END CAP TO BOARD
WITH 3/8" SELF TAPPING BOLT

⑥ SLIDE ONE 1/4"x5/8"
SQUARE HEAD SCREW
INTO EACH TRACK.

⑦ HOLD BOARD IN PLACE, WITH THE
REAR RESTING ON THE BACK BRACKET

⑧ SCREW THROUGH STONE GUARD
INTO FENDERWELL LIP USING #14
BY 3/4 SELF DRILLING SCREWS.
MAKE SURE YOU DRILL INTO METAL

3 PLACES AT EACH STONE GUARD

NOTE: BE SURE THAT 1/4" BOLTS ARE PLACED
INTO THE BRACKET STEP SUPPORT

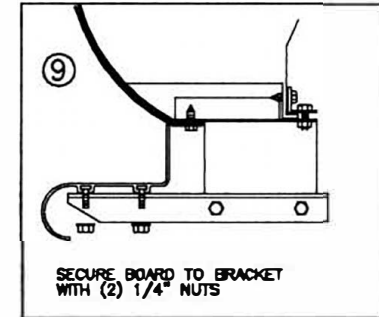

⑨ SECURE BOARD TO BRACKET
WITH (2) 1/4" NUTS

⑩ WITH BOARD LEVEL TIGHTEN
ALL LOOSE BOLTS

⑪ REPEAT FOR OTHER SIDE

INSTALLATION PARTS LIST:	QTY.	DESCRIPTION
	1	RUNNING BOARD 1 DRIVER & 1 PASSENGER
	1	STONE GUARD 1 LEFT & 1 RIGHT
	8	3/8"x1 SELF TAPPING SCREW
	10	#14x3/4" TEK SCREW
	4	1/4x5/8" SQUARE HEAD SCREW
	4	1/4-20 HEX NUT

QTY.	DESCRIPTION
1	END CAP 1 LEFT & 1 RIGHT
2	HORIZONTAL BRACKET, SUPPORT, 3124F
6	5/16"x 3/4" BOLT
6	5/16-18 HEX WASHER HEAD NUT
2	FLAT BRACKET, FL20-2" OR FL21-4"
2	6" HORIZONTAL BRACKET, BT07