

Installation Instructions Kia Sedona • Hyundai Entourage Product No.

2006 to Current Kia Sedona
2007 to Current Hyundai Entourage

2181

		Qty.	Description	Qty.	Description
Installation Parts List:	A	2	GlaSteps #2181-D&P (Driver & Passenger)	F	4 Flat Plates #FL112
	B	2	Foam Tape Strips	G	8 Step Supports #3124F
	C	2	Step Pads	H	20 5/16" x 3/4" Washer Head Bolts
	D	4	Flat Plates #FL111	I	20 5/16" Washer Head Nuts
	E	4	Bent Tabs #AS01	J	#14 x 3/4" Self-Drilling Screws (short)

Note: There may be extra hardware included that is not used.

Tools Required: 5/16" Drill • 1/2" Hex Socket • 1/2" Wrench • 5/16" Nut Driver • 3/8" Nut Driver

- Prior to painting, fit your GlaSteps to the body.** A good fit is accomplished when mating surfaces fit with minimum light gaps. Note: Vehicle bodies have variations and a perfect fit may not be possible.
- Painting your GlaSteps.** To insure a proper paint finish, use a top quality auto paint system and follow the manufacturers instructions. Your GlaSteps should be sanded and primed before painting.

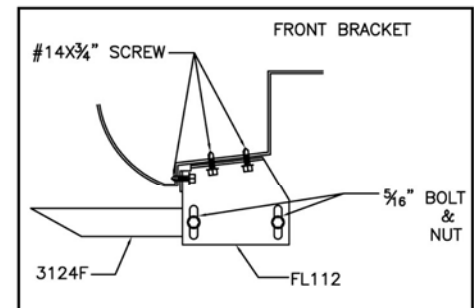
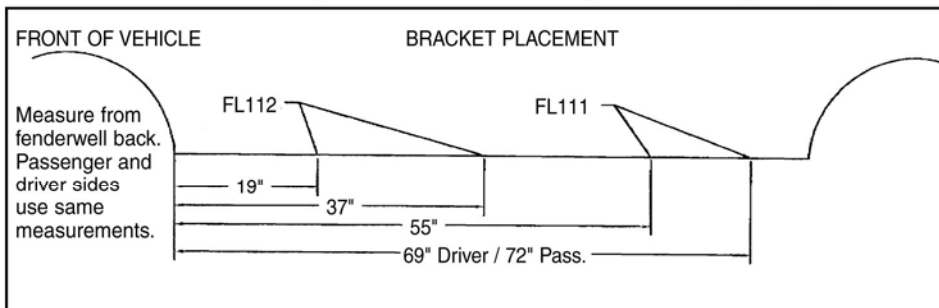

- Measure from front wheel well, back to dimensions shown above. Mark these bracket location centers. Note: Steel plates have been inserted under fiberglass to mount brackets. Double check your marks to be sure they line up with the steel plates before drilling.

- Attach FL112 to marked locations using #14 x 3/4" self-drilling screws into the pinch weld and the rocker panel.

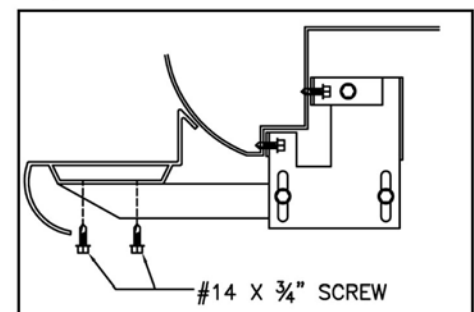
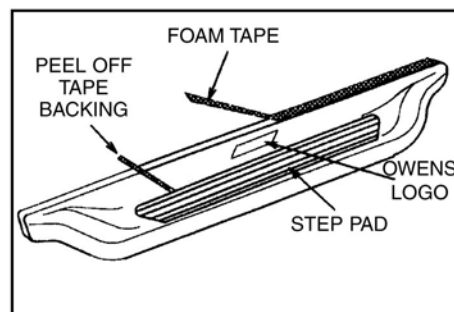
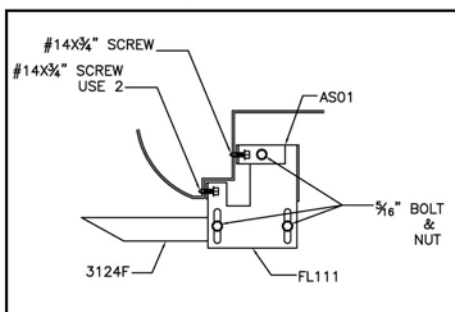

- Bolt AS01 to FL111, just lightly tighten. Place flat bracket FL111 at the pinch weld locations shown above. Use 2 #14 x 3/4" self-drilling screws to attach the flat bracket to the pinch weld. Use another self drilling screw to attach the AS01 bent tab to the rocker panel. Tighten the 5/16" nut and bolt holding the bent tab to the flat bracket.
- Clean surface prior to attaching tape and step pads with denatured alcohol. Apply foam tape to top lip of board. Position step pad on stepping surface. Peel off tape backing starting with rear strip. Keep pad in position, peel off backing then apply pressure to top of pad to stick tape to board. Continue above steps for all tape strips.
- Position step on brackets. When proper placement is achieved, use #14 x 3/4" self-drilling screws to attach to brackets. Use 2 screws per bracket.
- Make sure your GlaSteps are level, tighten all bolts to 18 foot pounds. Do not overtighten the sheet metal screws to prevent holes from being stripped out.