

Installation Guide

Chevy/GMC Full Size Van

Product No.

2003 to Current

135" Wheelbase

2153

Note: Drilling into body is required.

Installation Parts List:	Qty.	Description	Qty.	Description
A	2	<u>Running Boards</u>	G	Bent Tabs #BT41
B	2	Foam Tape Strips	H	Bent Tabs #BT42
C	2	Step Pads	I	5/16" x 3/4" Washer Head Bolts
D	6	Flat Brackets #FL76	J	5/16" Washer Head Nuts
E	6	Step Supports #3124F	K	#14 x 3/4" Self-Drilling Screws
F	6	Bent Tabs #BT40	L	#12 x 1-1/4" Self-Drilling Screws with Rubber Washers

Tools Required: 5/16" Drill • 1/2" Hex Socket • 1/2" Wrench • 5/16" Nut Driver • 3/8" Nut Driver

- Prior to painting, fit your GlaSteps to the body.** A good fit is accomplished when mating surfaces fit with minimum light gaps. Note: Vehicle bodies have variations and a perfect fit may not be possible.
- Painting your GlaSteps.** To insure a proper paint finish, use a top quality auto paint system and follow the manufacturers instructions. Your GlaStep should be sanded and primed before painting.
- Measure** from front wheel well, back to dimensions shown in illustration at right. Mark these bracket location centers.

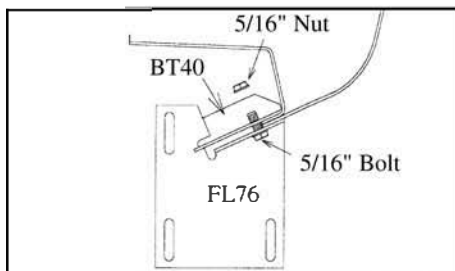
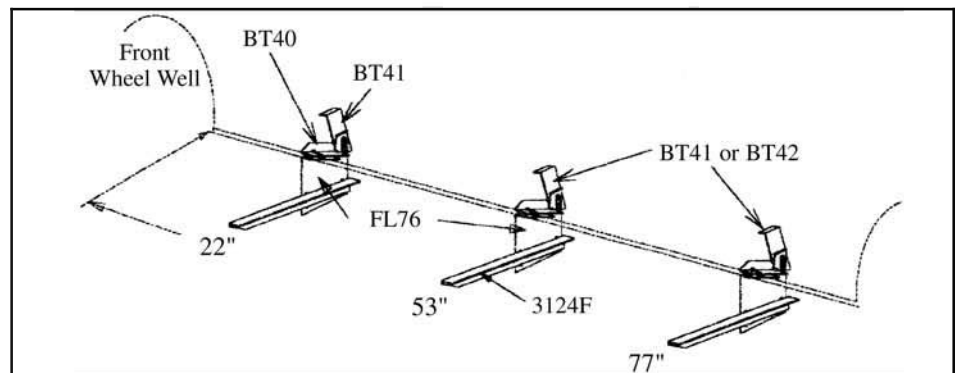

- Mate BT40 top clamp onto FL76 flat plate using 5/16" nuts and bolts. Clamp assembly onto pinch weld at marks.

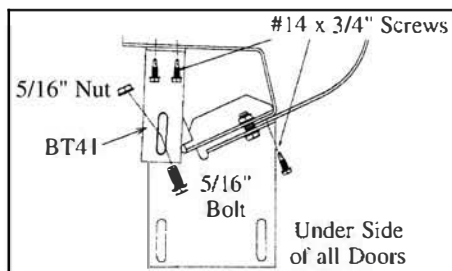

- 5A.** Attach BT41s to FL76s using 5/16" nuts and bolts. Mate top of BT41s to bottom of step areas. Screw BT41 to bottom of step area using two #14 screws, then screw through FL76 into pinch weld using one #14 screw. Snug 5/16" nut and bolt.

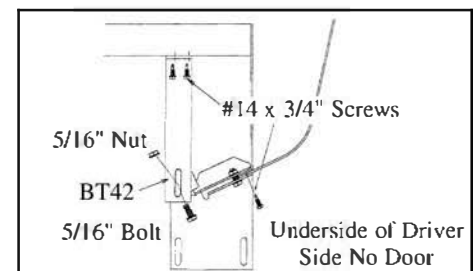

- 5B.** When no rear drivers door is present, use BT42s in place of BT41s.

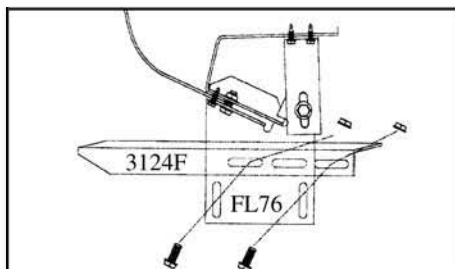

- Attach 3124F step supports to FL76 using two each 5/16" nuts and bolts. Snug with fingers but do not tighten at this time.

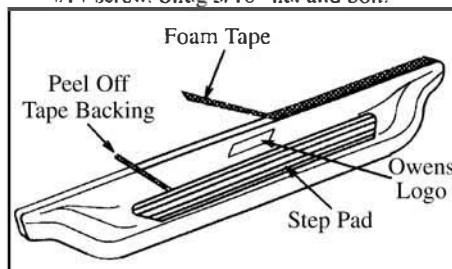

- Clean surface prior to attaching tape and step pads with denatured alcohol. Apply foam tape to top lip of board. Position step pad on stepping surface. Peel off tape backing starting with rear strip. Keep pad in position, peel off backing then apply pressure to top of pad to stick tape to board. Continue above steps for all tape strips.

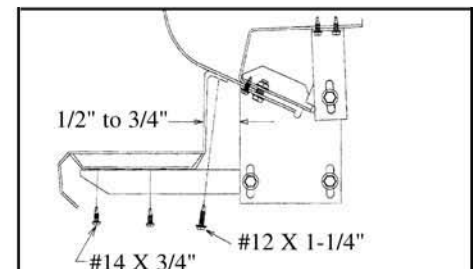

- Position step on brackets. Align back of step upper lip approximately 1-1/2" out from edge of pinch weld. Use #12 x 3/4" screw through lip. (Note: If installing box boards, align both before securing steps to body.) Next, attach step to 3124F using two #14 x 3/4" screws. Adjust brackets and **tighten all bolts to 18 foot pounds.**