

Installation Guide

All Dodge & Chrysler Mini Vans

Product No.

1996 to Current

With Easy Out Roller Seats®

2128

Note: Drilling into body is required.

2129

| Installation Parts List: | | Qty. | Description | Qty. | Description |
|--------------------------|---|-------------------------------|-------------|------|--|
| A | 2 | GlaSteps (Driver & Passenger) | G | 6 | Step Supports #3124F |
| B | 2 | Foam Tape Strips | H | 2 | 5/16" Washers |
| C | 2 | Step Pads | I | 28 | 5/16" x 3/4" Washer Head Bolts |
| D | 4 | Flat Brackets #FL63 | J | 28 | 5/16" Washer Head Nuts |
| E | 2 | Flat Brackets #FL71Rear | K | 8 | #12 x 1-1/4" Self-Drilling Screws w/Rubber Washers |
| F | 2 | Bent Tabs #BT37 | L | 12 | #14 x 3/4" Self-Drilling Screws |

Tools Required:

5/16" Drill • 1/2" Hex Socket • 1/2" Wrench • 5/16" Nut Driver • 3/8" Nut Driver

- Prior to painting, fit your GlaSteps to the body.** A good fit is accomplished when mating surfaces fit with minimum light gaps. Note: Vehicle bodies have variations and a perfect fit may not be possible.
- Painting your GlaSteps.** To insure a proper paint finish, use a top quality auto paint system and follow the manufacturers instructions. Your GlaStep should be sanded and primed before painting.

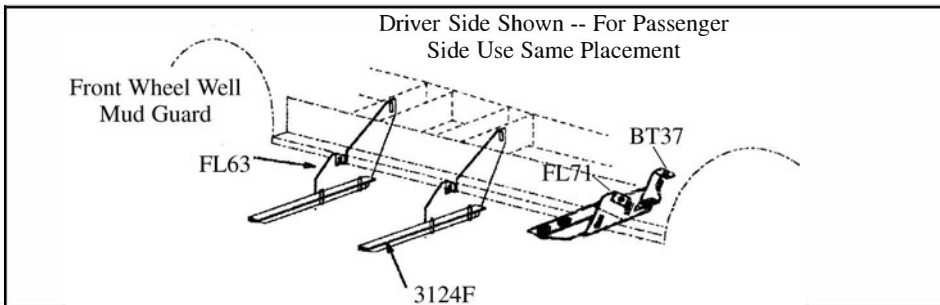

- Steel plates have been inserted under fiberglass to mount brackets securely using self-drilling screws. See illustration at right. Follow instruction steps #5 and #6 for bracket locations.

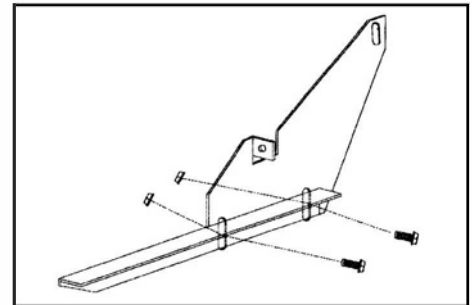

- Assemble FL63 flat bracket to 3124F step support using two 5/16" nuts and bolts. **Do not tighten at this time.**

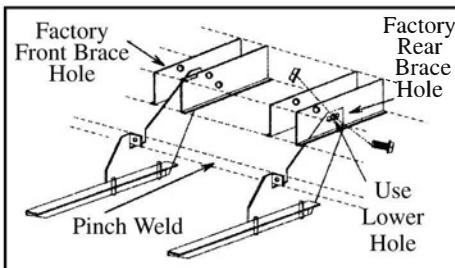

- Mount FL63s to front and rear frame braces using 5/16" nuts and bolts through factory brace holes. Mount to back of forward most brace, and to front of rear most brace. **Do not tighten bolts at this time.**

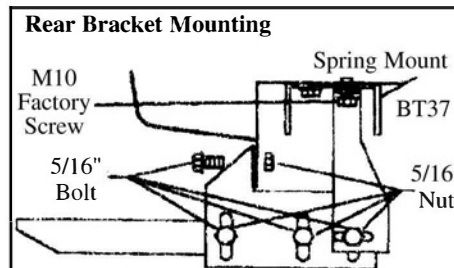

- Remove the front inside spring mount M10 bolt, reinstall mounting the BT37 bent tab. Use a 5/16" bolt and nut to attach to flat bracket FL71. Drill a 5/16" hole through the bracket and into the pinch weld. Secure with a 5/16" bolt and nut.

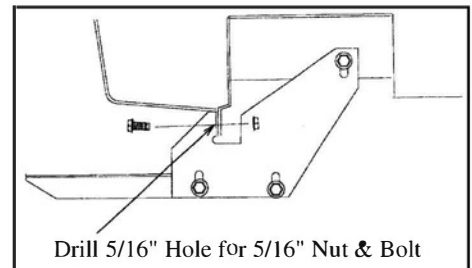

- Pull flat brackets up tight to body. Drill 5/16" diameter hole using bracket hole as a guide, then through pinch weld. Secure with 5/16" nut and bolt.

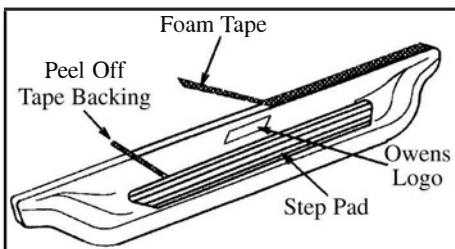

- Clean surface prior to attaching tape and step pads with denatured alcohol. Apply foam tape to top lip of board. Position step pad on stepping surface. Peel off tape backing starting with rear strip. Keep pad in position, peel off backing then apply pressure to top of pad to stick tape to board. Continue above steps for all tape strips.

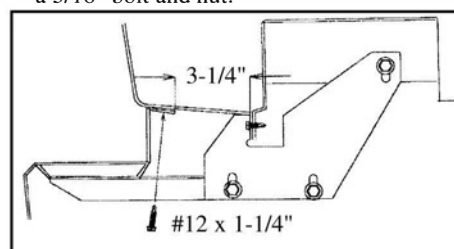

- Place GlaStep on brackets. Keep back lip of step about 3-1/4" from pinch weld, then use #12 x 1-1/4" self-drilling screws to attach to van body.

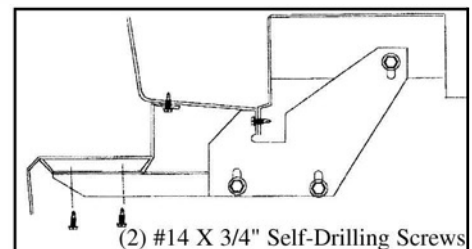

- Secure step support bracket to bottom of GlaStep using two #14 x 3/4" self-drilling screws per bracket. **Tighten all bolts to 18 foot pounds.**