

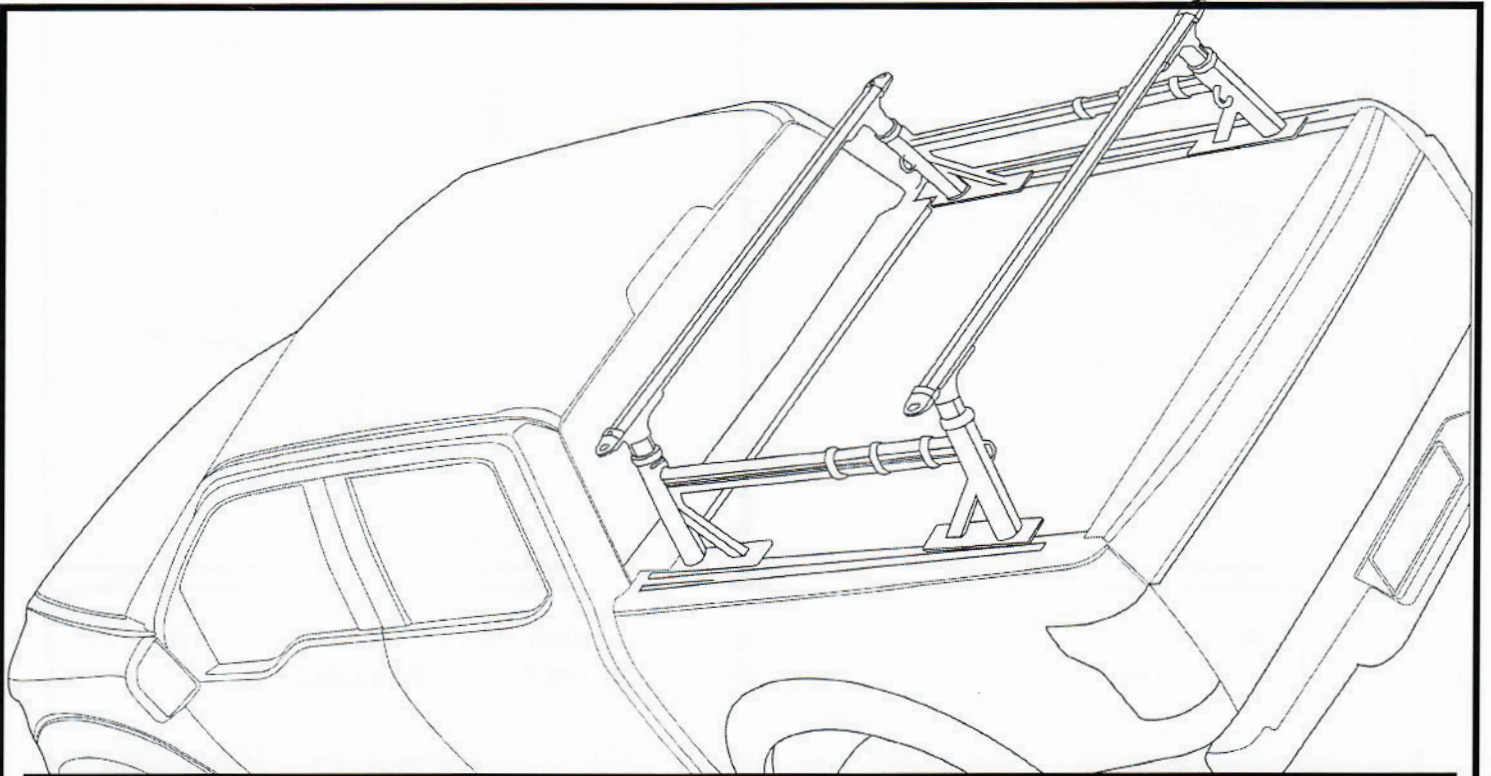

FROM/BED RACK

INSTRUCTIONS



Contents

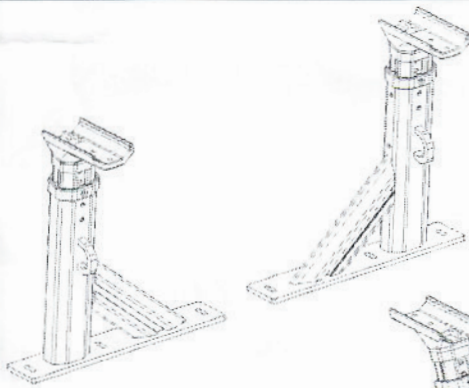

Main body(2x)

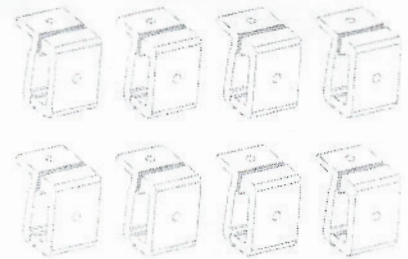

Cards(8x)

wrench(1x)

T45(1x)

T30(1x)

M6 Nuts (4x)

M8 Nuts (20x)

8*18-Screw (8x)

8*30-Screw(8x)

8*45-Screw(8x)

8*30-T screw(12x)

Cap nut (12x)

Plastic seal (4x)

6*50-screw (4x)

Spring pad (28x)

Flat pad (16x)

Large flat pad (12x)

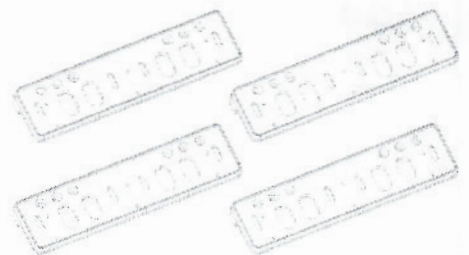

Base bracket(4x)

ROLL BAR WITH ROLL COVER

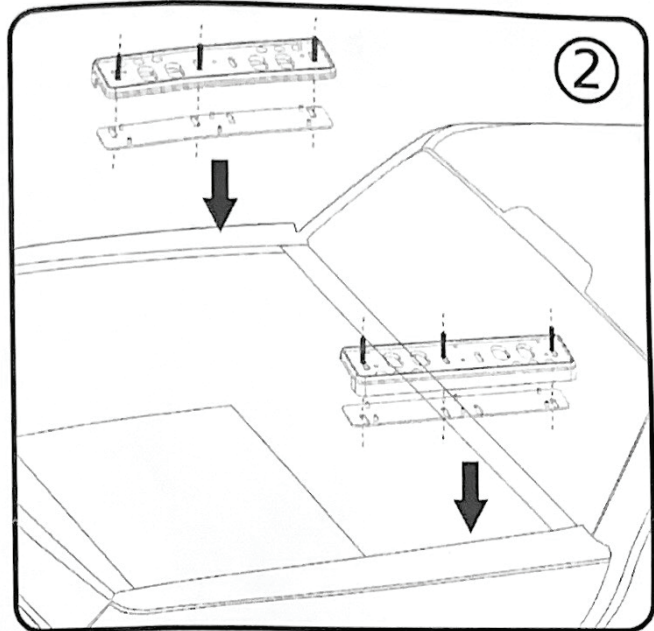
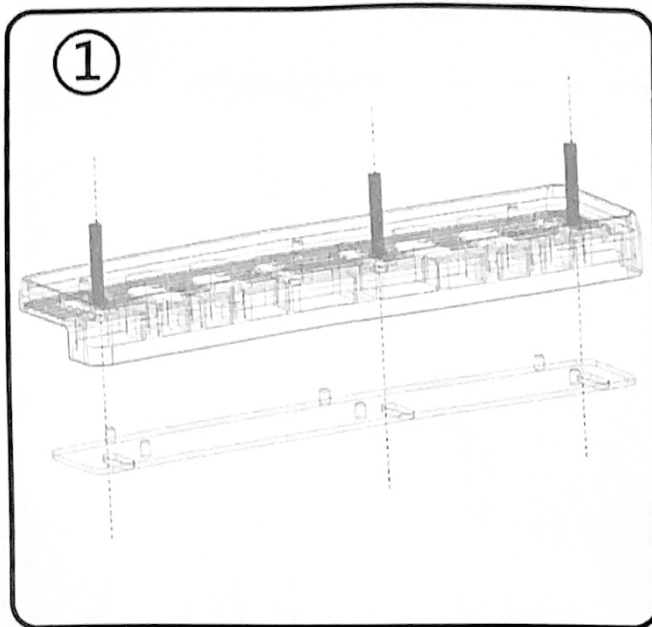

- ③ Slide the T-shaped screw into the groove, and then adjust the base to a suitable position on the car. The screw corresponds to the hole position, and then fixed and locked.

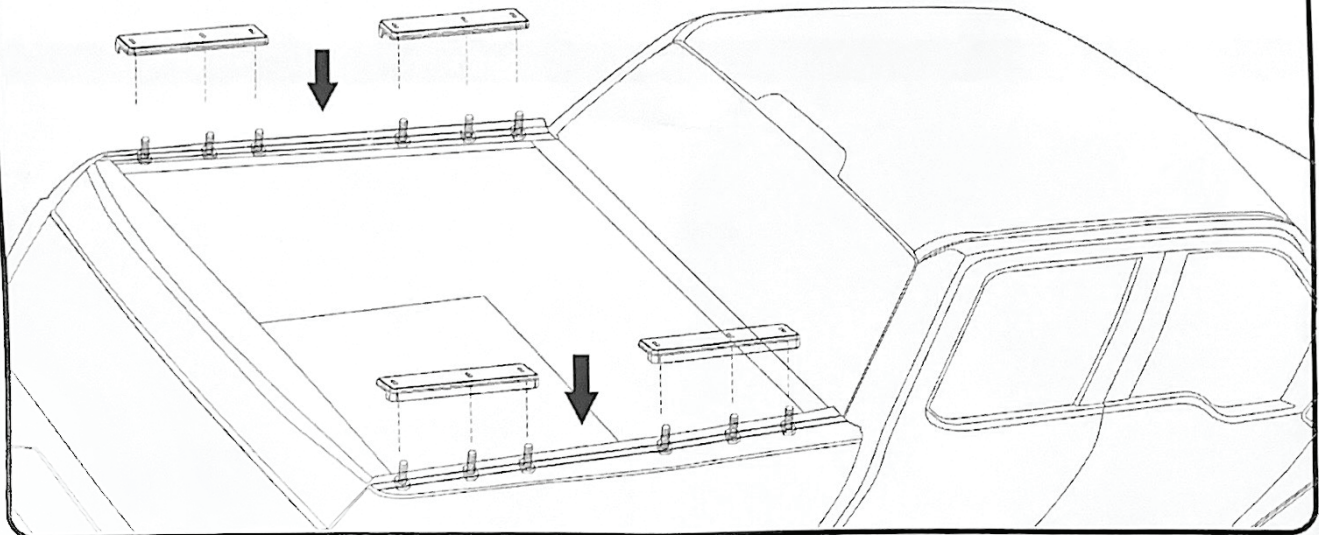

④

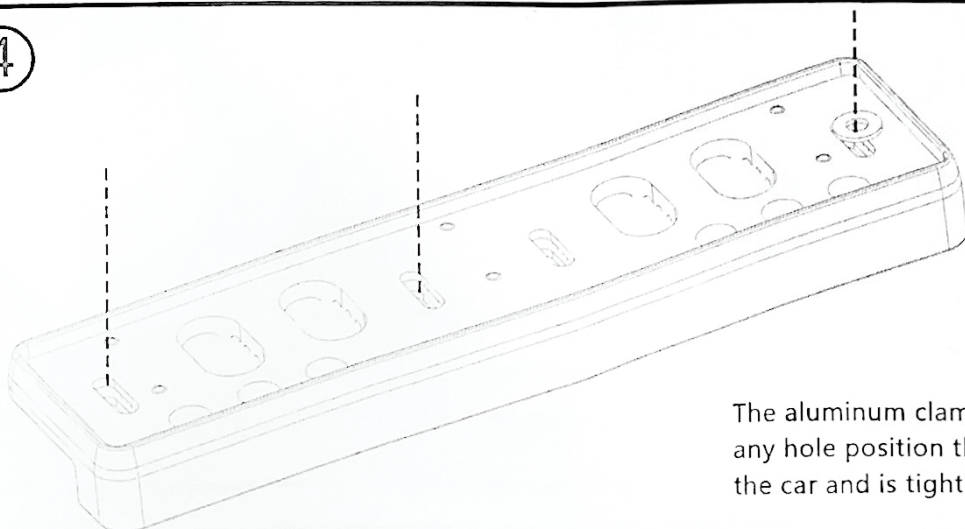

The aluminum clamp corresponds to any hole position that is suitable for the car and is tightly fixed.

ROLL BAR WITHOUT ROLL COVER

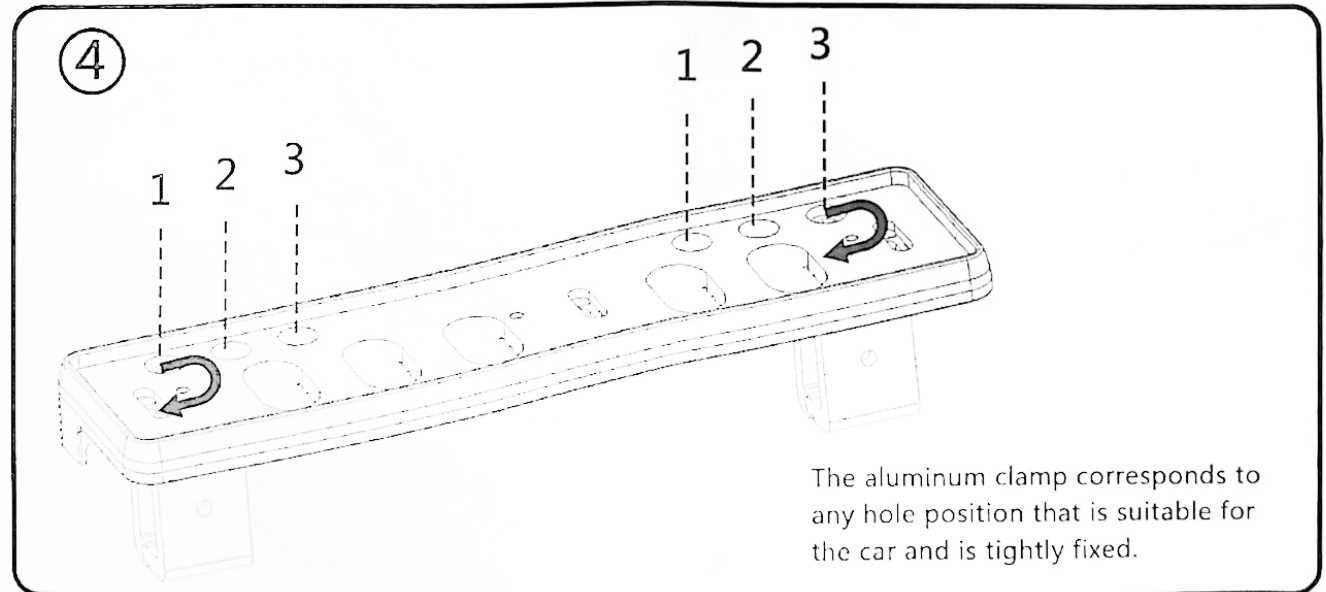
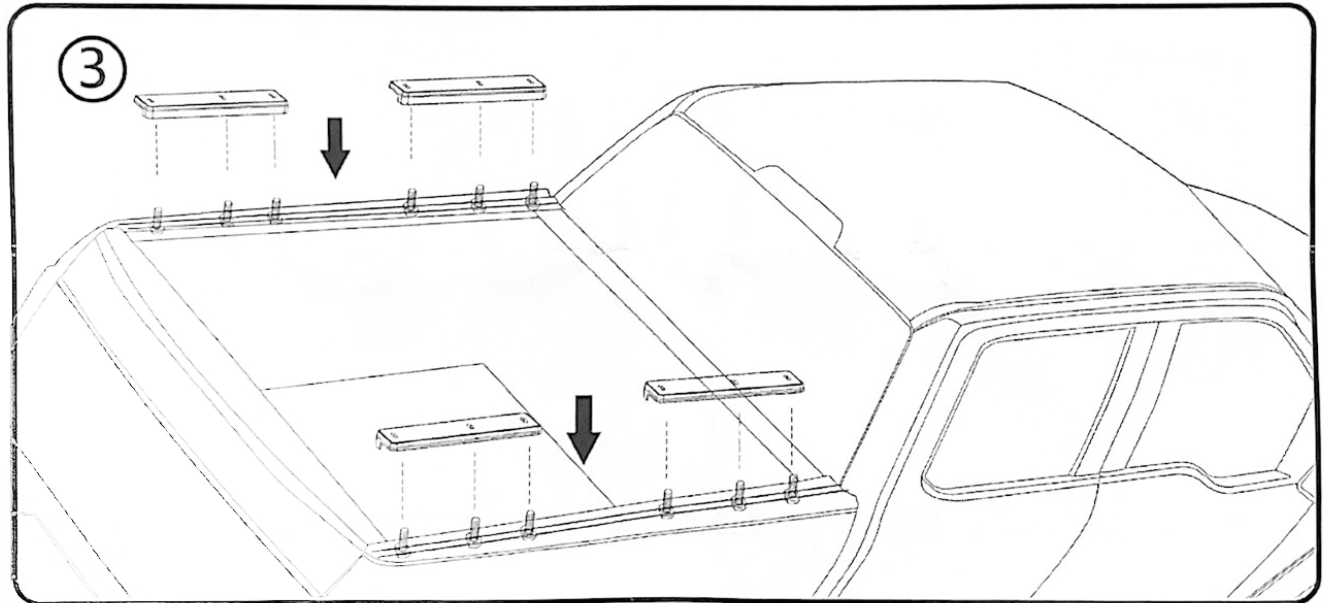
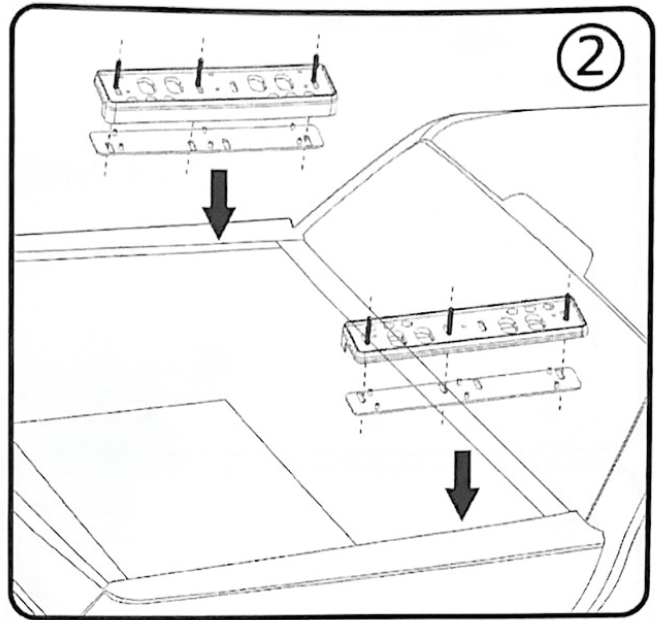
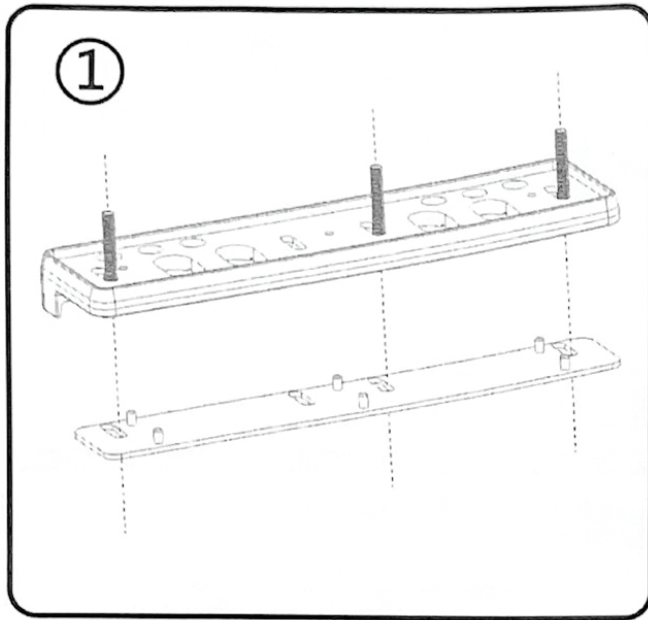

5

Measure the height that needs to be adjusted and adjust to the appropriate height.

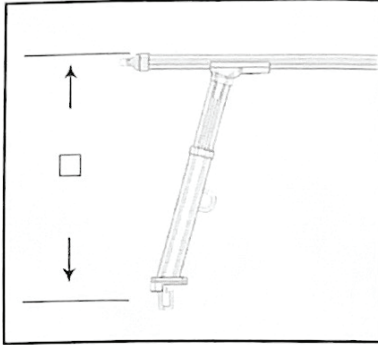

Loosen the screw on the post, adjust to the desired height, and observe the position of the scale value.

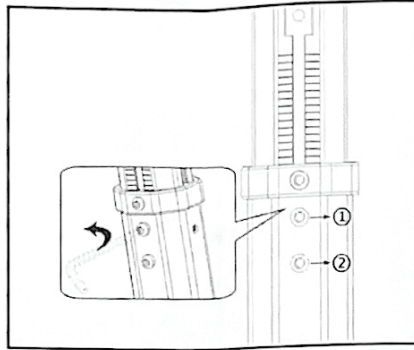

Loosen ①② screws properly, do not loosen all screws.

Repeat the previous step, adjust the 4 posts to the same height, and tighten all the screws on the 4 posts with a wrench.

Lock after adjusting properly.

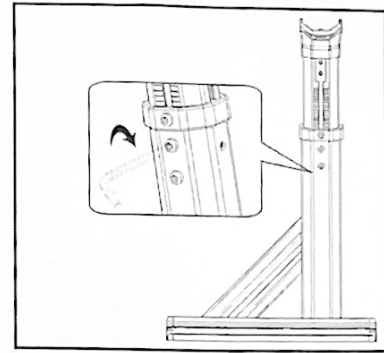

6

Correspond to Figure 2 screw position, and then fix the nut.

Measure the appropriate size, the two sides need to be symmetrical and consistent.

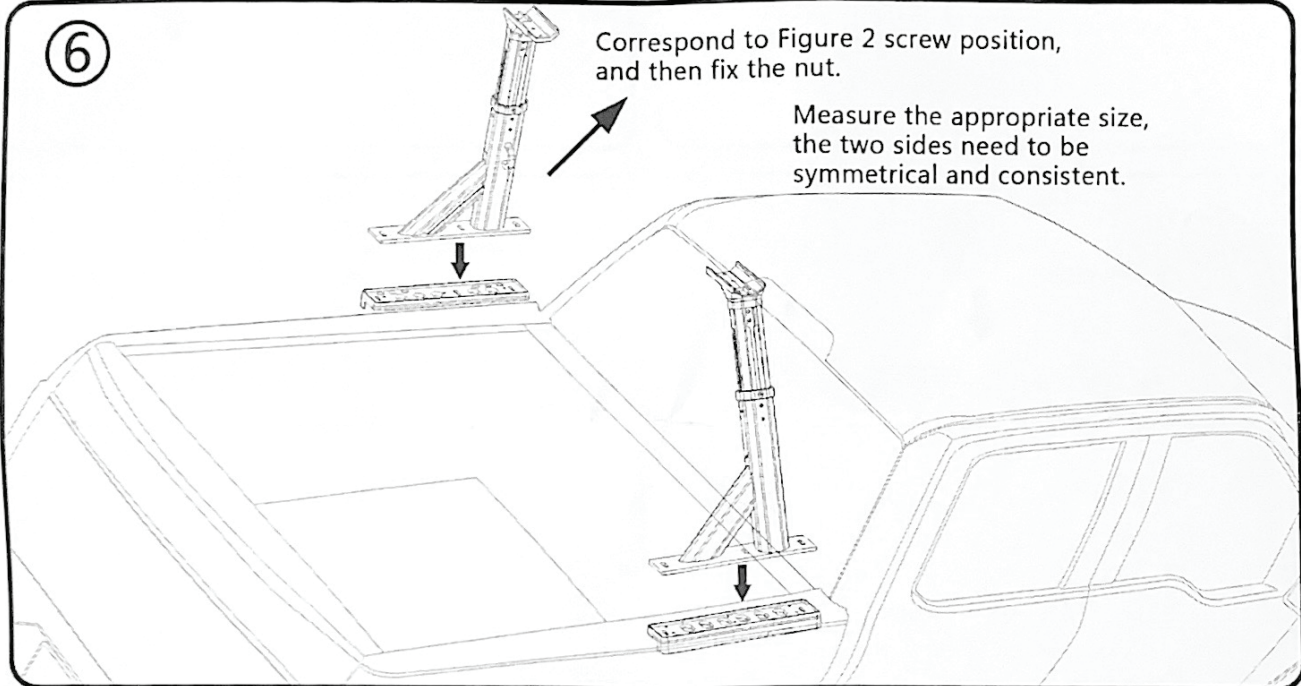

7

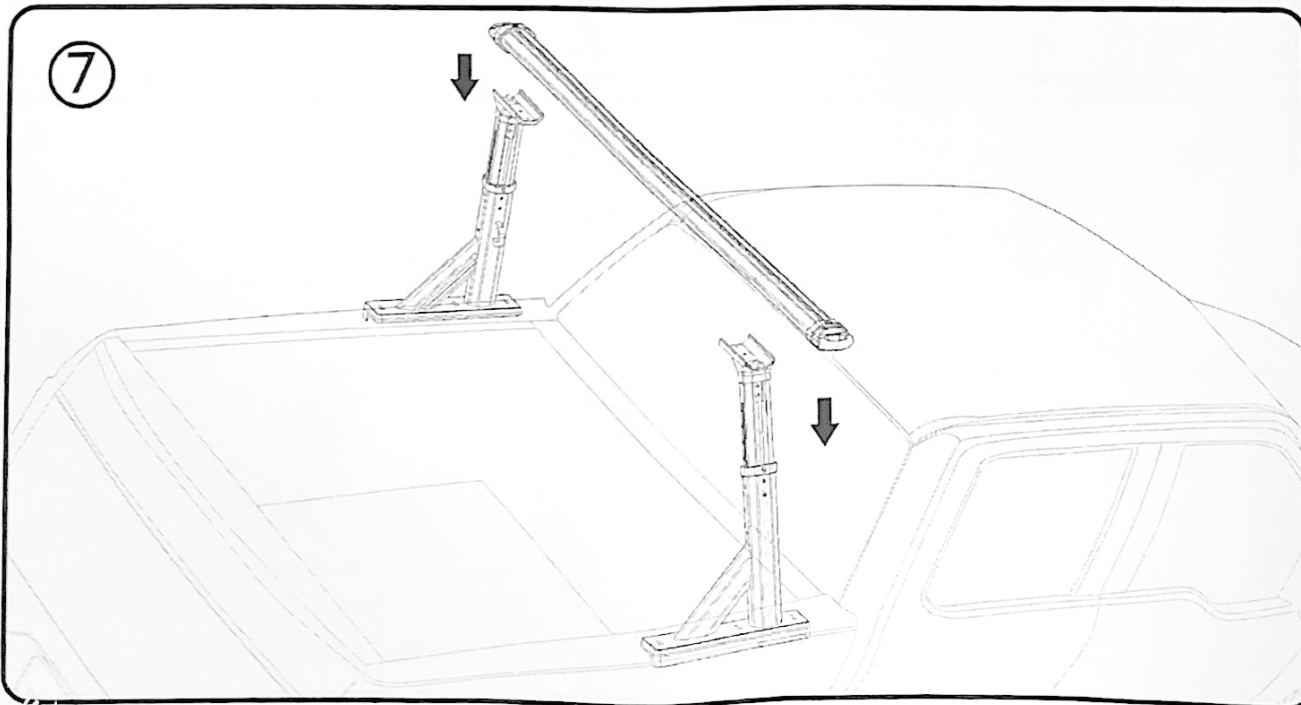

8

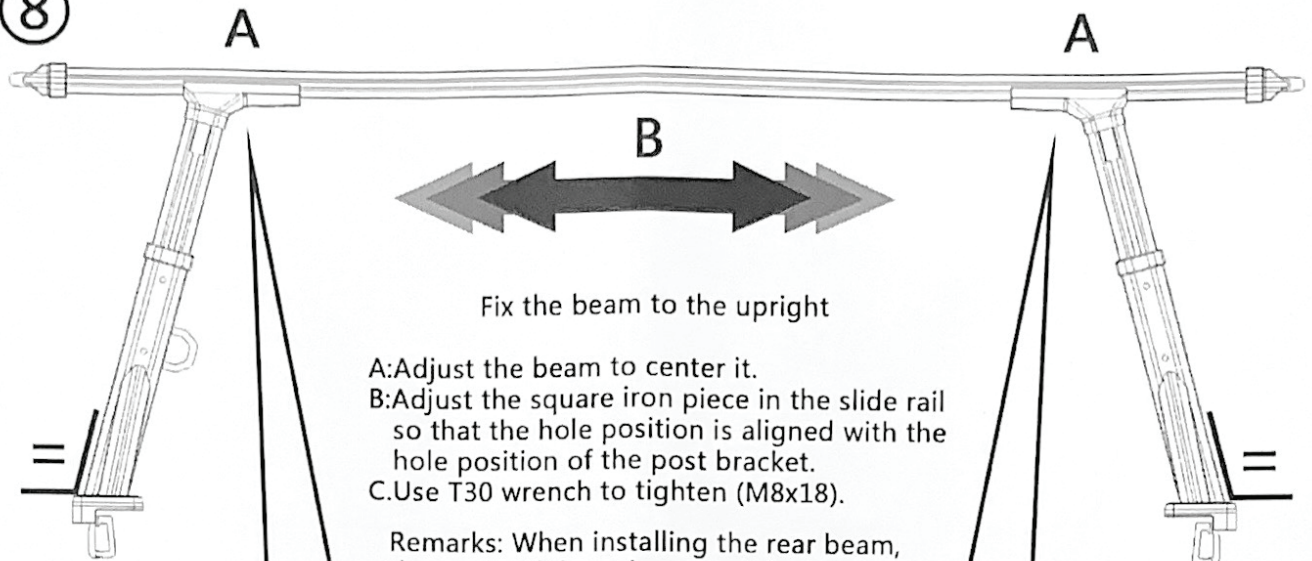

Fix the beam to the upright

- A: Adjust the beam to center it.
- B: Adjust the square iron piece in the slide rail so that the hole position is aligned with the hole position of the post bracket.
- C: Use T30 wrench to tighten (M8x18).

Remarks: When installing the rear beam, the angle of the column and the beam should remain the same as the front.

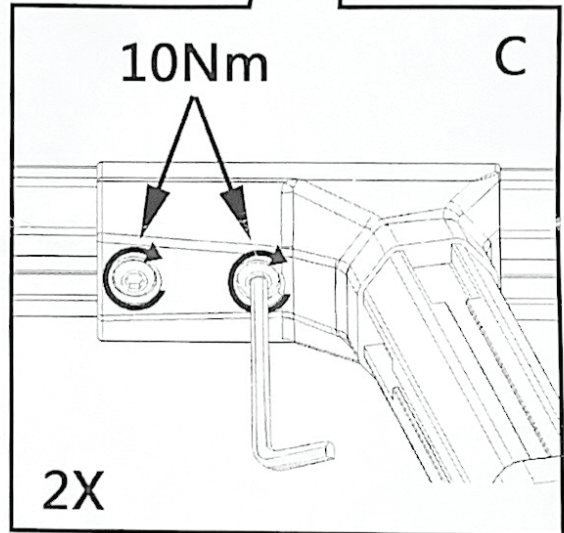
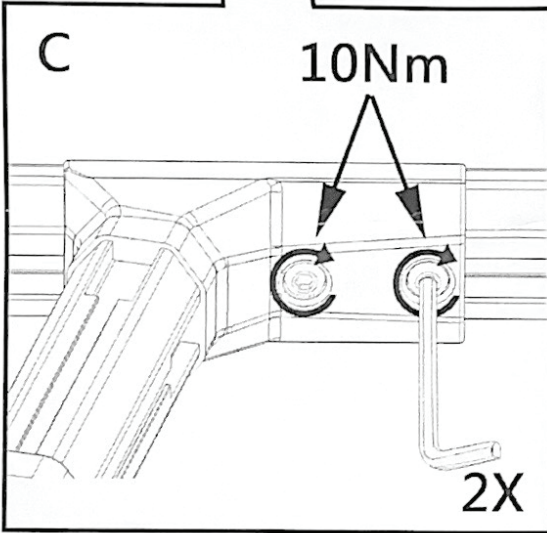

9

Check if the front system and rear system are right. Retighten hardware if necessary.

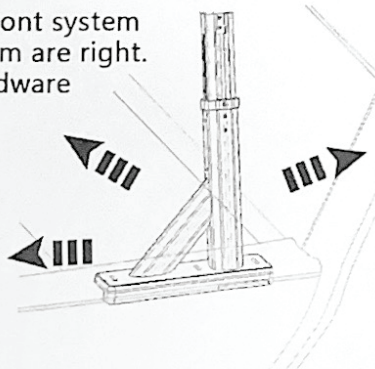

10

Adjust the crossbar size according to the distance of the column.

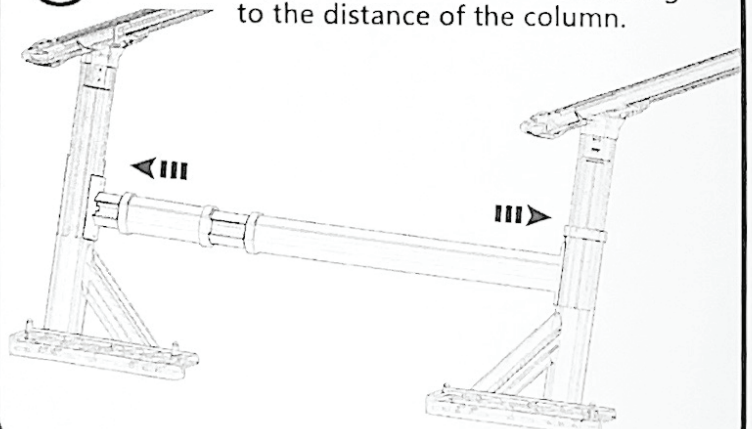

11

Align the holes, screw in the screws and tighten with a wrench.

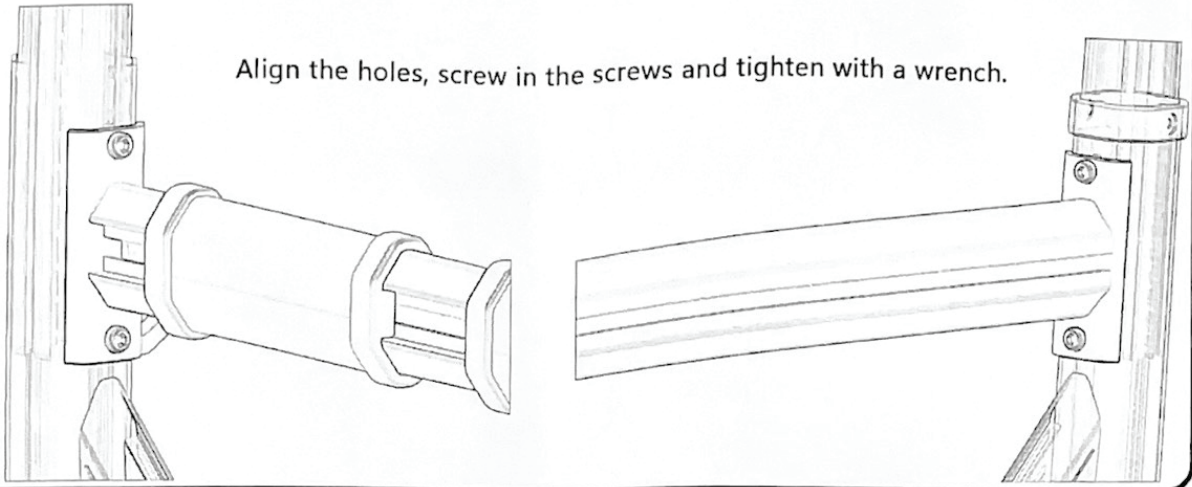

12

Installation effect display.

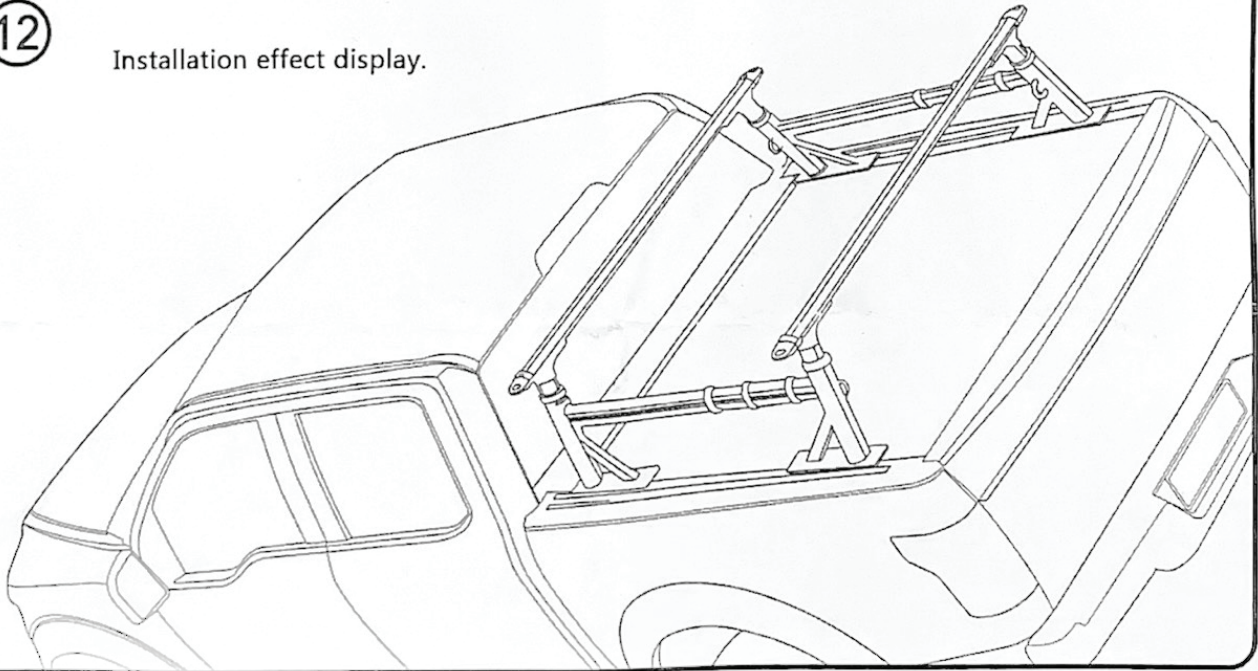

Check out the collection of truck bed accessories we offer.