



Roof Top Tent Owner's Manual

Congratulations on your purchase of an Overland Vehicle Systems Roof Top Tent. We strive to provide the ultimate camping experience for every camper. Your top quality, durable Roof Top Tent mounts directly to your roof rack or aftermarket roof bars and can be fully set up in just a few minutes. It can be left on your vehicle year-round.

Overland Vehicle Systems tents are made with the most durable materials that stand up to the most extreme conditions. High quality ripstop fabrics with superior ventilate coating provide excellent water and wind protection yet are more breathable than other tent brands on the market.

Most of your Overland Vehicle Systems Tent components have been fully assembled at the factory except for attaching the mounting tracks and the ladder to the base of the tent. Installation is composed of unpacking, attaching mounting tracks to the base of the tent, attaching the ladder, attaching the tent cover, and then mounting your Overland Vehicle Systems Tent onto your roof rack or aftermarket roof bars.



WARNING







Improper installation or use of your tent may result in serious injury or death. Follow these installation instructions carefully to ensure proper installation on your vehicle and safe use of your tent. Please check with your vehicle manufacturer for specified loading capacity of your roof rack. Not all factory roof racks or aftermarket roof bars can safely accommodate tent models.

Getting Started

This installation manual supports all current Overland Vehicle Systems tents. The installation process varies only slightly between certain models and is explained in detail within these pages.

Remove tent from box and place on a clean surface. Undo all the hook and loop straps so that you can open the tent enough to unzip the door and remove the contents.



Item	Quantity
 13mm Steel Bolt	8
 10mm x 40mm Bolt	8
 10mm x 20mm Steel Bolt	2
 10mm Nylock Nut	8
 13mm Nylock Nut	8
 Ladder Mounting Bracket	2
 Stainless Steel Washer	14
 Rubber Washer	2
 Metric Wrench 10mm	1
 Metric Wrench 13mm/15mm	1
 Channel Slider	8
 Steel Mount Plate	4
 Mounting Tracks	2

Tent Orientation on Your Vehicle

There are two mounting options for the orientation of your new Overland Vehicle Systems Tent. Either the tent will open so that the ladder extends off the back of your vehicle, "Rear Mounted," or the ladder extends off the side of your vehicle, "Side Mounted." Most of our customers choose to mount their tents with the ladder extending off the side of the vehicle, in "Side Mounted" orientation.

Either orientation works for larger vehicles, however, most sedans or smaller SUVs are better suited for the side mounted option.

Benefits of a rear mounted tent

Fits into narrow camping spaces.

1. Trunk or tail gate area at the rear of your vehicle is accessible from inside the annex

Benefits of a side mounted tent

1. Allows for bicycle racks and other tow hitch/bar accessories to be installed without interfering with your tent operation.
2. Closed tent width will fit inside the roof dimensions of most cars and SUV's. i.e. the tent base will not extend beyond the roof line of your vehicle when closed.
3. Typically, does not require cutting of the mounting tracks.

Tent Assembly

1. Four pre-drilled holes are in the center area of the tent base for attaching the mounting tracks. Align the holes in the mounting tracks over the holes in the base.

Rear Mounted



Mount perpendicular to hinge



Mount parallel to hinge

Rear Mounted



Mount parallel to hinge



Mount perpendicular to hinge

2. Slide the 10mm nylock nuts into the inner slot in the center of the mounting tracks until they are aligned with the holes in the mounting tracks and the base.

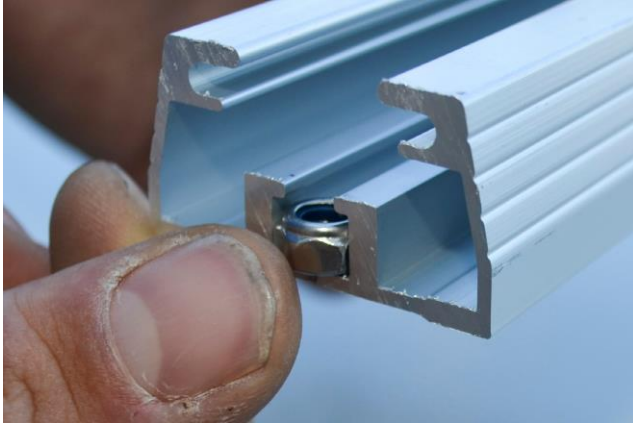

3. Using the supplied 10mm bolts, add two steel washers to each bolt. Slide your hand between base and mattress and insert bolts with washers into the pre-drilled holes. You may need to poke holes through the tape to insert bolts. The bolts should pass through the holes in the tent base and the mounting tracks, into the nuts in the inner slot of the mounting track. Reach under the mattress and tighten the bolts firmly using the supplied 10mm wrench.

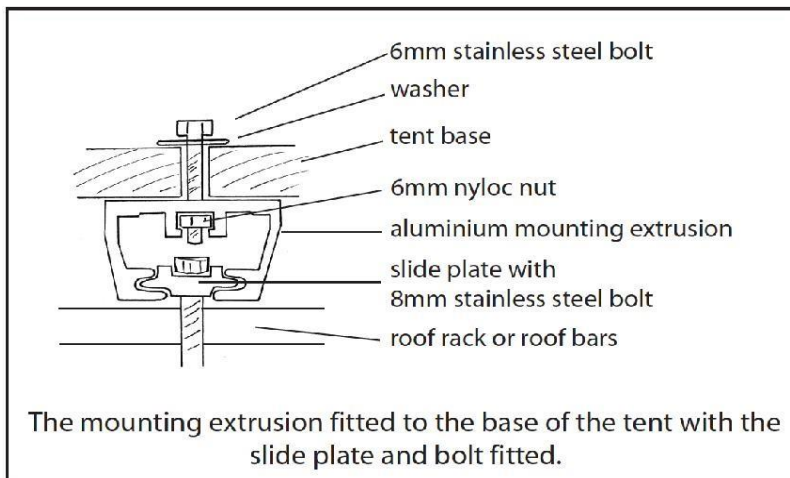
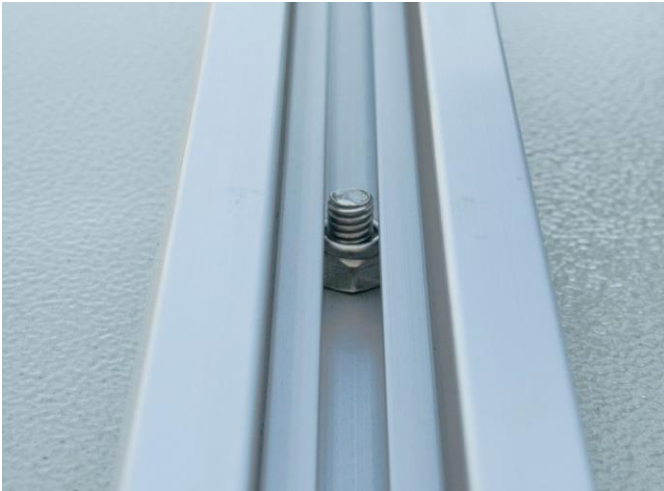

4. Attach the brackets to the ladder by threading the shorter bolt through a steel washer, the lateral side of the ladder bracket, the rubber washer, and the hole in the ladder, followed by a nylock nut.



Cover Attachment

1. To attach the travel cover, slide the rounded fabric end of the cover into the rounded C-channel at the hinge side of the tent base. Make sure the cover is oriented, so the exterior side of the cover faces up when you pull the cover over the tent



2. Fasten the hook and loop straps on either side of the tent to hold the canopy in place



3. Zip the travel cover to the base along the other three edges, taking care that the tent fabric does not become caught in the zipper. Secure the two long hook and loop straps over the top of the travel cover.



Attachment to The Roof Rack

1. Place the tent on top of your vehicle rack system, ensuring the mounting tracks are perpendicular to the bars they will mount to, and the tent is centered on the roof rack. Position the hinge so that the tent will open to the desired side.
2. Slide the 13mm bolts and channel sliders into the mounting tracks. Lift one side of the tent to position one set of bolts and channel sliders on the inner side of the roof rack bar and an additional set on the opposite side. Repeat on all four corners.



3. At each of the four corners where the rack bars and mounting tracks cross, using a steel mounting plate and nylock nuts to secure the bolts on either side of the bar. Tighten all eight bolts securely with the included nuts and wrench. Check all the mounting bolts and brackets periodically during use.



4. After ensuring the tent is positioned correctly and all eight bolts are tightened securely, insert rubber end caps into the ends of the mounting tracks. This may require light taps from a hammer



Tent Set Up

1. Release the straps over the travel cover.
2. Unzip the travel cover. You can remove it, roll it up, or let it hang off the side of your vehicle.
3. Unbuckle the straps on the sides of the tent and across the ladder.
4. Use the ladder as leverage to open the tent by pulling straight back until the ladder rests firmly on the ground. Assure all the steps on the telescoping ladder are locked. The tent base should be level and the ladder should form a 60° angle with the ground.
5. To adjust the ladder height, pull on the locking pins in front of ladder and adjust to the desired height. Make sure the pins lock at the desired height.
6. Unfasten the grommets on the awning and rainfly. Locate the fabric slits in the tent skirt. Pre-drilled holes are located underneath each slit. Insert the rainfly rod at a 45° angle into the hole and bend slightly to hook the other end through the grommet. Repeat this process for both holes in the awnings and both holes at either end of the rainfly.



To close the tent, remove the rainfly rods. Extend the ladder, using it as leverage to close the tent. To collapse the ladder, press the red buttons at the base of the ladder.

Fasten the straps at the sides of the tent and across the ladder before zipping on the cover. Secure with the hook and loop straps that run across the cover.



Storage and Handling

Clean and dry your tent after each camping trip:

1. Open the tent fully and brush / vacuum inside.
2. Clean the fabric as needed using a mild detergent, warm water, and a soft to medium brush. Rinse fabric of all detergent prior to drying.
3. Dry tent in the sun with all windows open. The tent must be completely dry before storage, or mildew and mold may occur. This is especially necessary after camping in rain or wet conditions.
4. Using a small brush, remove dirt from zippers. Use a silicon spray to keep zippers lubricated.
5. Using a small brush, remove dirt from zippers. Use a silicon spray to keep zippers lubricated.
6. Wash mattress pad and hang dry