

Truck Transmission Bearing Service Set

OTC's Truck Transmission Bearing Service Set (7070A) is designed to remove input shaft bearings, main transmission front countershaft bearings, and auxiliary section countershaft bearings on Fuller models RT, 1100, 600, RTO 610-613, 6600, 8600, 900, 910-913, 915, 9500, 12,500, 12,600, 14,600, and 15,600 twin countershaft truck transmissions. The 7070A also removes 1600 and 1800 series end yokes.

Parts List			
Item No.	Description	Part No.	Qty
1	Cross Block	42542	1
2	Forcing Screw	34703	1
3	Hex Nut (1/2-13)	10208	2
4	Washer (for 1/2" bolt)	12004	2
5	Long Leg	310553	2
6	Short Leg	310552	2
7	Adapter	202893	2
8	Step Plate	202916	1
9	Sleeve	202894	1
10	Collet Half	48387	2

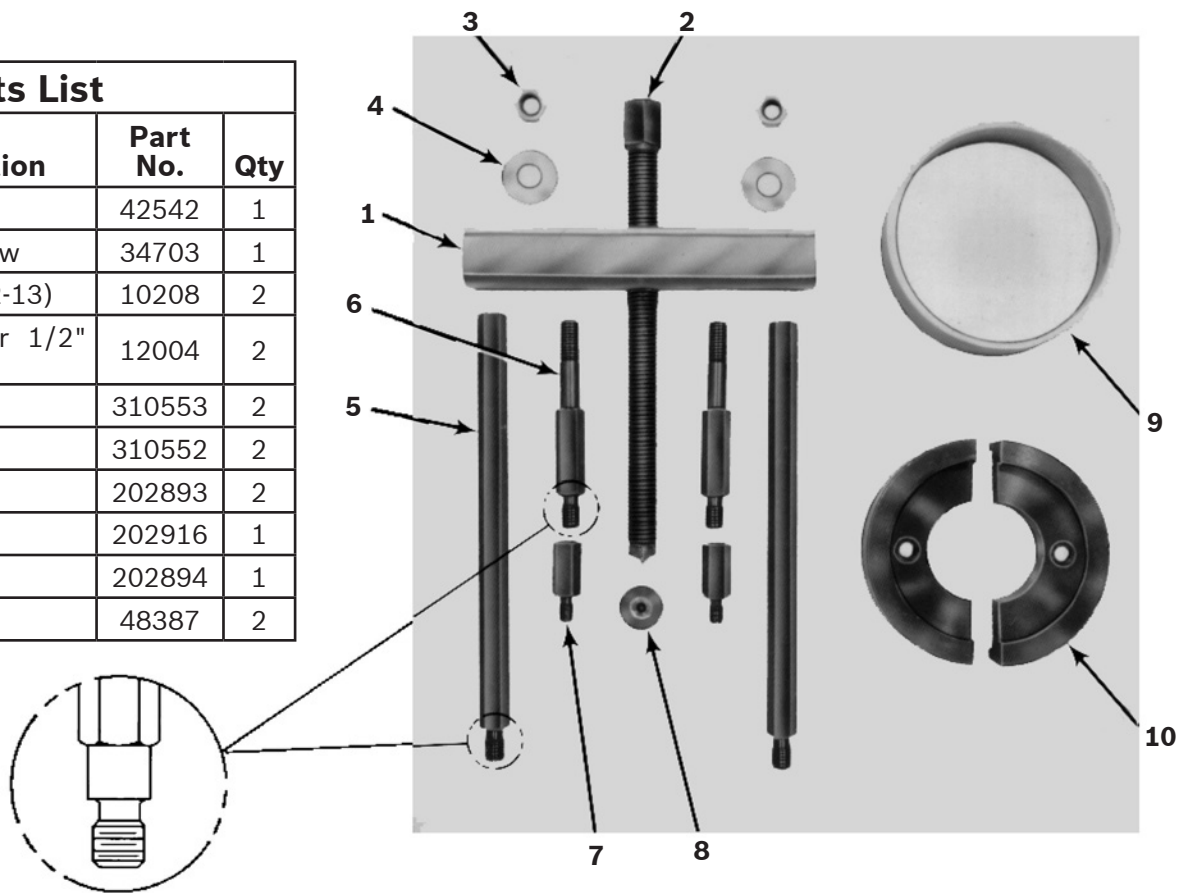

SAFETY PRECAUTIONS

WARNING: To help prevent personal injury:



- Wear eye protection that meets ANSIZ87.1 and OSHA standards.
- Apply force gradually. Do not try to speed removal by using an impact wrench on the forcing screw.

REMOVING the SHAFT BEARING

NOTE: This operation can be performed without removing the clutch housing from the transmission.

1. Assemble cross block, screw, and legs to transmission case as shown in Figure 1. Note that all three leg lengths (Items, 5, 6, & 7) are used.
2. Push shaft inward through bearing approximately 1/4 to 3/8 inch.
3. From inside case, tap drive gear shaft and bearing forward as far as possible to expose snap ring. Remove tool from case.
4. Assemble collets and sleeve to bearing as shown in Figure 2.
5. Attach puller legs (Items 5 & 6) to collet, and assemble cross block and screw as shown in

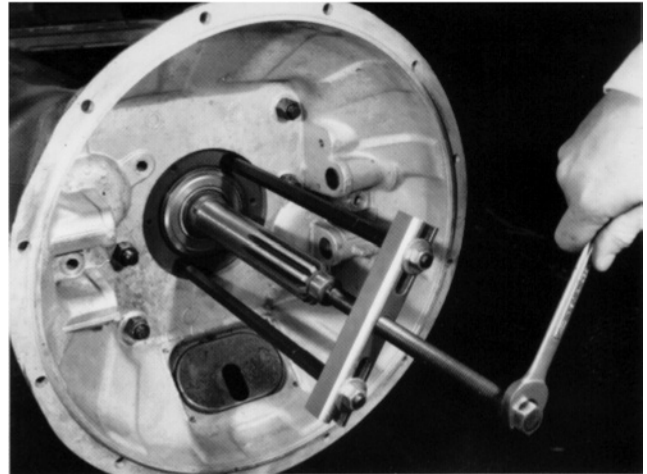

FIGURE 1

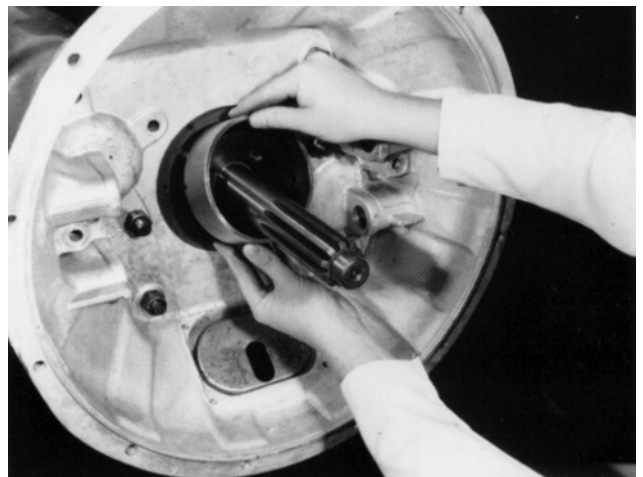

FIGURE 2

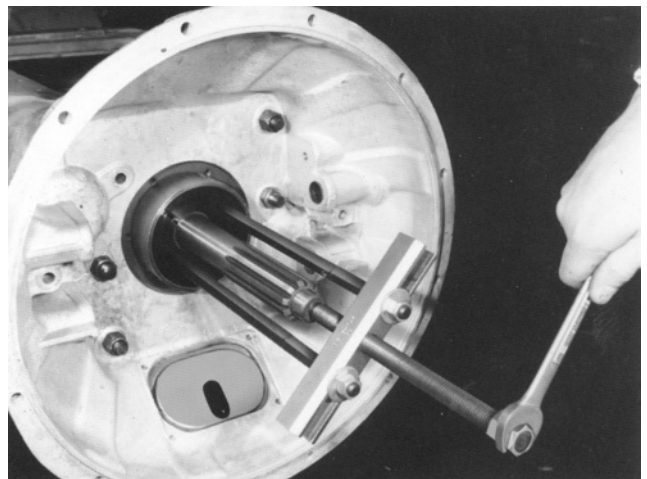
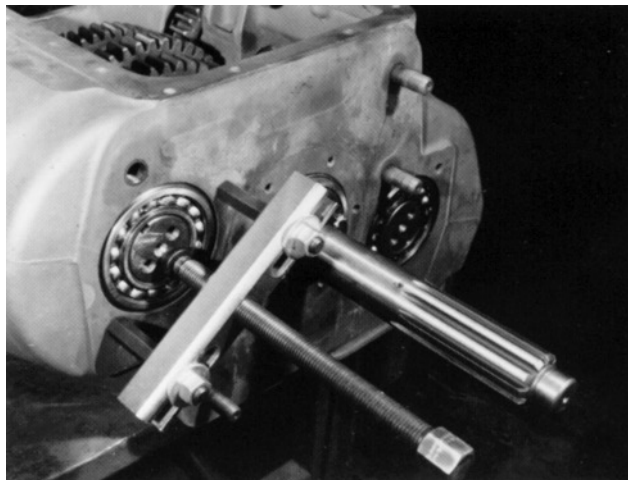
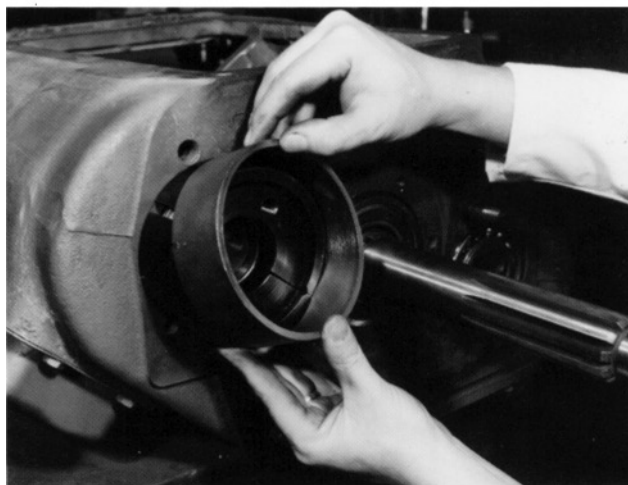
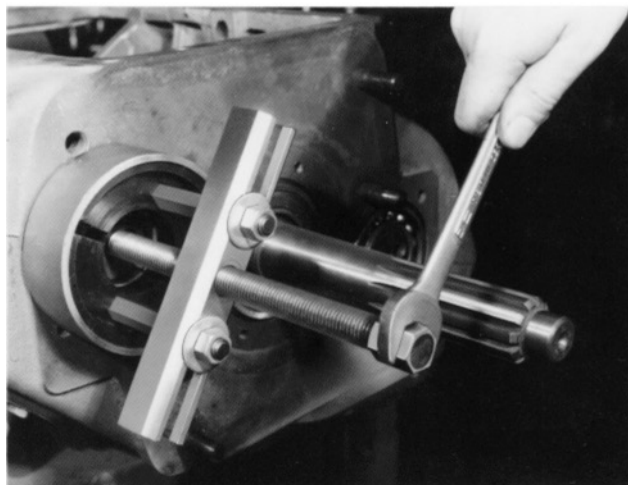

FIGURE 3

REMOVING the FRONT COUNTERSHAFT BEARING, MAIN TRANSMISSION

Figure 3. Remove bearing.

1. Assemble cross block and screw to transmission case with step plate (Item 8) and two puller short legs (Item 6). See Figure 4.
2. Push countershaft toward inside of transmission case approximately 1/4 to 3/8 inch.
3. Drive against rear of countershaft to move bearing assembly forward as far as possible to expose bearing snap ring.
4. Remove legs, cross block, and screw from transmission case.
5. Assemble collets and sleeve to bearing. See Figure 5.
6. Attach two puller short legs (Item 6) to collet, and assembly cross block and screw. See Figure 6.

**FIGURE 4****FIGURE 5****FIGURE 6**

Parts List & Operating Instructions

Remove bearing.

REMOVING the AUXILIARY CASE COUNTERSHAFT BEARING

1. Assemble cross block and screw to transmission case with two puller short legs (Item 6) and two adapters (Item 7). See Figure 7.
2. Push countershaft toward inside of transmission case approximately 1/4 to 3/8 inch.
3. Drive against rear of countershaft to move bearing assembly forward as far as possible to expose bearing snap ring.
4. Remove legs, cross block, and screw from transmission case.
5. Assemble collets and sleeve to bearing. See Figure 8.
6. Attach two puller short legs (Item 6) to collet, and assemble cross block and screw. See Figure 6.

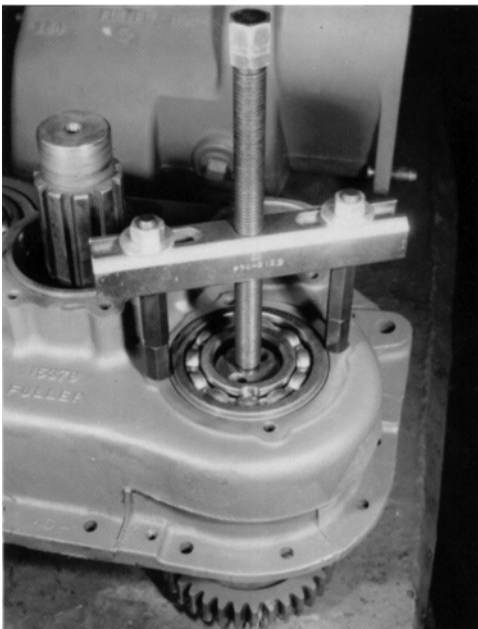

FIGURE 7

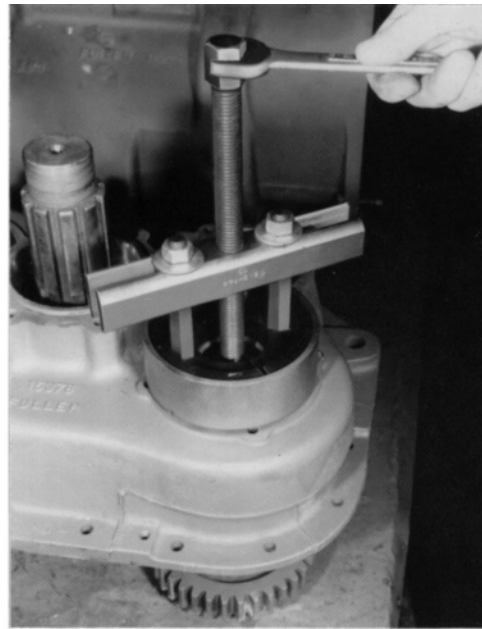

FIGURE 8

Remove bearing.

REMOVAL OF END YOKE

1. Remove puller screw from cross block assembly, and slide cross block into bearing bores. See Figure 9.
2. Thread screw through cross block against output shaft. Tighten screw until yoke is removed.

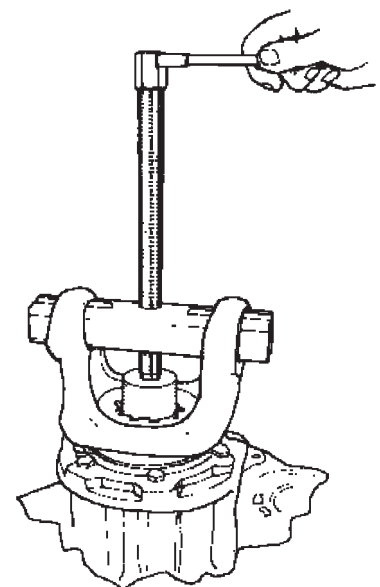

FIGURE 9