

GM Ball Joint Update Kit

(Use with OTC Ball Joint Kit 6530 or 7918)

Application: Use with an OTC ball joint press to remove and install upper and lower ball joints on the GM vehicles listed.

Parts List

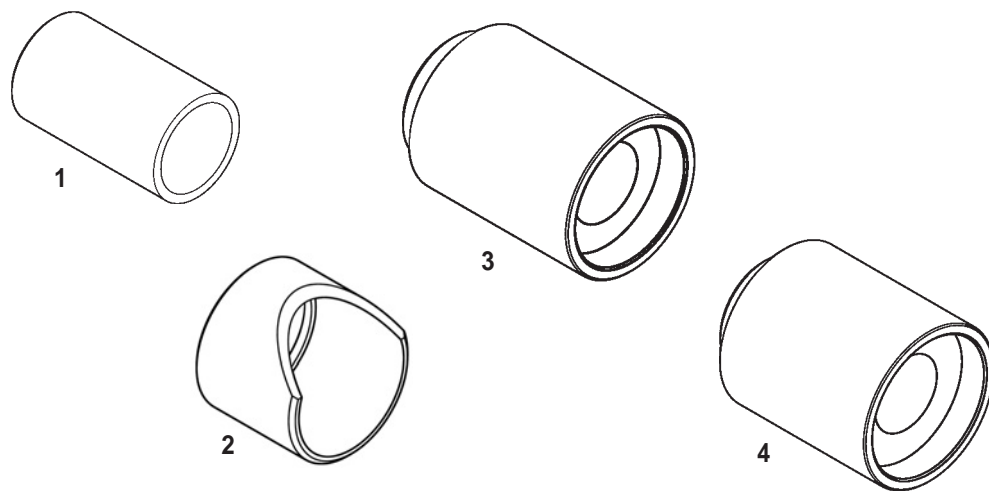

Item No.	Part No.	No. Req'd	Description
1	531738	1	Installer Cup
2	537499	1	Receiving Tube
3	537500	1	Remover
4	537501	1	Remover

Safety Precautions

 **Caution:** To prevent personal injury,



• Wear eye protection that meets ANSI Z87.1 and OSHA standards.



• Before repairing a vehicle, block the wheels to prevent the vehicle from moving.

• Check the final alignment of the ball joint press and tooling with the components before exerting pressure to remove or replace a ball joint.

Parts List & Operating Instructions

Operating Instructions

Applications: 1999-2000 1/2-ton Silverado, Sierra 4WD (std. cab)
2001-2004 1/2-ton Silverado, Sierra 2WD/4WD
2000-2004 1/2-ton Suburban, Tahoe, Yukon, Denali 2WD/4WD
2002-2004 1/2-ton Avalanche 2WD/4WD
2002-2004 Cadillac Escalade 2WD/4WD
2003-2004 1/2- & 3/4-ton Express & Savana Van 4WD

1. Position the tools as shown to remove or install the upper or lower ball joint. **Note for installation:** Clean the control arm or knuckle, and coat the I.D. with a suitable lubricant.
2. Tighten the forcing screw until it meets the cup, and check the alignment of all tooling and components. Continue tightening the forcing screw until the ball joint is removed or installed.

Removing and Installing the Lower Ball Joint

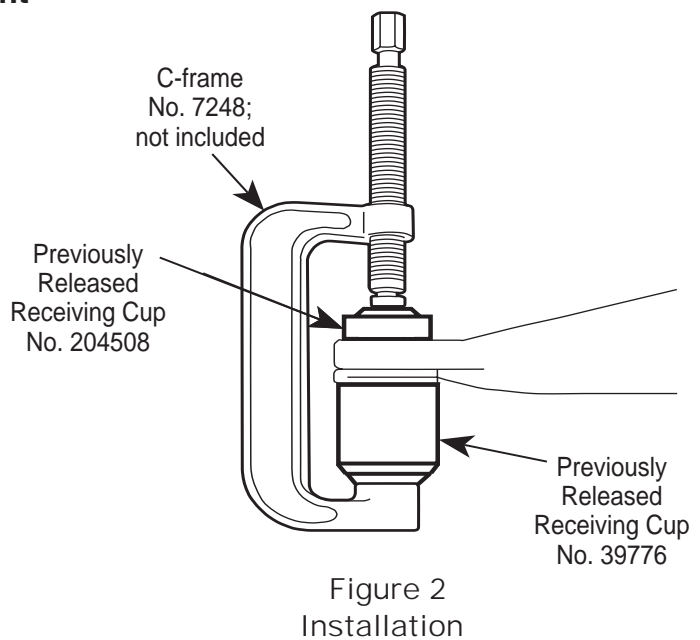
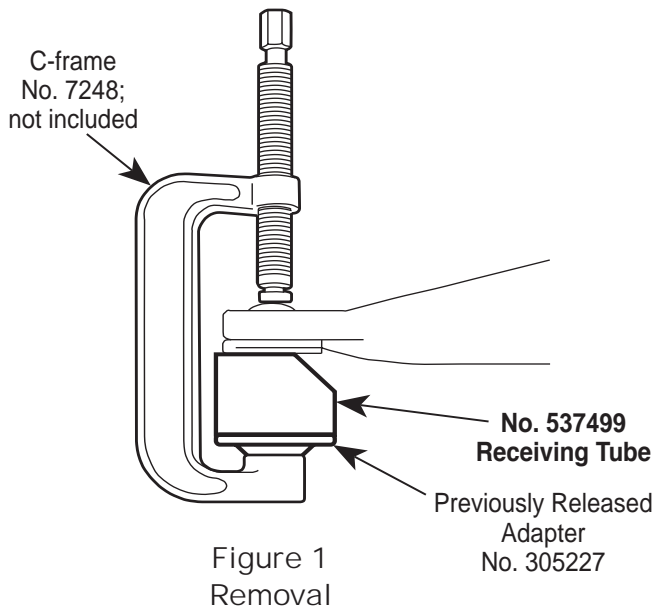

Removing and Installing the Upper Ball Joint

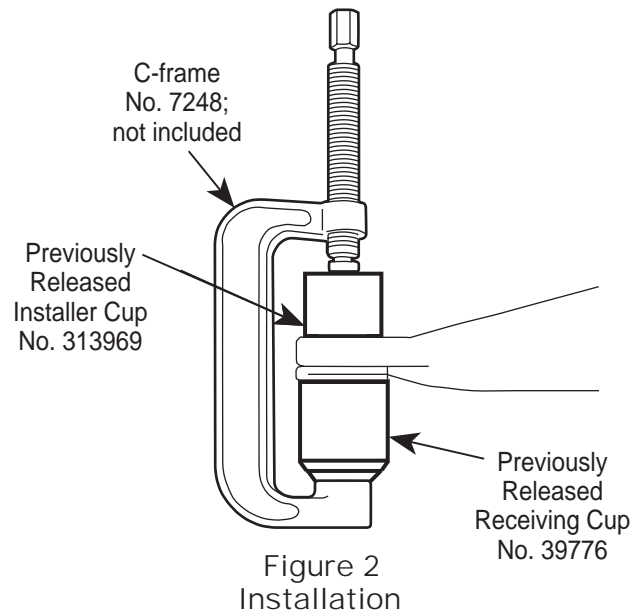
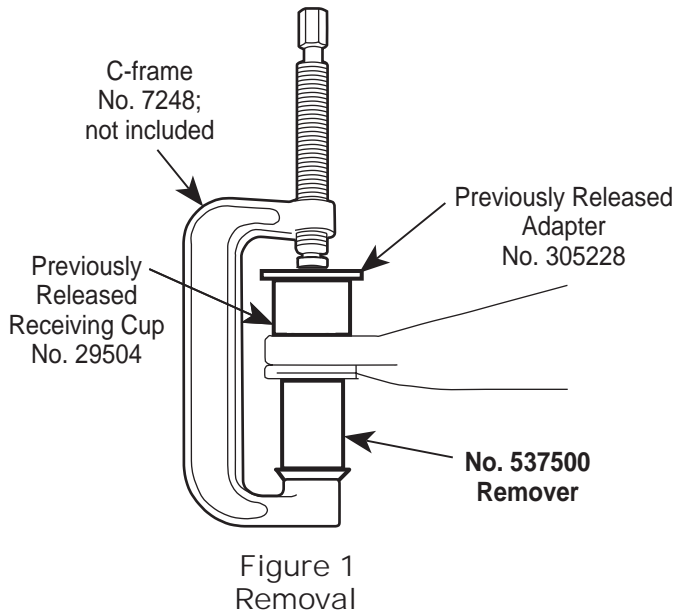

Operating Instructions

**Applications: 2002-2005 Chevrolet TrailBlazer,
GMC Envoy, & Oldsmobile Bravada**

1. Position the tools as shown to remove or install the upper or lower ball joint. **Note for installation:** Clean the control arm or knuckle, and coat the I.D. with a suitable lubricant.
2. Tighten the forcing screw until it meets the cup, and check the alignment of all tooling and components. Continue tightening the forcing screw until the ball joint is removed or installed.

Removing and Installing the Lower Ball Joint

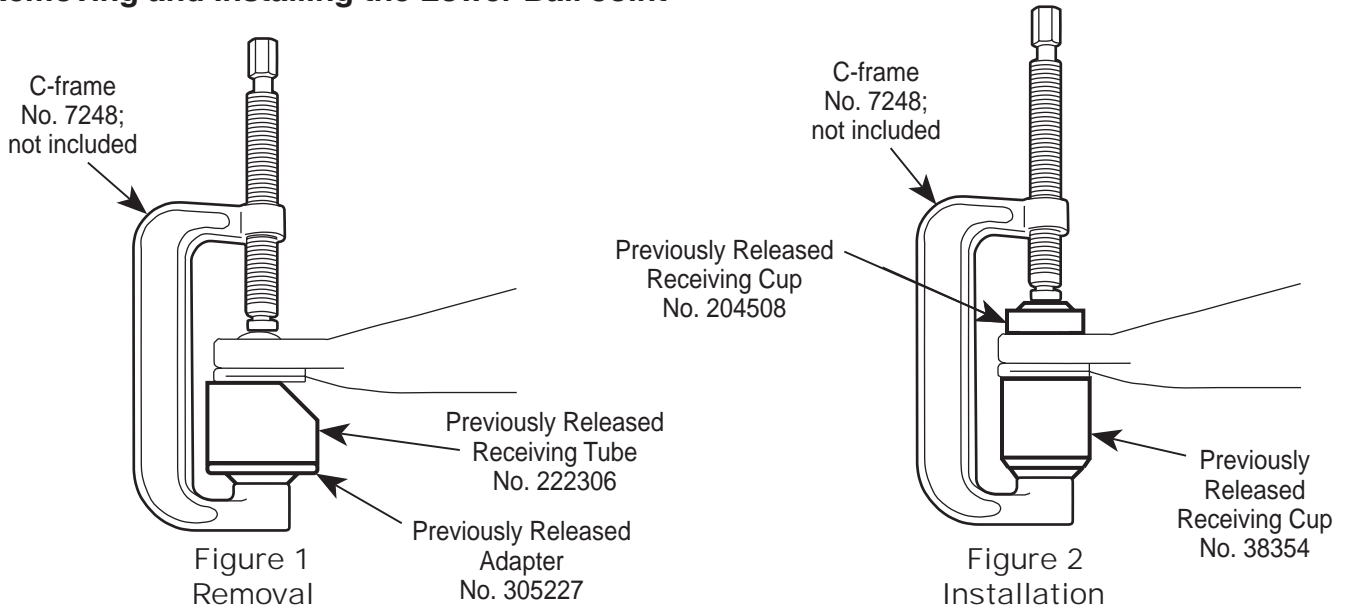

Removing and Installing the Upper Ball Joint

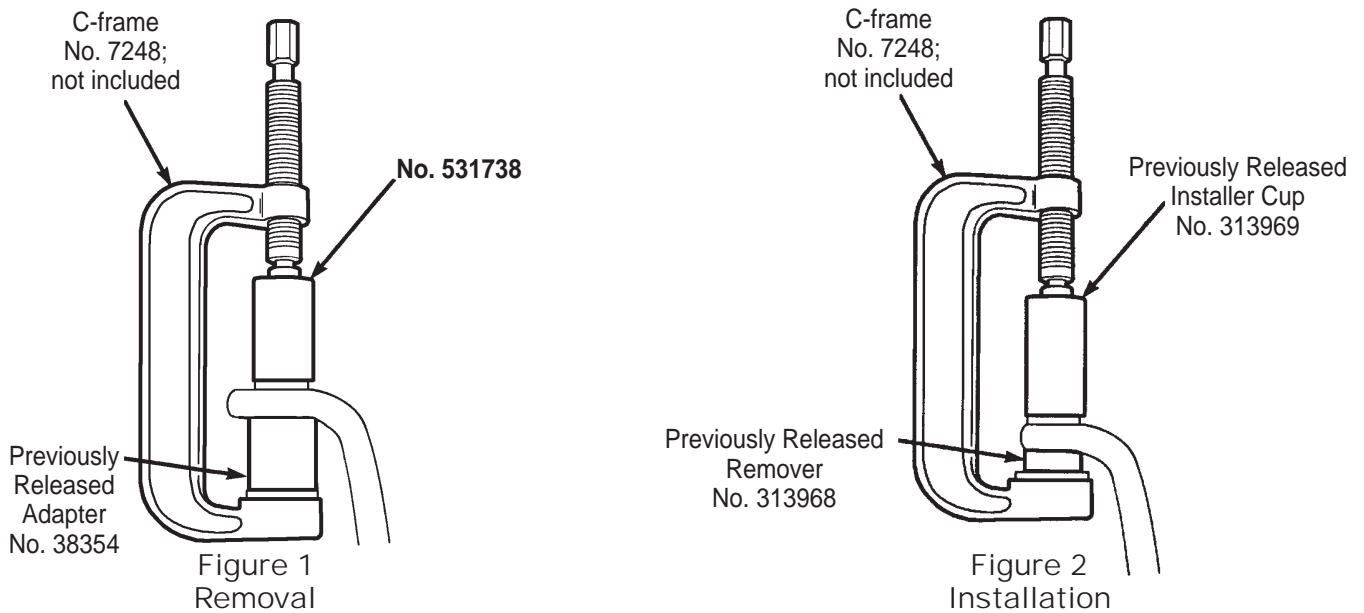

Operating Instructions

Applications: 1995-1999 Chevrolet Tahoe, GMC Yukon 4WD
2000 Chevrolet Tahoe Z71 4WD
1995-1999 1/2- & 3/4-ton Suburban 4WD
1995-2000 1/2-, 3/4-, & 1-ton Chevrolet & GMC 4WD trucks
1999-2000 Cadillac Escalade 4WD
2001-2003 1/2-ton Sierra & Silverado 2WD/4WD HD Crew Cab
1999-2004 3/4-ton Sierra & Silverado 2WD/4WD
2000-2004 3/4-ton Suburban & GMC Yukon 2WD/4WD
2001-2004 1-ton Sierra & Silverado 4WD
2002-2004 3/4-ton Avalanche 2WD/4WD
2003-2004 Hummer H2

1. Position the tools as shown to remove or install the upper or lower ball joint. **Note for installation:** Clean the control arm or knuckle, and coat the I.D. with a suitable lubricant.
2. Tighten the forcing screw until it meets the cup, and check the alignment of all tooling and components. Continue tightening the forcing screw until the ball joint is removed or installed.

Removing and Installing the Lower Ball Joint

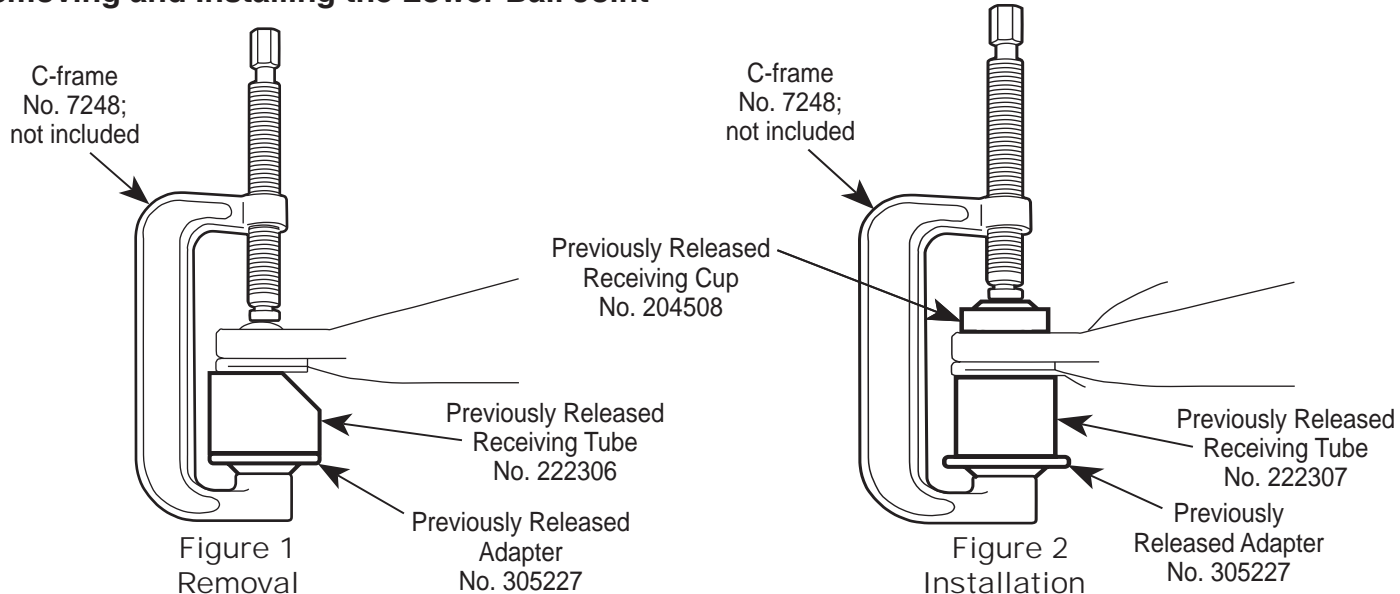

Removing and Installing the Upper Ball Joint (with press-in ball joint)

