

StrutTamer Stand

(designed for OTC StrutTamer No. 6580)

Parts List

Item No.	Part No.	Qty.	Description
1	527697	8	Hex Locknut (M12 x 1.75)
2	218920	2	Hex Hd. Cap Screw
3	223328	1	Tool Tray
5	526433	1	Decal
6	527573	2	Flex Grip Handle
7	527572	1	Vertical Frame
8	527698	2	Hex Hd. Cap Screw (M12 x 1.75 x 120)
9	205727	2	Wheel (4" dia.)
10	212336	4	Cap Screw
11	223270	4	Rubber Bumper
12	527700	4	Hex Nut (1/4-20 UNC)
13	527699	4	Machine Screw
14	519920	2	Leg
15	519919	1	Cross Member

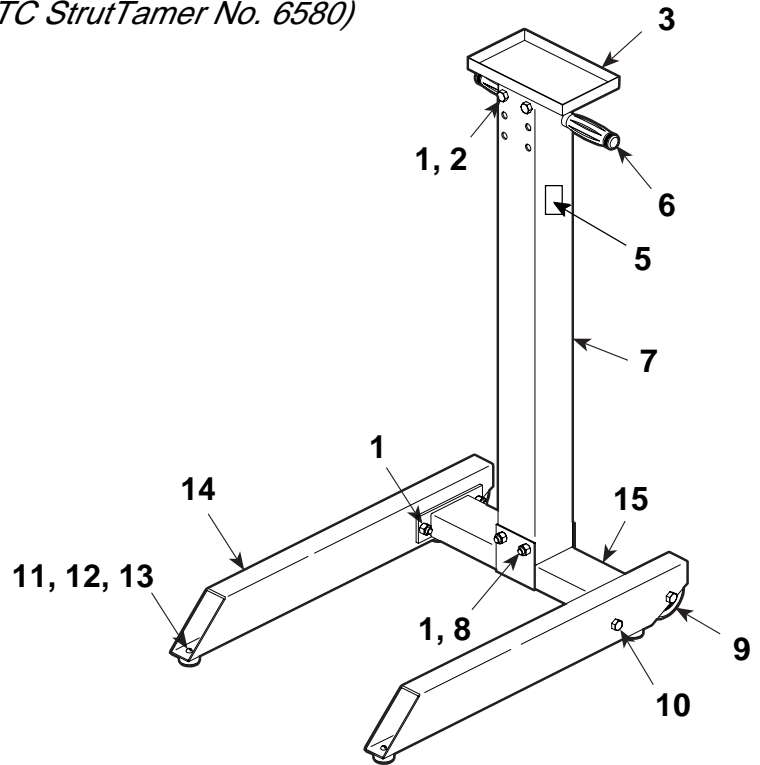

Install tray offset to back of stand, and flush with front of frame.

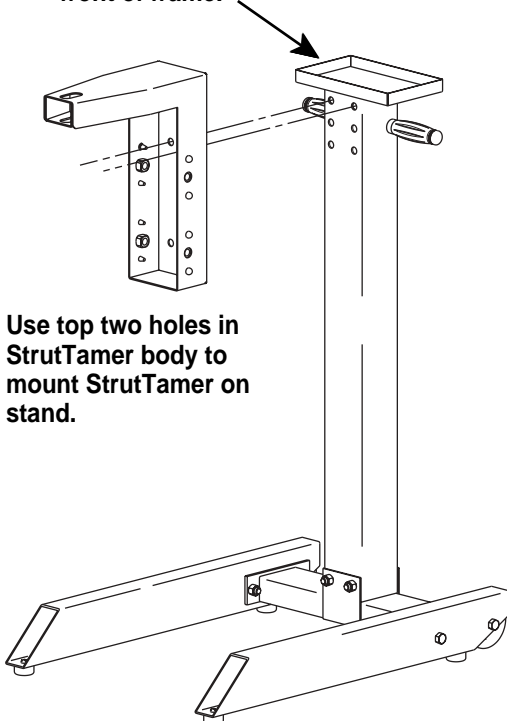

Use top two holes in StrutTamer body to mount StrutTamer on stand.

Assembly Instructions

(Item numbers refer to the parts list.)

1. Insert machine screws (13) through rubber bumpers (11), and use hex nuts (12) to attach rubber bumpers to legs (14).
2. Attach legs (14) to cross member (15) using cap screws (10) and hex locknuts (1). Use cap screws (10) and locknuts (1) to attach wheels (9) to legs (14).
3. Position vertical frame (7) between tangs in cross member, with StrutTamer mounting holes toward front of stand as shown. Use cap screws (8) and locknuts (1) to attach frame to tangs.
4. There are three pairs of mounting holes which may be used to mount the StrutTamer to the mobile stand. Select one pair which would hold the StrutTamer at the desired height after assembly. Use cap screws (2) and locknuts (1) to assemble StrutTamer to stand.
5. The tool tray (3) is designed to be offset to the back of the stand, and flush with the front of the frame, so it doesn't interfere with the StrutTamer. Install tool tray by pushing mounting tangs into frame.