

Ball Joint Super Set

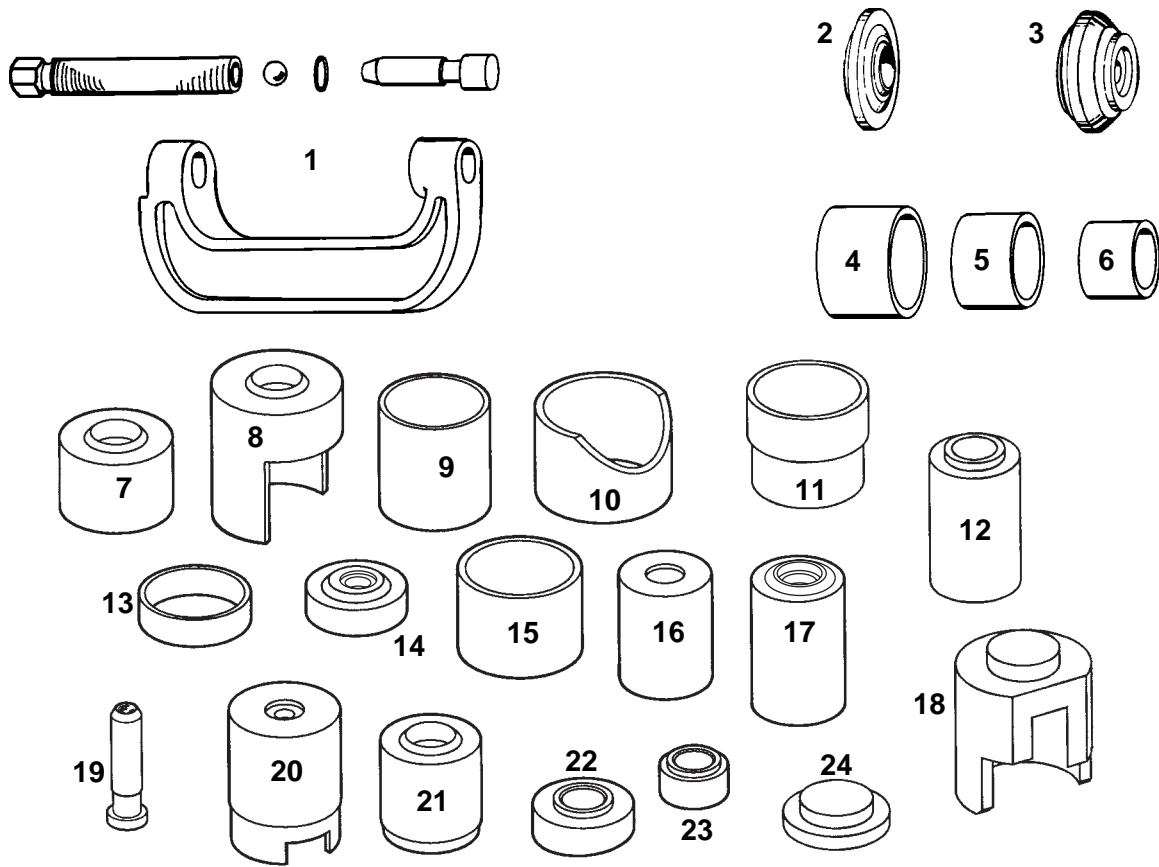

	Page
Parts List	2
Safety Precautions	2
Applications :	
Press-Fit Ball Joints	3
Dana 44 Axles	4
GM 4WD	5
Ford 2WD Van	6
Dodge / Jeep 4WD	7
Honda	8

Parts List / Safety Precautions



Item No.	Part No.	No. Req'd	Description
1	7248	1	C-Frame Press (<i>consists of 1 ea.: 37703 forcing screw; 14472 steel ball; 10273 o-ring; 29501 plug; 41925 c-frame</i>)
2	305227	1	Installing Adapter
3	305228	1	Removing Adapter
4	29503	1	Receiving Tube
5	29504	1	Receiving Tube
6	29505	1	Receiving Tube
7	39976	1	Receiving Cup
8	313444	1	Ball Joint Remover
9	222305	1	Receiving Tube
10	222306	1	Receiving Tube
11	314425	1	Receiving Cup
12	314426	1	Removing Adapter

Item No.	Part No.	No. Req'd	Description
13	222304	1	Receiving Tube
14	204508A	1	Receiving Cup
15	222307	1	Receiving Tube
16	313969	1	Installing Cup
17	38355A	1	Installing Cup
18	314427	1	Receiving Cup
19	314392	1	Live Center Forcing Screw Plug
20	313967	1	Remover Cup
21	38354	1	Receiving Cup
22	313970	1	Installer
23	313968	1	Remover
24	314428	1	Installing Adapter
	514480	1	Storage Case (<i>not shown</i>)

Safety Precautions

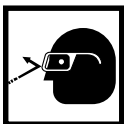

CAUTION : To prevent personal injury when using these tools,

- Wear eye protection that meets ANSI Z87.1 and OSHA standards.
- Before performing repairs on a vehicle, block the vehicle wheels to prevent movement of the vehicle.
- Check the final alignment of tooling and components before using the C-frame to exert pressure.



Shaded areas reflect the last revisions made to this form.

Press-Fit Ball Joints

Application : Most cars and light trucks that have press-fit type ball joints.

This assembly enables the user to remove and install ball joints without removing the control arm from the vehicle.

NOTE: Some cars and light trucks may have the upper ball joint spot-welded to the control arm. The weld must be cut before attempting to remove the ball joint.

Removal

1. Assemble the ball joint press over the control arm as shown. Select the correct size receiving tube, and position it under the vehicle ball joint.
2. Tighten the forcing screw until the receiving tube contacts the control arm. Check the alignment of all tooling and components, and continue tightening the forcing screw until the ball joint is removed.

Installation

1. Clean the control arm and coat the I.D. with a suitable lubricant.
2. Insert the replacement ball joint as straight as possible into the vehicle control arm.
3. Assemble the ball joint press components as shown. Position the receiving tube, and tighten the forcing screw. Check the alignment of all tooling and components, and continue tightening the forcing screw until the ball joint is firmly seated.

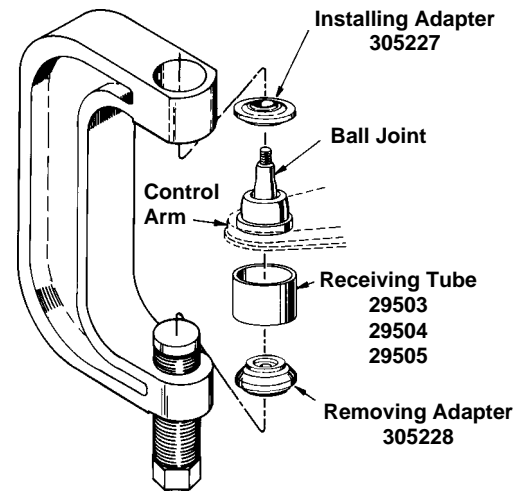

Removal

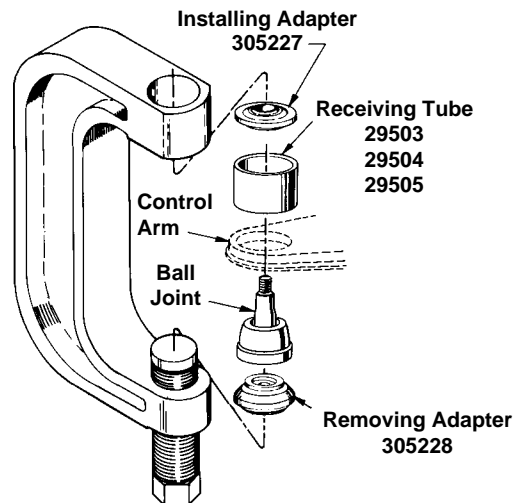

Installation

Dana 44 Axles

Application : Upper and lower ball joints on 1967–current 4WD vehicles with Dana 44 axles.

Removal

1. Remove the knuckle assembly from the vehicle according to the instructions in the service manual.

Note:

- It may be necessary to remove the steering arm before servicing the upper ball joint on left hand knuckle.
 - The lower ball joint must be removed before any service can be performed on the upper ball joint.
2. Remove the lower ball joint snap ring.
 3. Assemble the ball joint press over the ball joint as shown in Figure 3.
 4. Turn the forcing screw until it meets the ball joint. Check the alignment of all components. Tighten the forcing screw until the ball joint is removed.
 5. Repeat Steps 3 & 4 to remove the upper ball joint.

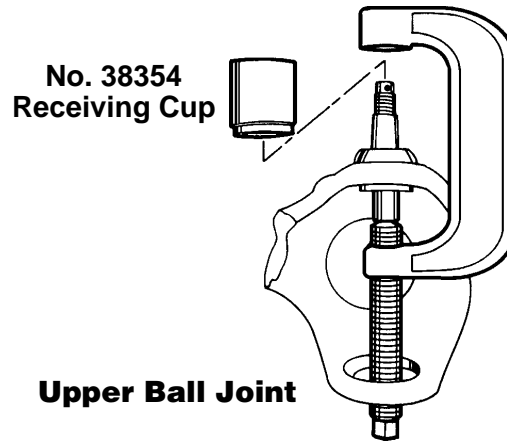
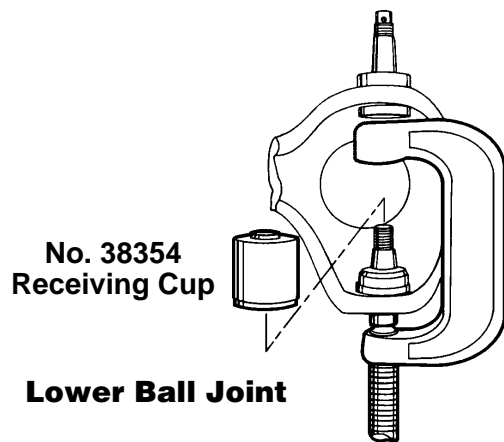

Installation

Note: The lower ball joint must be installed before the upper ball joint.

1. Clean the knuckle and coat it with a suitable lubricant.
2. Assemble the ball joint into the knuckle.
3. Assemble the ball joint press components as shown. Check the alignment of all components. Tighten the forcing screw until the ball joint is firmly seated.
4. Install the snap ring on the lower ball joint.
5. Repeat Steps 1-3 to install the upper ball joint.
6. Install the knuckle assembly to the vehicle according to the vehicle service manual procedures.

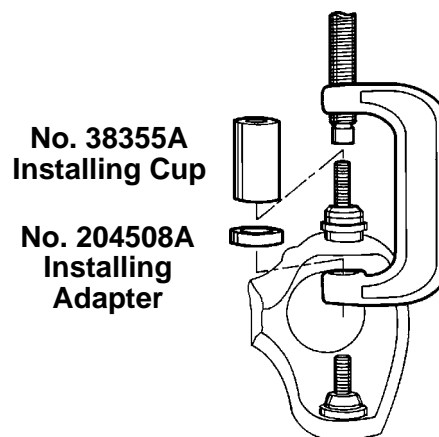
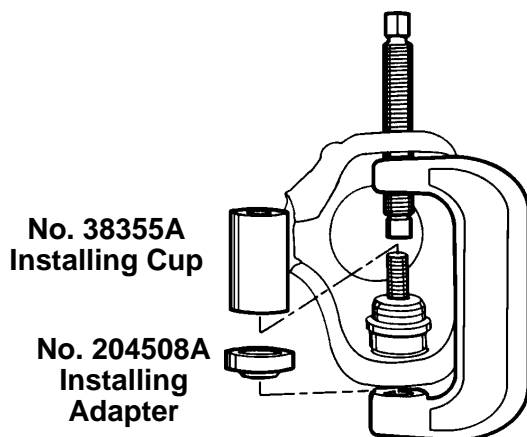

Application : 1996–newer GM 4WD 1/2-Ton and 3/4-Ton Pickups, Suburbans, Yukons, Tahoes

1. Position the tools as shown to remove or install the lower ball joint.

Note for Installation: Clean the control arm or knuckle, and coat the I.D. with a suitable lubricant.

2. Tighten the forcing screw until it meets the cup, and check the alignment of all tooling and components. Continue tightening the forcing screw until the ball joint is removed or installed.

Removing the Lower Ball Joint

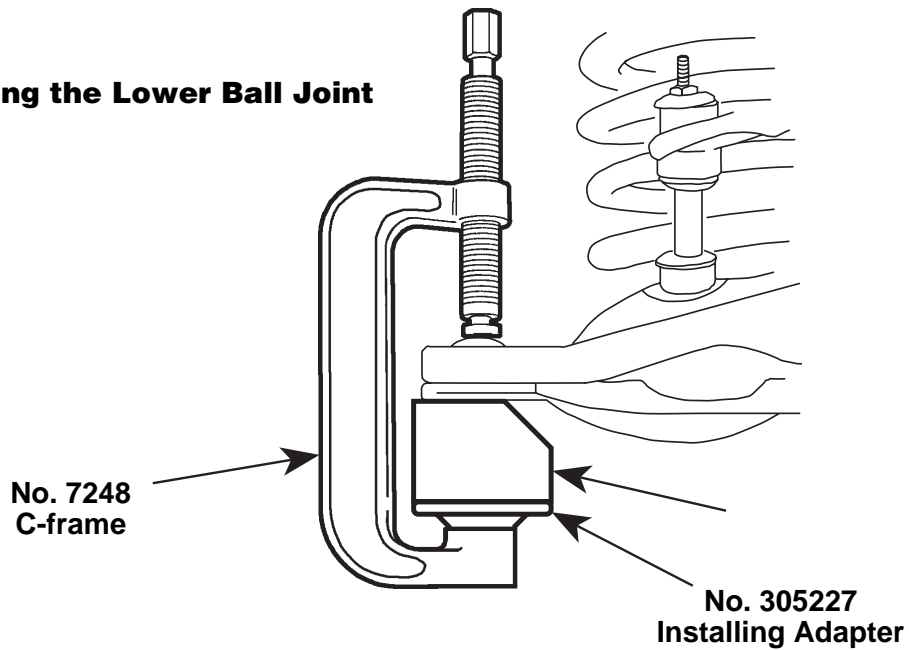

Installing the Lower Ball Joint

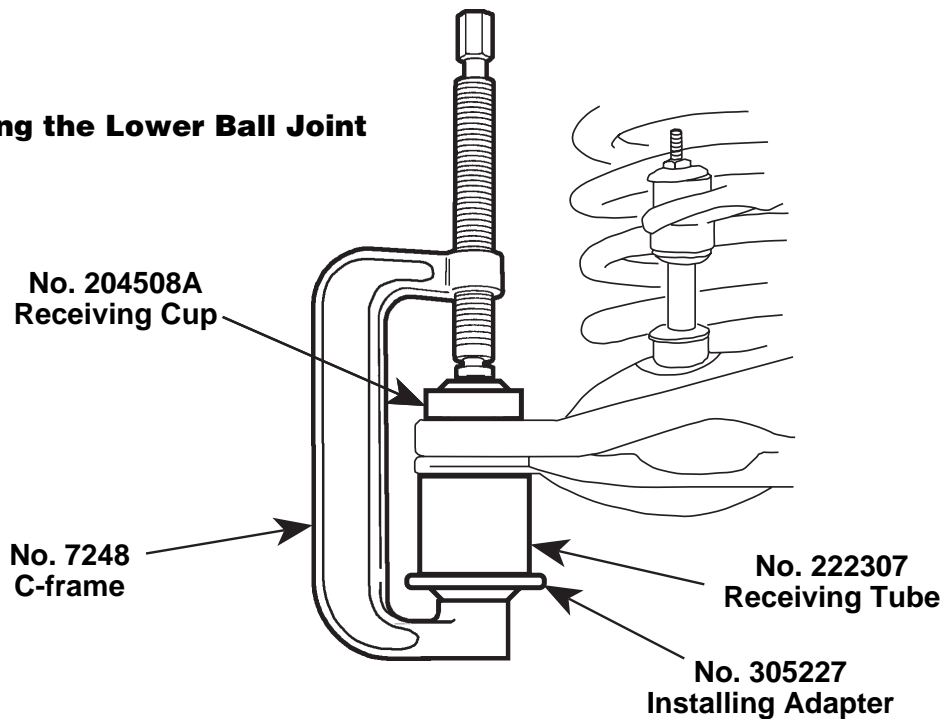

Ford 2WD Van

Application : Upper and lower ball joints on 1992–97 Ford 3/4-Ton and 1-Ton 2WD Vans

1. Position the tools as shown to remove or install the upper or lower ball joint. **Note for Installation:** Clean the control arm or knuckle, and coat the I.D. with a suitable lubricant.
2. Tighten the forcing screw until it meets the cup, and check the alignment of all tooling and components. Continue tightening the forcing screw until the ball joint is removed or installed.

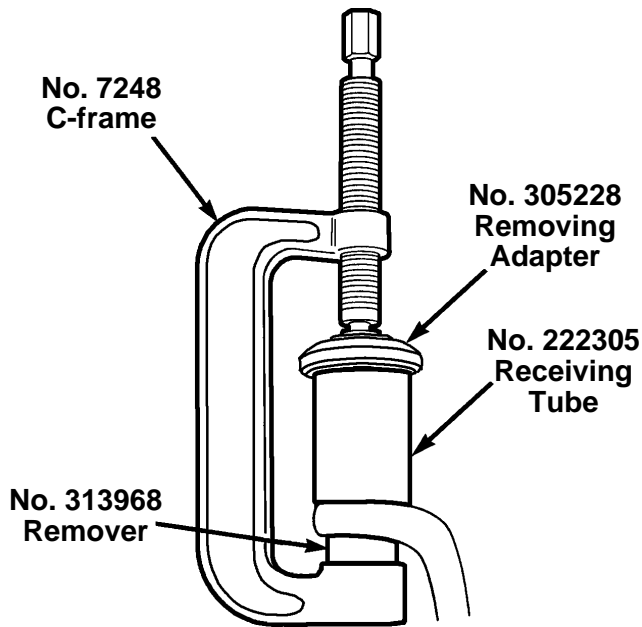

Removing the Upper Ball Joint

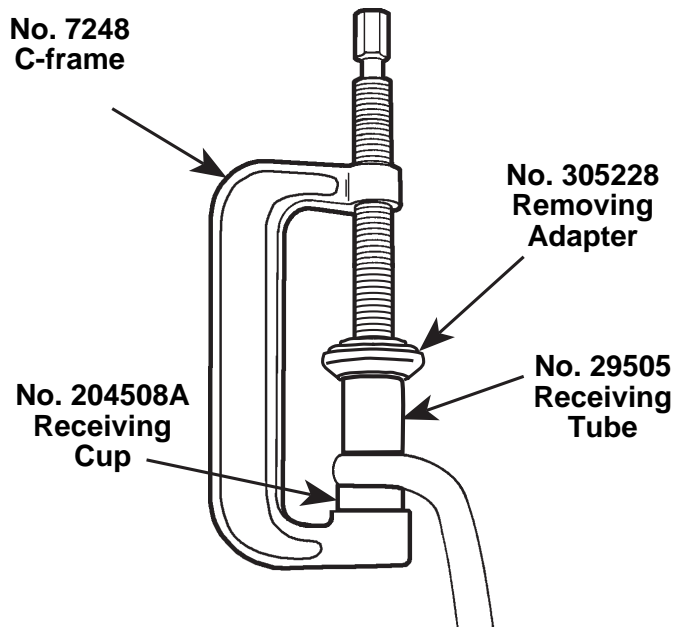

Installing the Upper Ball Joint

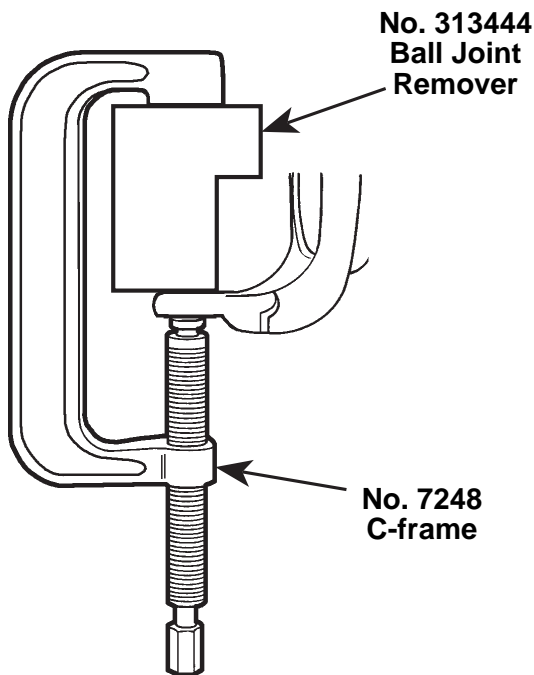

6 Removing the Lower Ball Joint

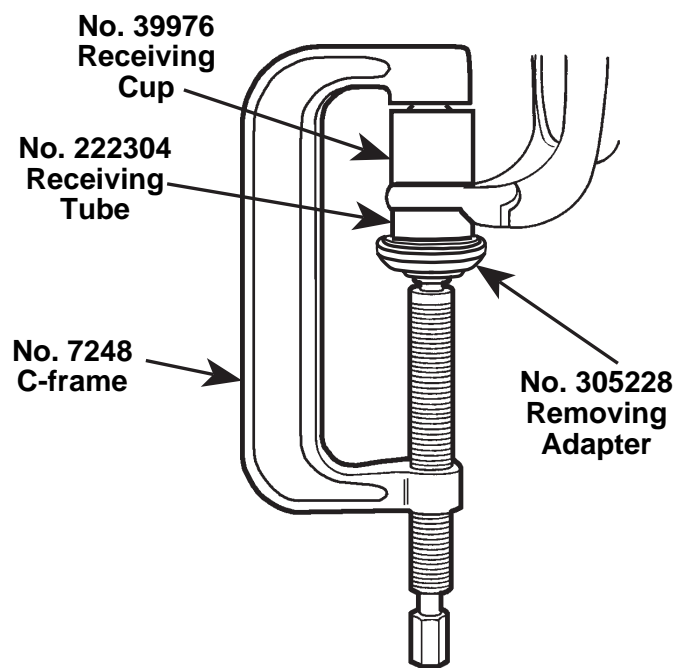

Installing the Lower Ball Joint

Dodge / Jeep 4WD

Application : Upper and lower ball joints on 1993–04 Grand Cherokee; 1994–01 Dodge Ram 4WD 1/2-Ton Pickup; 1984–89 Jeep Wagoneer, Cherokee, Comanche; 1987–98 Wrangler

1. Position the tools as shown to remove or install the upper or lower ball joint.

Note for Installation: Clean the control arm, and coat the I.D. with a suitable lubricant.

2. Tighten the forcing screw until it meets the cup, and check the alignment of all tooling and components. Continue tightening the forcing screw until the ball joint is removed or installed.

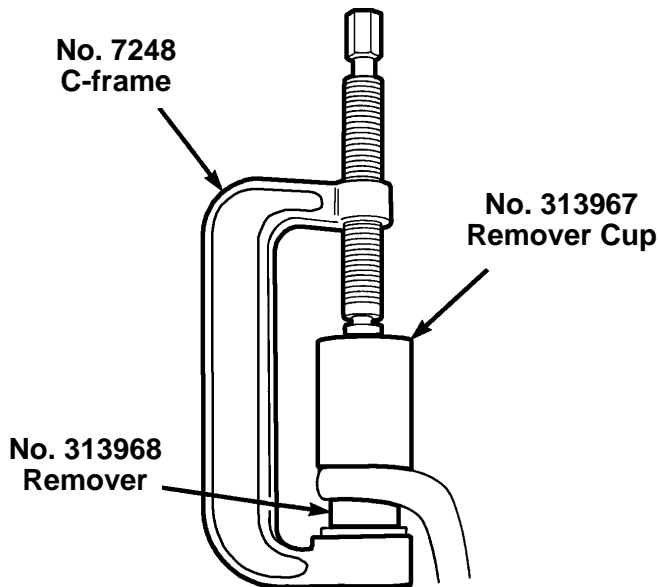

Removing the Upper Ball Joint

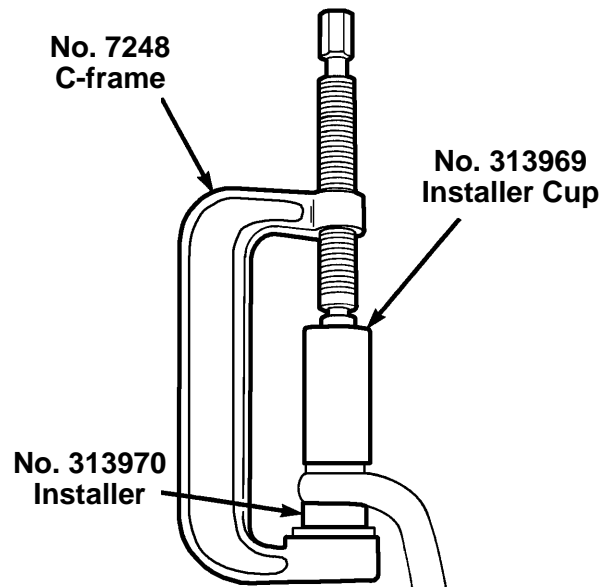

Installing the Upper Ball Joint

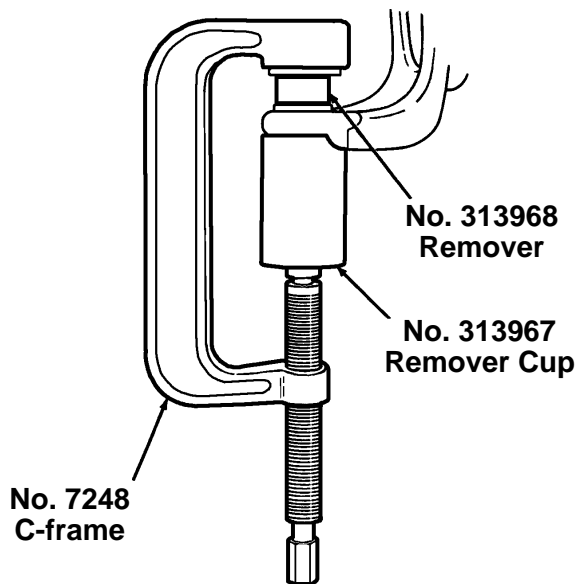

Removing the Lower Ball Joint

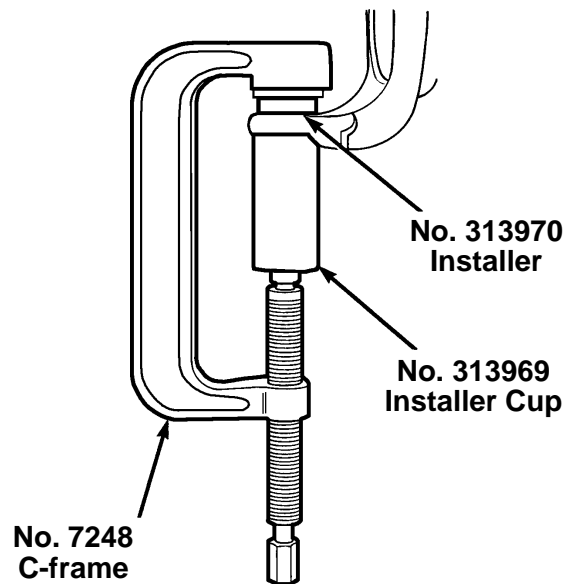

Installing the Lower Ball Joint

Honda

Application : Lower ball joints on 1986–97 Accord, 1988–00 Civic, 1988–91 CRX, 1993–99 del Sol, and 1983–98 Prelude

Removal

1. Assemble the ball joint press over the control arm as shown in Figure 1.
2. Tighten the forcing screw until the removing adapter contacts the control arm. Check the alignment of all tooling and components, and continue tightening the forcing screw until the ball joint is removed.

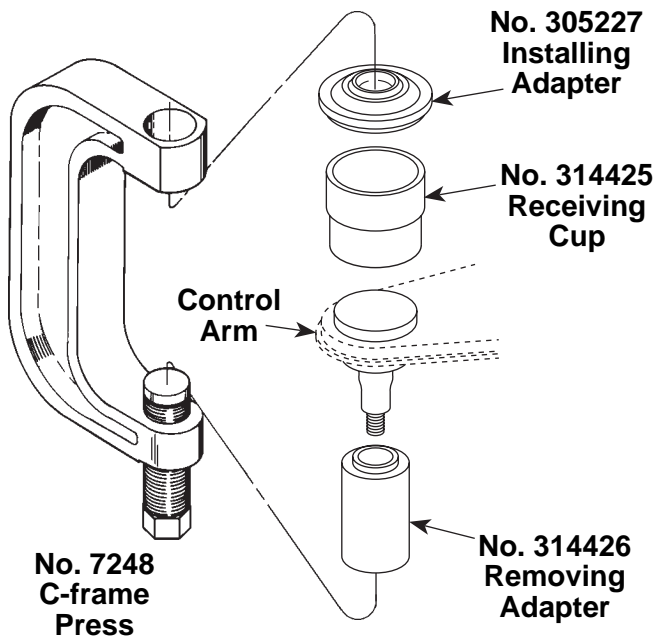

Figure 1
1986-89 Accord
1988-00 Civic
1988-91 CRX
1993-99 del Sol
1983-98 Prelude

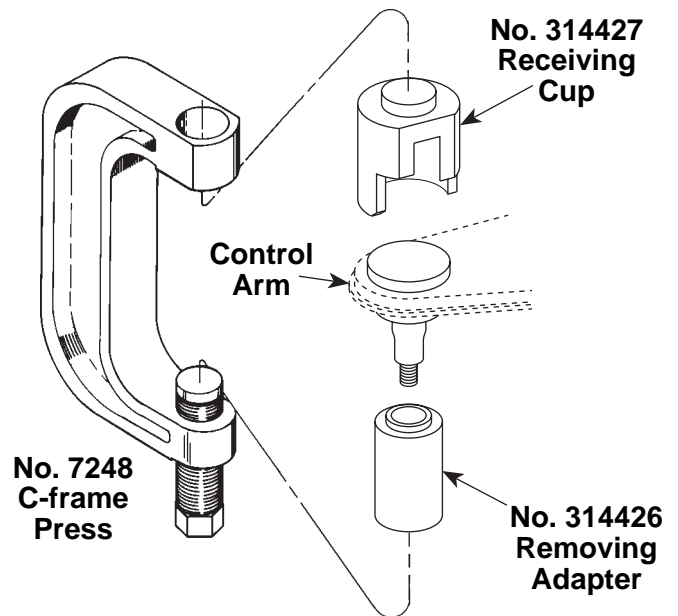

Figure 1
1990-97 Accord

Installation

1. Clean the control arm and coat the I.D. with a suitable lubricant.
2. Insert the replacement ball joint as straight as possible into the vehicle control arm.
3. Assemble the ball joint press components as shown in Figure 2, and tighten the forcing screw. Check the alignment of all tooling and components, and continue tightening the forcing screw until the ball joint is firmly seated.

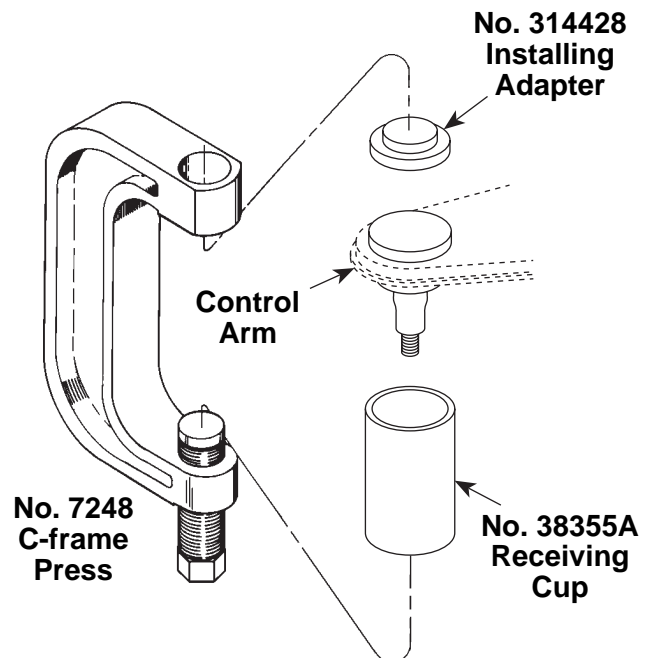

Figure 2

Honda

Application : Lower ball joints on 1999-2004 Odyssey vans

Removal

1. Remove the ball joint dust boot.
2. Assemble the ball joint press over the control arm as shown in Figure 1.
3. Tighten the forcing screw until the removing adapter contacts the control arm. Check the alignment of all tooling and components, and continue tightening the forcing screw until the ball joint is removed.

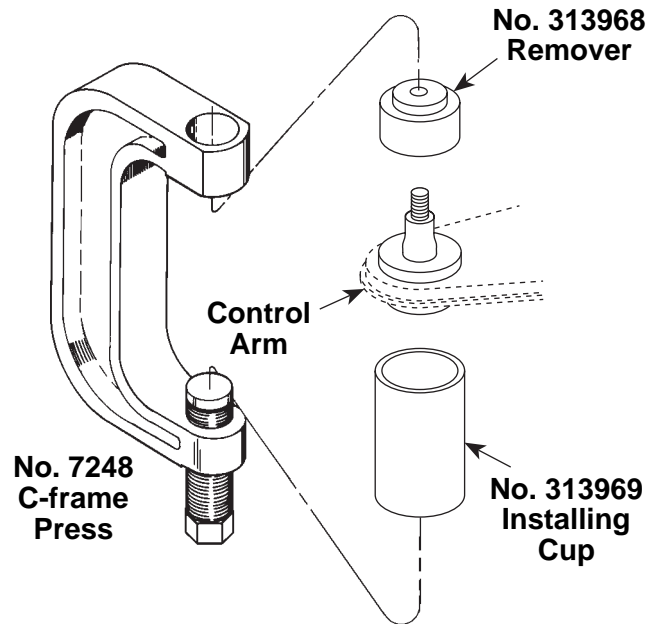

Figure 1

Installation

1. Clean the control arm and coat the I.D. with a suitable lubricant.
2. Insert the replacement ball joint as straight as possible into the vehicle control arm.
3. Assemble the ball joint press components as shown in Figure 2, and tighten the forcing screw. Check the alignment of all tooling and components, and continue tightening the forcing screw until the ball joint is firmly seated.
4. Install the ball joint dust boot.

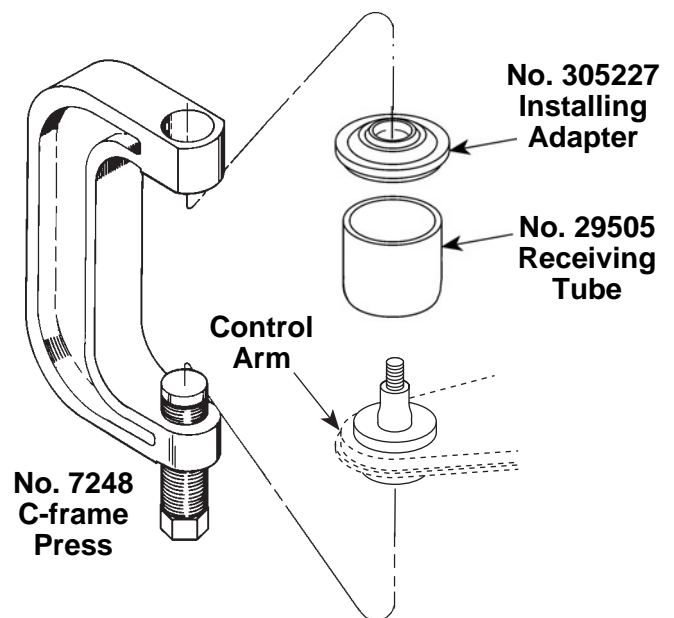

Figure 2