

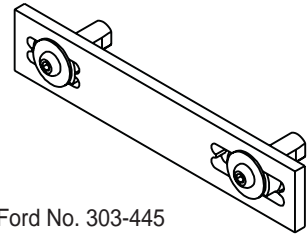

Ford V8 Cam Tools Operating Instructions

<u>Cam Tool</u>	<u>Part No.</u>
Camshaft Positioning Tool	525216
Camshaft Holding Tool	525217
Secondary Timing Chain Tensioner Tool	525218
Crankshaft Positioning Tool	525219



Similar to Ford No. 303-445

No. 525216 Camshaft Positioning Tool

Application : 1993–2004 Ford 4.6L 4-valve V8, VIN Code V engines
1993–1998 Lincoln Mark series
1995–2002 Lincoln Continental
1996–2001 Ford Mustang
2003–2004 Mercury Marauder

CAUTION : To prevent damage to valves and pistons, **DO NOT** rotate the crankshaft and/or camshaft(s) when removing timing chain(s) and installing cylinder heads. Because this is not a free-wheeling engine, if it has "jumped time," there will be damage to valves and/or pistons which will require the removal of the cylinder heads.

Note : This tool must be used with No. 525217 Ford Camshaft Holding Tool.

1. Rotate the engine to the Top Dead Center No. 1 (TDC #1) cylinder.
2. Install No. 525216 Camshaft Positioning Tool into the rear "D Slot" on the camshaft.

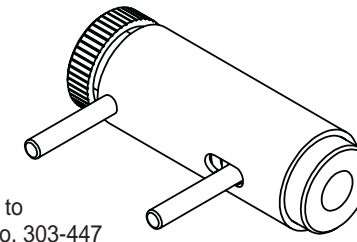
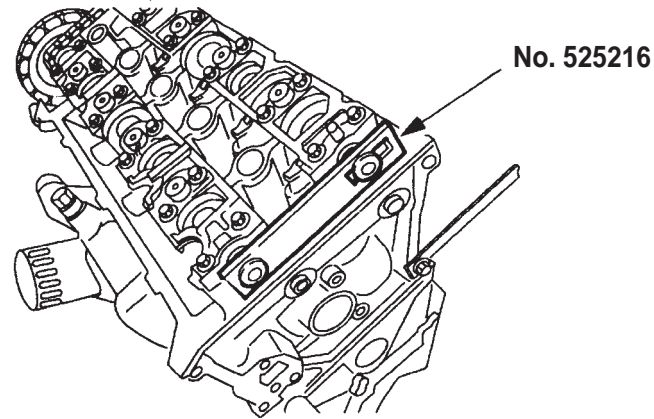

Similar to Ford No. 303-447

No. 525218 Secondary Timing Chain Tensioner Tool

Application : 1993–1997 Ford 4.6L 4-valve V8 in Lincoln Mark series

CAUTION : To prevent damage to valves and pistons, **DO NOT** rotate the crankshaft and/or camshaft(s) when removing timing chain(s) and installing cylinder heads. Because this is not a free-wheeling engine, if it has "jumped time," there will be damage to valves and/or pistons which will require the removal of the cylinder heads.

1. Insert No. 525218 Secondary Timing Chain Tensioner Tool between the upper and lower rubbing blocks of the chain tensioner.
2. Rotate the knob on top of the tool until spring pressure is applied to the tensioner, and the knob on the tool rotates freely.

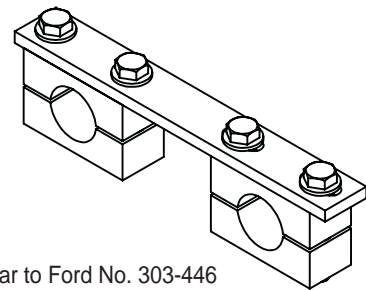
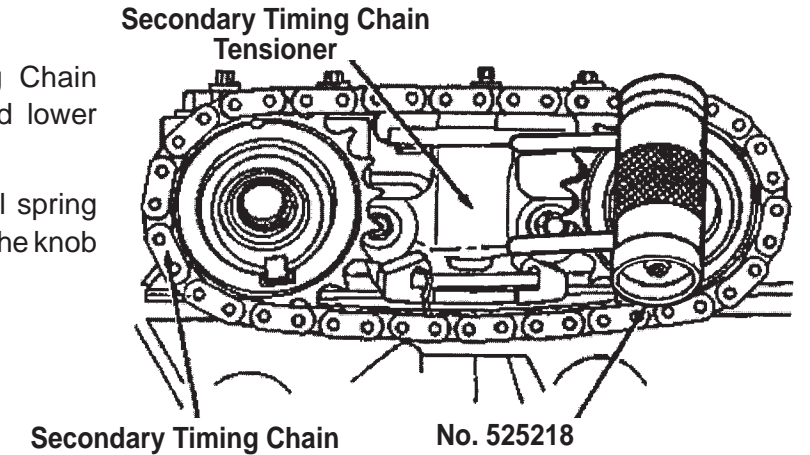

Similar to Ford No. 303-446

No. 525217 Camshaft Holding Tool

Application : 1993–1998 Lincoln Mark series
1995–2002 Lincoln Continental
1996–2004 Ford Mustang
2003–2004 Mercury Marauder
2003–2004 Ford 4.6L 4-valve V8, VIN Code H, R, V, Y
2003–2004 Lincoln Aviator

CAUTION : To prevent damage to valves and pistons, **DO NOT** rotate the crankshaft and/or camshaft(s) when removing timing chain(s) and installing cylinder heads. Because this is not a free-wheeling engine, if it has "jumped time," there will be damage to valves and/or pistons which will require the removal of the cylinder heads.

1. Rotate the engine to the Top Dead Center No. 1 (TDC #1) cylinder.
2. Install No. 525217 Camshaft Holding Tool onto the machined centers of both the intake and exhaust camshafts. Evenly torque the four clamping bolts on the tool to 15 ft-lbs (20 N•m).

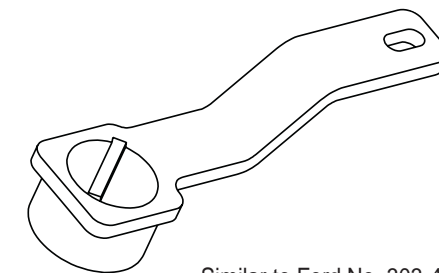
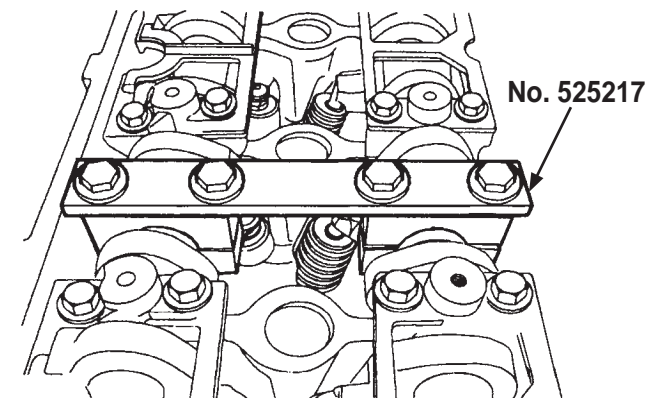

Similar to Ford No. 303-448

No. 525219 Crankshaft Positioning Tool

Application : 1993–newer 4.2L and 4.6L 2-valve engines
1993–newer 4.6L 4-valve engines
1993–newer 5.4L and 6.8L V8 engines

CAUTION : To prevent damage to valves and pistons, **DO NOT** rotate the crankshaft and/or camshaft(s) when removing timing chain(s) and installing cylinder heads. Because this is not a free-wheeling engine, if it has "jumped time," there will be damage to valves and/or pistons which will require the removal of the cylinder heads.

1. Install No. 525219 Crankshaft Positioning Tool over the crankshaft and engine front cover alignment dowel. This positions the crankshaft at top dead center (TDC) for correct timing chain installation.

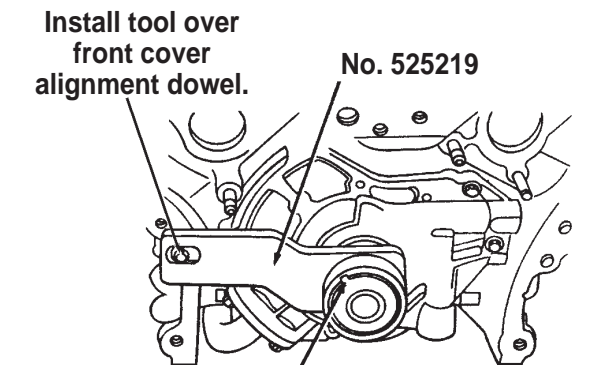

Align crankshaft woodruff key with keyway on tool.

CAUTION: To prevent personal injury, wear eye protection that meets ANSI Z87.1 and OSHA standards.

CAUTION: To prevent personal injury, wear eye protection that meets ANSI Z87.1 and OSHA standards.