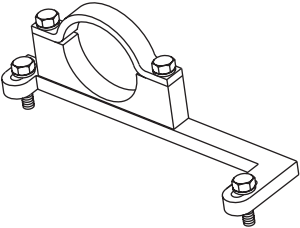
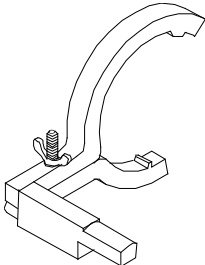
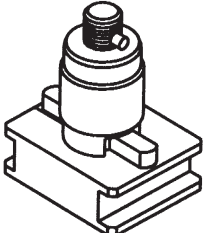
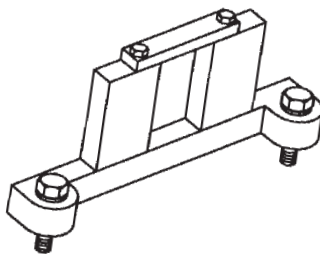
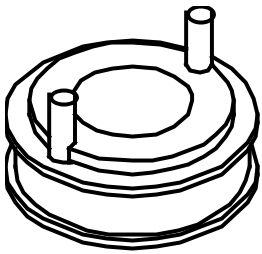
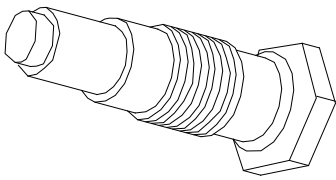
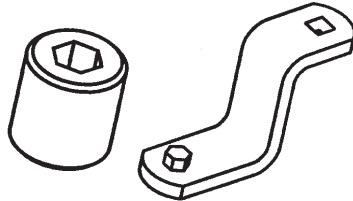

Parts List &
Operating Instructions
for: 6488

Ford 4.0L SOHC V6 Cam Tools

 <p>6478</p>	 <p>6479</p>
 <p>6480</p>	 <p>6481</p>
 <p>6482</p>	 <p>6484</p>
 <p>6485</p>	

Parts List & Operating Instructions

Ford Tool Application Chart

Year	Make & Model	Engine	Tool Description	OTC Part No.	Ford No. American Part No.	Ford Global Part No.
1995-1997	Aerostar	3.0L V6	Cam Sensor Synch Tool	6472 (511539)	T95T-12200-A	303-529
1996-1998	Aerostar	4.0L V6	Cam Sensor Synch Tool	6472 (511539)	T95T-12200-A	303-529
1994-2002	Contour	2.0L 4 cyl. DOHC Zetec	Cam Alignment Tool	6474 (511541)	T94P-6256-CH	303-465
1997-2002	Contour	2.0L 4 cyl. DOHC Zetec	Crankshaft TDC Timing Pin	6475 (511542)	T97P-6000-A	303-574
1991-1998	Crown Victoria	4.6L 2V V8	Cam Positioning Tool	6009 (511532)	T91P-6256-A	303-380
1992-1998	Crown Victoria	4.6L 2V V8	Cam Positioning Tool	6020 (511555)	T92P-6256-A	303-413
1997-2002	Econoline	4.2L V6	Cam Sensor Synch Tool	6469 (511536)	T96T-12200-A	303-562
1997-1998	Econoline	4.6L & 5.4L V8, 6.8L V10	Cam Positioning Tool	6009 (511532)	T91P-6256-A	303-380
			Cam Positioning Tool	6020 (511555)	T92P-6256-A	303-413
1997-2002	Econoline	4.6L & 5.4L	Cam Positioning Tool Set	6476 (511543 & -4)	T96T-6256-AR	303-S568
1997-2002	Econoline	5.4L V8	Cam Holding Tool	6477 (511545)	T96T-6256-B	303-557
1997-2002	Econoline	6.8L V10	Cam Positioning Tool Set	6476 (511543 & -4)	T96T-6256-AR	303-S568
			Cam Holding Tool	6477 (511545)	T96T-6256-B	303-557
1997-2002	Econoline	Windsor V8	Cam Holding Tool	6477 (511545)	T96T-6256-B	303-557
1997-1998	Expedition	5.4L V8	Cam Positioning Tool	6009 (511532)	T91P-6256-A	303-380
			Cam Positioning Tool	6020 (511555)	T92P-6256-A	303-413
1997-2002	Expedition	5.4L V8	Cam Positioning Tool Set	6476 (511543 & -4)	T96T-6256-AR	303-S568
			Cam Holding Tool	6477 (511545)	T96T-6256-B	303-557
1996-1998	Explorer	4.0L V6	Cam Sensor Synch Tool	6472 (511539)	T95T-12200-A	303-529
1997-2002	Explorer	4.0L SOHC V6	Cam Gear Holding Tool	6478 (511546)	T97T-6256-B	303-564
			Crankshaft Holding Tool	6479 (511547)	T97T-6303-A	303-573
			Cam Holding Tool Adapter	6480 (511548)	T97T-6256-D	303-576
			Cam Holding Tool	6481 (511549)	T97T-6256-C	303-577
			Cam Gear Holding Tool Adapter	6482 (511550)	T97T-6256-A	303-578
			Timing Chain Tensioner Tool	6484 (511552)	T97T-6K254-A	303-571
			Cam Gear Bolt Socket & Ext.	6485 (511553 & -4)	T97T-6256-F, -G	303-565, -575
1999-2002	Explorer	4.0L Push Rod V6	Cam Sensor Synch Tool	6483 (511551)		303-638
1996-1998	Explorer	5.0L V8	Cam Sensor Synch Tool	6469 (511536)	T96T-12200-A	303-562
1999-2002	Explorer	5.0L V8	Cam Sensor Synch Tool	6470 (511537)		303-630
1997-2002	F-Series Truck	4.2L V6	Cam Sensor Synch Tool	6469 (511536)	T96T-12200-A	303-562
1997-1998	F-Series Truck	4.6L & 5.4L V8	Cam Positioning Tool	6009 (511532)	T91P-6256-A	303-380
			Cam Positioning Tool	6020 (511555)	T92P-6256-A	303-413
1997-2002	F-Series Truck	4.6L & 5.4L	Cam Positioning Tool Set	6476 (511543 & -4)	T96T-6256-AR	303-S568
1997-2002	F-Series Truck	5.4L V8	Cam Holding Tool	6477 (511545)	T96T-6256-B	303-557
1997-2002	F-Series Truck	Windsor V8	Cam Holding Tool	6477 (511545)	T96T-6256-B	303-557
1994-1995	Mustang	3.8L V6	Cam Sensor Synch Tool	6467 (511534)	T89P-12200-A	303-358
1996-1998	Mustang	3.8L V6	Cam Sensor Synch Tool	6469 (511536)	T96T-12200-A	303-562
1999-2002	Mustang	3.8L V6	Cam Sensor Synch Tool	6470 (511537)		303-630
1993-1997	Probe	2.0L 4 cyl.	Cam Pulley Holding Tool	6468 (511535)	T92C-6256-AH	303-398
1989-1997	Ranger	2.3L, 4 cyl. dual plug	Crankshaft Sensor Positioner	6466 (511533)	T89P-6316-A	303-354
1995-1997	Ranger	3.0L V6	Cam Sensor Synch Tool	6472 (511539)	T95T-12200-A	303-529
1998-2002	Ranger	3.0L V6	Cam Sensor Synch Tool	6473 (511540)		303-589
1996-1998	Ranger	4.0L V6	Cam Sensor Synch Tool	6472 (511539)	T95T-12200-A	303-529
1993-1995	Taurus	3.0L V6	Cam Sensor Synch Tool	6471 (511538)	T93P-12200-A	303-453
1996-1997	Taurus	3.0L V6 2-valve	Cam Sensor Synch Tool	6472 (511539)	T95T-12200-A	303-529
1998-2002	Taurus	3.0L V6	Cam Sensor Synch Tool	6473 (511540)		303-589
1989-1995	Thunderbird	Supercharged 3.8L V6	Cam Sensor Synch Tool	6467 (511534)	T89P-12200-A	303-358
1990-1995	Thunderbird	3.8L V6	Cam Sensor Synch Tool	6467 (511534)	T89P-12200-A	303-358
1997	Thunderbird	3.8L V6	Cam Sensor Synch Tool	6469 (511536)	T96T-12200-A	303-562
1995-1997	Windstar	3.0L V6	Cam Sensor Synch Tool	6472 (511539)	T95T-12200-A	303-529
1998-2002	Windstar	3.0L V6	Cam Sensor Synch Tool	6473 (511540)		303-589
1995	Windstar	3.8L V6	Cam Sensor Synch Tool	6467 (511534)	T89P-12200-A	303-358
1996-1998	Windstar	3.8L V6	Cam Sensor Synch Tool	6469 (511536)	T96T-12200-A	303-562
1999-2002	Windstar	3.8L V6	Cam Sensor Synch Tool	6470 (511537)		303-630
1998	Lincoln Navigator	5.4L V8	Cam Positioning Tool	6009 (511532)	T91P-6256-A	303-380
			Cam Positioning Tool	6020 (511555)	T92P-6256-A	303-413
1998-2002	Lincoln Navigator	5.4L V8	Cam Positioning Tool Set	6476 (511543 & -4)	T96T-6256-AR	303-S568
			Cam Holding Tool	6477 (511545)	T96T-6256-B	303-557
1989-1995	Cougar	Supercharged 3.8L V6	Cam Sensor Synch Tool	6467 (511534)	T89P-12200-A	303-358
1990-1995	Cougar	3.8L V6	Cam Sensor Synch Tool	6467 (511534)	T89P-12200-A	303-358
1997	Cougar	3.8L V6	Cam Sensor Synch Tool	6469 (511536)	T96T-12200-A	303-562
1991-1998	Grand Marquis	4.6L 2V V8	Cam Positioning Tool	6009 (511532)	T91P-6256-A	303-380
1992-1998	Grand Marquis	4.6L 2V V8	Cam Positioning Tool	6020 (511555)	T92P-6256-A	303-413
1997-2002	Mountaineer	4.0L SOHC V6	Cam Gear Holding Tool	6478 (511546)	T97T-6256-B	303-564
			Crankshaft Holding Tool	6479 (511547)	T97T-6303-A	303-573
			Cam Holding Tool Adapter	6480 (511548)	T97T-6256-D	303-576
			Cam Holding Tool	6481 (511549)	T97T-6256-C	303-577
			Cam Gear Holding Tool Adapter	6482 (511550)	T97T-6256-A	303-578
			Timing Chain Tensioner Tool	6484 (511552)	T97T-6K254-A	303-571
			Cam Gear Bolt Socket & Ext.	6485 (511553 & -4)	T97T-6256-F, -G	303-565, -575
1999-2002	Mountaineer	4.0L Push Rod V6	Cam Sensor Synch Tool	6483 (511551)		303-638
1996-1998	Mountaineer	5.0L V8	Cam Sensor Synch Tool	6469 (511536)	T96T-12200-A	303-562
1999-2002	Mountaineer	5.0L V8	Cam Sensor Synch Tool	6470 (511537)		303-630
1994-2002	Mystique	2.0L 4 cyl. DOHC Zetec	Cam Alignment Tool	6474 (511541)	T94P-6256-CH	303-465
1997-2002	Mystique	2.0L 4 cyl. DOHC Zetec	Crankshaft TDC Timing Pin	6475 (511542)	T97P-6000-A	303-574
1993-1995	Sable	3.0L V6	Cam Sensor Synch Tool	6471 (511538)	T93P-12200-A	303-453
1996-1997	Sable	3.0L V6 2-valve	Cam Sensor Synch Tool	6472 (511539)	T95T-12200-A	303-529
1998-2002	Sable	3.0L V6	Cam Sensor Synch Tool	6473 (511540)		303-589

6478 Ford Camshaft Gear Holding Tool

Application: 1997 – 2002 4.0L SOHC V6 Ford Explorer, Mercury Mountaineer

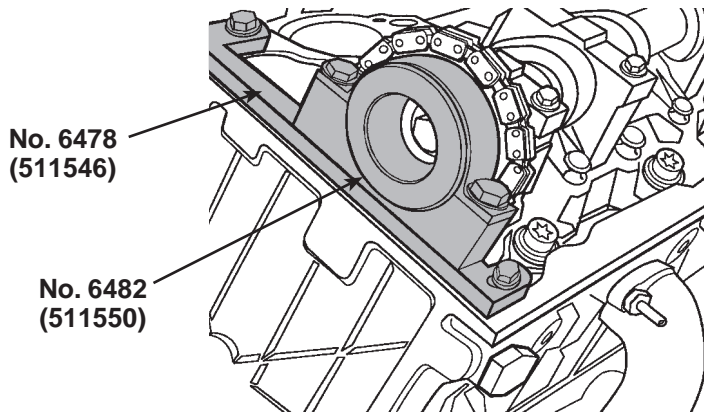
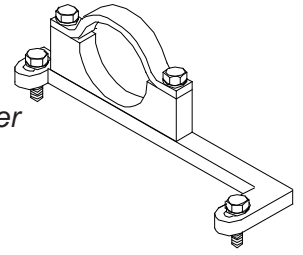

NOTE: Same as Ford No. 303-564 (T97T-6256-B).

Note: This tool is used with No. 6482 (511550) Ford Camshaft Gear Holding Tool Adapter.

1. Install tool Nos. 6478 (511546) and 6482 (511550) on the camshaft as shown.
2. Secure tool No. 6478 (511546) to the cylinder head.
3. Service the timing chain as required according to instructions in the vehicle service manual.
4. Torque fasteners to factory specifications.



WARNING: Wear eye protection that meets ANSI Z87.1 and OSHA standards.

6479 Ford Crankshaft Holding Tool

Application: 1997 – 2002 4.0L SOHC V6 Ford Explorer, Mercury Mountaineer

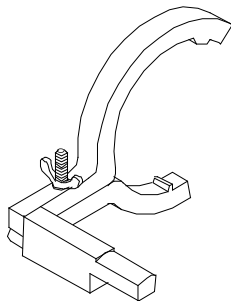

NOTE: Same as Ford No. 303-573 (T97T-6303-A).

1. Install tool No. 6479 (511547) on the crankshaft damper.
2. Rotate the engine counterclockwise (CCW) until the tool stops against the engine block.
3. Service the timing chain as required according to instructions in the vehicle service manual.
4. Torque fasteners to factory specifications.

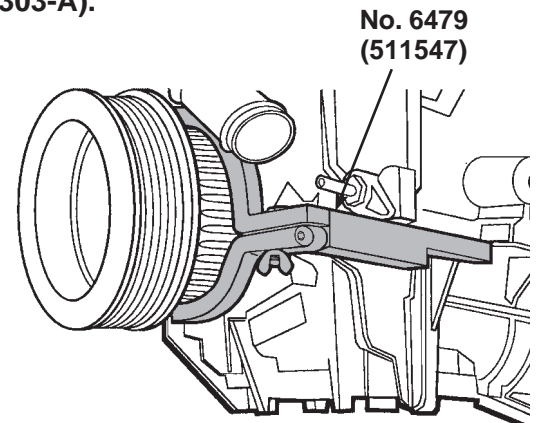

WARNING: Wear eye protection that meets ANSI Z87.1 and OSHA standards.

6480 Ford Camshaft Holding Tool Adapter

Application: 1997 – 2002 4.0L SOHC V6 Ford Explorer, Mercury Mountaineer

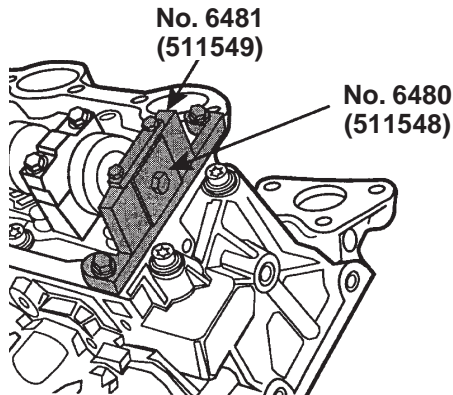

NOTE: Same as Ford No. 303-576 (T97T-6256-D).

Note: This tool is used with No. 6481 (511549) Ford Camshaft Holding Tool.

1. Install tool Nos. 6480 (511548) and 6481 (511549) on the camshaft as shown.
2. Secure tool No. 6481 (511549) to the cylinder head.
3. Service the timing chain as required according to instructions in the vehicle service manual.
4. Torque fasteners to factory specifications.

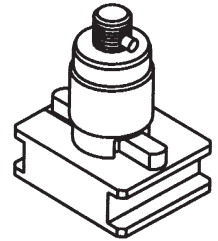

WARNING: Wear eye protection that meets ANSI Z87.1 and OSHA standards.

6481 Ford Camshaft Holding Tool

Application: 1997 – 2002 4.0L SOHC V6 Ford Explorer, Mercury Mountaineer

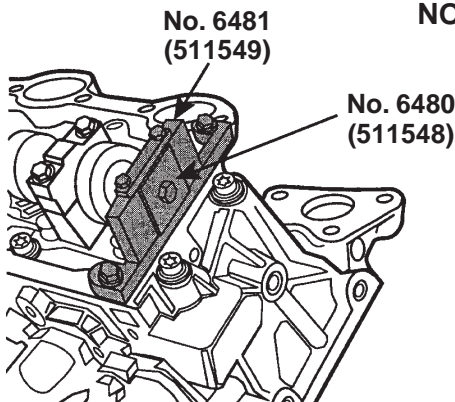

NOTE: Same as Ford No. 303-577 (T97T-6256-C).

Note: This tool is used with No. 6480 (511548) Ford Camshaft Holding Tool Adapter.

1. Install tool Nos. 6480 (511548) and 6481 (511549) on the camshaft as shown.
2. Secure tool No. 6481 (511549) to the cylinder head.
3. Service the timing chain as required according to instructions in the vehicle service manual.
4. Torque fasteners to factory specifications.

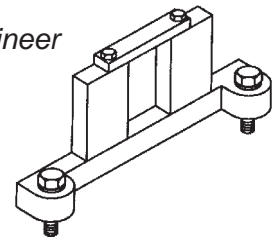

WARNING: Wear eye protection that meets ANSI Z87.1 and OSHA standards.

6482 Ford Camshaft Gear Holding Tool Adapter

Application: 1997 – 2002 4.0L SOHC V6 Ford Explorer, Mercury Mountaineer

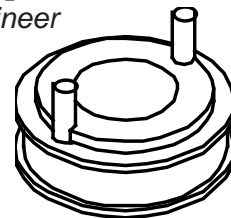

NOTE: Same as Ford No. 303-578 (T97T-6256-A).

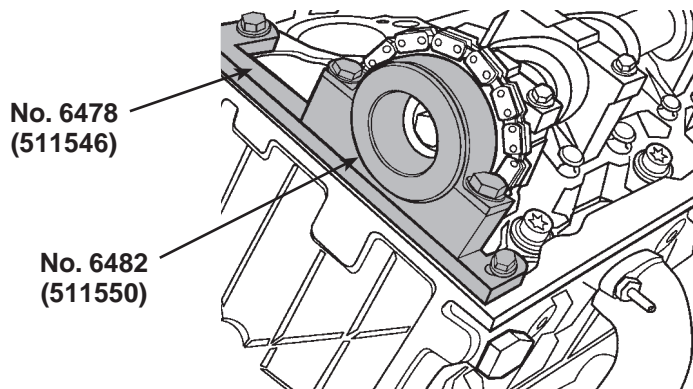

No. 6478
(511546)

No. 6482
(511550)



WARNING: Wear eye protection that meets ANSI Z87.1 and OSHA standards.

Note: This tool is used with No. 6478 (511546) Ford Camshaft Gear Holding Tool .

1. Install tool Nos. 6478 (511546) and 6482 (511550) on the camshaft as shown.
2. Secure tool No. 6478 (511546) to the cylinder head.
3. Service the timing chain as required according to instructions in the vehicle service manual.
4. Torque fasteners according to factory specifications.

6484 Ford Timing Chain Tensioner Tool

Application: 1997 – 2002 4.0L SOHC V6 Ford Explorer, Mercury Mountaineer

NOTE: Same as Ford No. 303-571 (T97T-6K254-A).

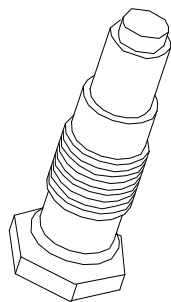

1. Remove the hydraulic chain tensioner from the engine.
2. Install tool No. 6484 (511552) into the engine to hold pressure on the timing chain during the cam timing procedure.
3. Adjust camshaft timing according to instructions in the vehicle service manual.
4. Torque fasteners to factory specifications.

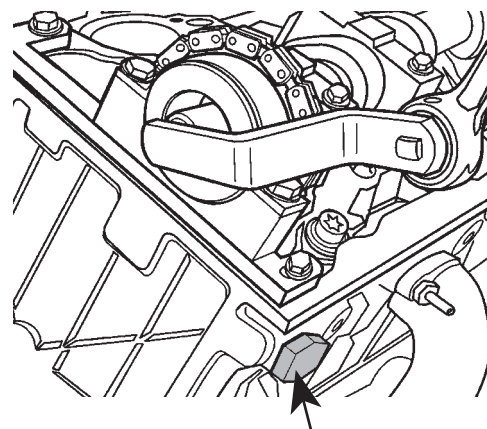

No. 6484
(511552)



WARNING: Wear eye protection that meets ANSI Z87.1 and OSHA standards.

6485 Ford Camshaft Gear Bolt Socket & Extension

Application: 1997 – 2002 4.0L SOHC V6 Ford Explorer, Mercury Mountaineer

NOTE: 511553 is the same as Ford No. 303-565 (T97T-6256-G) and 511554 is the same as Ford No. 303-575 (T97T-6256-F).

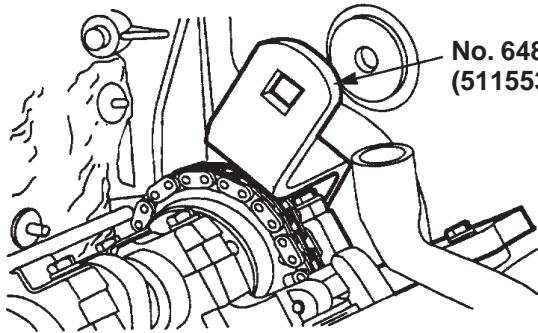

No. 6485
(511553 & 511554)

No. 511553
Camshaft Gear
Bolt Socket

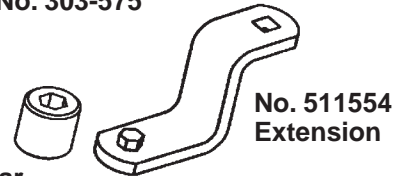

No. 511554
Extension

1. Assemble the No. 6485 (511553 & 511554) socket and extension on the camshaft gear bolt as shown.

Removal: Use a ratchet or breaker bar to loosen and remove the bolt from the camshaft.

Assembly: Use a torque wrench to tighten the bolt on the camshaft. Refer to the vehicle service manual for the correct torque specifications.



WARNING: Wear eye protection that meets ANSI Z87.1 and OSHA standards.