

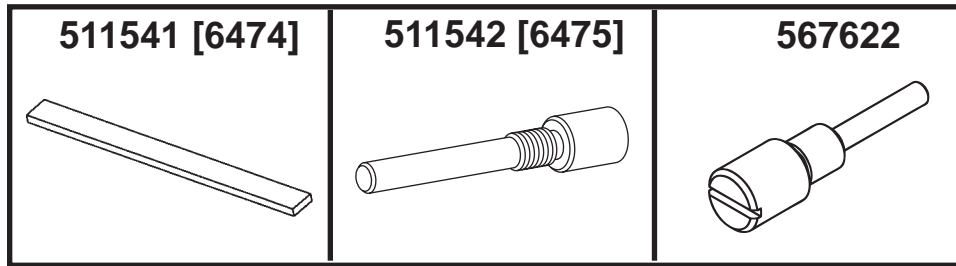

Parts List & Operating Instructions for No. 6486A Ford 2.0L, 2.3L, 2.5L Engine Cam Tool Kit



Ford Tool Application Chart						
Year	Model	Engine	Tool Description	Part No.	Ford American Part No.	Ford Global Part No.
1994-2002	Contour	2.0L 4 cyl. VIN 3	Cam Alignment Tool	6474 (511541)	T94P-6256-CH	303-465
1997-2002	Contour	2.0L 4 cyl. VIN 3	Crankshaft TDC Timing Pin	6475 (511542)	T97P-6000-A	303-574
1999-2002	Cougar	2.0L VIN 3	Cam Alignment Tool Crankshaft TDC Timing Pin	6474 (511541) 6475 (511542)	T94P-6256-CH T97P-6000-A	303-465 303-574
2012-2014	Edge	2.0L VIN 9	Cam Alignment Tool Crankshaft TDC Timing Pin	6474 (511541) 6475 (511542)	T94P-6256-CH T97P-6000-A	303-465 303-574
2012	Edge	2.0L	Crankshaft TDC Timing Pin	567622		303-507
2013-2014	Escape	2.0L VIN 9	Cam Alignment Tool Crankshaft TDC Timing Pin	6474 (511541) 6475 (511542)	T94P-6256-CH T97P-6000-A	303-465 303-574
2001-2004	Escape	2.0L VIN B	Cam Alignment Tool Crankshaft TDC Timing Pin	6474 (511541) 6475 (511542)	T94P-6256-CH T97P-6000-A	303-465 303-574
2005-2008	Escape	2.3L VIN Z	Cam Alignment Tool	6474 (511541)	T94P-6256-CH	303-465
2005-2008	Escape	2.3L	Crankshaft TDC Timing Pin	567622		303-507
2009-2014	Escape	2.5L VIN 7	Cam Alignment Tool	6474 (511541)	T94P-6256-CH	303-465
2009-2012	Escape	2.5L	Crankshaft TDC Timing Pin	567622		303-507
2005-2008	Escape Hybrid	2.3L VIN H	Cam Alignment Tool	6474 (511541)	T94P-6256-CH	303-465
2009-2012	Escape Hybrid	2.5L VIN 3	Cam Alignment Tool	6474 (511541)	T94P-6256-CH	303-465
2012-2014	Explorer	2.0L VIN 9	Cam Alignment Tool Crankshaft TDC Timing Pin	6474 (511541) 6475 (511542)	T94P-6256-CH T97P-6000-A	303-465 303-574
2012-2014	Focus	2.0L VIN 2	Cam Alignment Tool Crankshaft TDC Timing Pin	6474 (511541) 6475 (511542)	T94P-6256-CH T97P-6000-A	303-465 303-574
2000-2004	Focus	2.0L VIN 3	Cam Alignment Tool Crankshaft TDC Timing Pin	6474 (511541) 6475 (511542)	T94P-6256-CH T97P-6000-A	303-465 303-574
2002-2004	Focus	2.0L VIN 5	Cam Alignment Tool Crankshaft TDC Timing Pin	6474 (511541) 6475 (511542)	T94P-6256-CH T97P-6000-A	303-465 303-574
2005-2012	Focus	2.0L VIN N	Cam Alignment Tool	6474 (511541)	T94P-6256-CH	303-465
2005-2011	Focus	2.0L VIN N	Crankshaft TDC Timing Pin	6475 (511542)	T97P-6000-A	303-574
2005-2012	Focus	2.0L	Crankshaft TDC Timing Pin	567622		303-507
2003-2007	Focus	2.3L VIN Z	Cam Alignment Tool	6474 (511541)	T94P-6256-CH	303-465
2005-2007	Focus	2.3L	Crankshaft TDC Timing Pin	567622		303-507

Ford Tool Application Chart

Year	Model	Engine	Tool Description	Part No.	Ford American Part No.	Ford Global Part No.
2013-2014	Fusion	2.0L	Cam Alignment Tool Crankshaft TDC Timing Pin	6474 (511541) 6475 (511542)	T94P-6256-CH T97P-6000-A	303-465 303-574
2006-2009	Fusion	2.3L VIN Z	Cam Alignment Tool	6474 (511541)	T94P-6256-CH	303-465
2006-2009	Fusion	2.3L	Crankshaft TDC Timing Pin	567622		303-507
2010-2014	Fusion	2.5L VIN A	Cam Alignment Tool	6474 (511541)	T94P-6256-CH	303-465
2010-2014	Fusion	2.5L	Crankshaft TDC Timing Pin	567622		303-507
2010-2014	Fusion Hybrid	2.5L VIN 3	Cam Alignment Tool	6474 (511541)	T94P-6256-CH	303-465
2005-2008	Mariner	2.3L VIN Z	Cam Alignment Tool	6474 (511541)	T94P-6256-CH	303-465
2005-2008	Mariner	2.3L	Crankshaft TDC Timing Pin	567622		303-507
2009-2012	Mariner	2.5L VIN 7	Cam Alignment Tool	6474 (511541)	T94P-6256-CH	303-465
2009-2012	Mariner	2.5L	Crankshaft TDC Timing Pin	567622		303-507
2005-2008	Mariner Hybrid	2.3L VIN H	Cam Alignment Tool	6474 (511541)	T94P-6256-CH	303-465
2009-2012	Mariner Hybrid	2.5L VIN 3	Cam Alignment Tool	6474 (511541)	T94P-6256-CH	303-465
2006-2009	Milan	2.3L VIN Z	Cam Alignment Tool	6474 (511541)	T94P-6256-CH	303-465
2006-2009	Milan	2.3L	Crankshaft TDC Timing Pin	567622		303-507
2010-2011	Milan	2.5L	Cam Alignment Tool	6474 (511541)	T94P-6256-CH	303-465
2010-2012	Milan Hybrid	2.5L VIN 3	Cam Alignment Tool	6474 (511541)	T94P-6256-CH	303-465
2010-2011	Milan	2.5L	Crankshaft TDC Timing Pin	567622		303-507
2014	MKT	2.0L	Cam Alignment Tool Crankshaft TDC Timing Pin	6474 (511541) 6475 (511542)	T94P-6256-CH T97P-6000-A	303-465 303-574
2012	MKX	2.0L VIN 9	Cam Alignment Tool	6474 (511541)	T94P-6256-CH	303-465
2012	MKX	2.0L	Crankshaft TDC Timing Pin	567622		303-507
2013-2014	MKZ	2.0L	Cam Alignment Tool Crankshaft TDC Timing Pin	6474 (511541) 6475 (511542)	T94P-6256-CH T97P-6000-A	303-465 303-574
2006-2009	MKZ	2.3L VIN Z	Cam Alignment Tool	6474 (511541)	T94P-6256-CH	303-465
2006-2009	MKZ	2.3L	Crankshaft TDC Timing Pin	567622		303-507
2010-2012	MKZ	2.5L VIN A	Cam Alignment Tool	6474 (511541)	T94P-6256-CH	303-465
2010-2012	MKZ Hybrid	2.5L VIN 3	Cam Alignment Tool	6474 (511541)	T94P-6256-CH	303-465
2010-2012	MKZ	2.5L	Crankshaft TDC Timing Pin	567622		303-507
1994-2002	Mystique	2.0L 4 cyl. VIN 3	Cam Alignment Tool	6474 (511541)	T94P-6256-CH	303-465
1997-2002	Mystique	2.0L 4 cyl. VIN 3	Crankshaft TDC Timing Tool	6475 (511542)	T97P-6000-A	303-574
2001-2011	Ranger	2.3L VIN D	Cam Alignment Tool	6474 (511541)	T94P-6256-CH	303-465
2005-2011	Ranger	2.3L	Crankshaft TDC Timing Pin	567622		303-507
2013-2014	Taurus	2.0L	Cam Alignment Tool Crankshaft TDC Timing Pin	6474 (511541) 6475 (511542)	T94P-6256-CH T97P-6000-A	303-465 303-574
2010-2013	Transit	2.0L VIN N	Cam Alignment Tool Crankshaft TDC Timing Pin	6474 (511541) 6475 (511542)	T94P-6256-CH T97P-6000-A	303-465 303-574
2010-2012	Transit	2.0L	Crankshaft TDC Timing Pin	567622		303-507
2006-2009	Zephyr	2.3L VIN Z	Cam Alignment Tool	6474 (511541)	T94P-6256-CH	303-465
2006-2009	Zephyr	2.3L	Crankshaft TDC Timing Pin	567622		303-507

511541 (6474) Ford Camshaft Alignment Tool

Application: 1994 – 2002 2.0L 4 cyl. Contour, Mystique (VIN 3)
 1999 – 2002 2.0L Cougar (VIN 3)
 2012 – 2014 2.0L Edge, Explorer (VIN 9)
 2001 – 2004 2.0L Escape (VIN B)
 2013 – 2014 2.0L Escape (VIN 9), Fusion, MKZ, Taurus
 2005 – 2008 2.3L Escape, Mariner (VIN Z)
 2009 – 2014 2.5L Escape (VIN 7)
 2005 – 2008 2.3L Escape Hybrid, Mariner Hybrid (VIN H)
 2009 – 2012 2.5L Escape Hybrid, Mariner Hybrid (VIN 3)
 2012 – 2014 2.0L Focus (VIN 2)
 2000 – 2004 2.0L Focus (VIN 3)
 2002 – 2004 2.0L Focus (VIN 5)
 2005 – 2012 2.0L Focus (VIN N)
 2003 – 2007 2.3L Focus (VIN Z)
 2006 – 2009 2.3L Fusion, Milan, MKZ, Zephyr (VIN Z)
 2010 – 2014 2.5L Fusion (VIN A)
 2010 – 2014 2.5L Fusion Hybrid (VIN 3)
 2009 – 2012 2.5L Mariner (VIN 7)
 2010 – 2011 2.5L Milan
 2010 – 2012 2.5L Milan Hybrid, MKZ Hybrid (VIN 3)
 2014 2.0L MKT
 2012 2.0L MKX (VIN 9)
 2010 – 2012 2.5L MKZ (VIN A)
 2001 – 2011 2.3L Ranger (VIN D)
 2010 – 2013 2.0L Transit (VIN N)

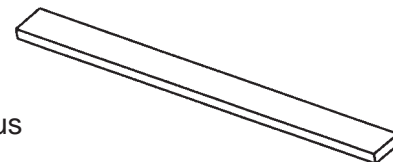

CAUTION: The Camshaft Alignment Tool is for camshaft alignment only. Using this tool to prevent rotation can result in engine damage.

NOTE:

- Same as Ford No. 303-465 (T94P-6256-CH).
- The camshaft timing slots are offset. If the camshaft alignment timing tool cannot be installed, rotate the crankshaft one complete revolution clockwise to correctly position the camshafts.

1. Rotate engine to top dead center on the No. 1 cylinder.
2. Align camshafts by installing tool No. 511541 (6474) into the slots at the rear of the camshafts as shown.
3. Service the timing belt as required according to instructions in the vehicle service manual.
4. Torque fasteners to factory specifications.
5. Remove the tool.

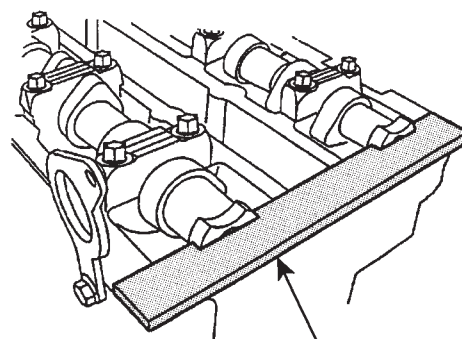

No. 511541
(6474)

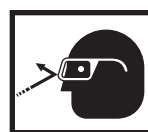

WARNING: Wear eye protection that meets ANSI Z87.1 and OSHA standards.

511542 (6475) Ford Crankshaft TDC Timing Pin

Application: 1997 – 2002 2.0L 4 cyl. Contour, Mystique (VIN 3)
 1999 – 2002 2.0L Cougar (VIN 3)
 2012 – 2014 2.0L Edge, Explorer (VIN 9)
 2001 – 2004 2.0L Escape (VIN B)
 2013 – 2014 2.0L Escape (VIN 9), Fusion, MKZ, Taurus
 2012 – 2014 2.0L Focus (VIN 2)
 2000 – 2004 2.0L Focus (VIN 3)
 2002 – 2004 2.0L Focus (VIN 5)
 2005 – 2011 2.0L Focus (VIN N)
 2014 2.0L MKT
 2010 – 2013 2.0L Transit (VIN N)

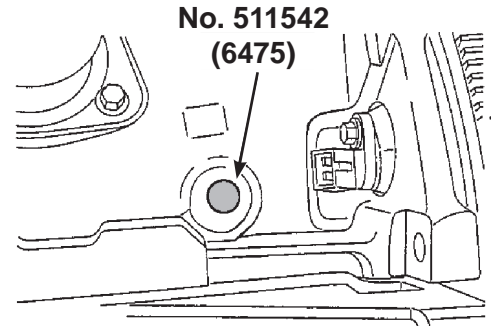
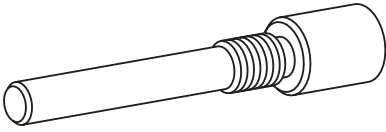

CAUTION: To prevent damage to the engine, remove the No. 511542 (6475) timing pin from the engine and reinstall the access plug **BEFORE** cranking the engine.

1. Rotate crankshaft to set No. 1 cylinder on TDC of compression stroke.
2. Remove the access plug from the engine and install tool No. 511542 (6475) timing pin as shown. (The pin will completely thread into the hole when the engine is at TDC on the No. 1 cylinder.)
3. Service the timing belt as required according to vehicle service manual procedures.
4. Torque fasteners to factory specifications.

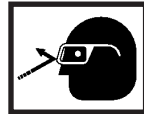

WARNING: Wear eye protection that meets ANSI Z87.1 and OSHA standards.

567622 Ford Crankshaft TDC Timing Pin

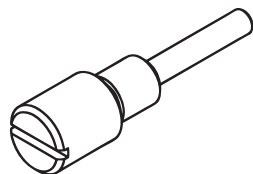

Application:	2012	2.0L	Edge, MKX
	2005 – 2008	2.3L	Escape, Mariner
	2009 – 2012	2.5L	Escape, Mariner
	2005 – 2012	2.0L	Focus
	2005 – 2007	2.3L	Focus
	2006 – 2009	2.3L	Fusion, Milan, MKZ, Zephyr
	2010 – 2014	2.5L	Fusion
	2010 – 2011	2.5L	Milan
	2010 – 2012	2.5L	MKZ
	2005 – 2011	2.3L	Ranger
	2010 – 2012	2.0L	Transit

NOTE: The 567622 Crankshaft TDC Timing Pin will contact the crankshaft and prevent it from turning past TDC. However, the crankshaft can still be rotated in the counterclockwise direction. The crankshaft must remain at the TDC position during the crankshaft pulley removal and installation.

1. Remove engine plug bolt.

NOTE: Rotate the crankshaft in the clockwise direction only.

2. Install the 567622 Crankshaft TDC Timing Pin in the hole. Rotate crankshaft until it makes contact with the 567622 Crankshaft TDC Timing Pin.
3. Perform crankshaft or timing service as required according to vehicle service manual.

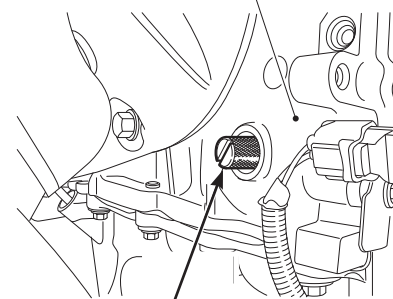
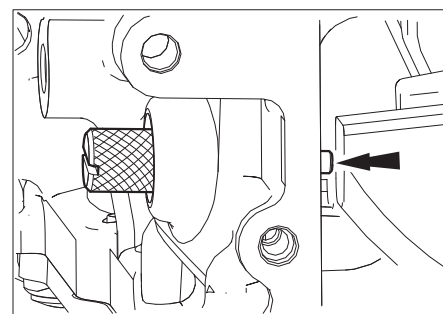

No. 567622



! WARNING: Wear eye protection that meets ANSI Z87.1 and OSHA standards.