

## Ford Camshaft Alignment Tool

Application: 1994 – 2002 2.0L 4 cyl. Contour, Mystique (VIN 3)  
 1999 – 2002 2.0L Cougar (VIN 3)  
 2012 – 2014 2.0L Edge, Explorer (VIN 9)  
 2001 – 2004 2.0L Escape (VIN B)  
 2013 – 2014 2.0L Escape (VIN 9), Fusion, MKZ, Taurus  
 2005 – 2008 2.3L Escape, Mariner (VIN Z)  
 2009 – 2014 2.5L Escape (VIN 7)  
 2005 – 2008 2.3L Escape Hybrid, Mariner Hybrid (VIN H)  
 2009 – 2012 2.5L Escape Hybrid, Mariner Hybrid (VIN 3)  
 2012 – 2014 2.0L Focus (VIN 2)  
 2000 – 2004 2.0L Focus (VIN 3)  
 2002 – 2004 2.0L Focus (VIN 5)  
 2005 – 2012 2.0L Focus (VIN N)  
 2003 – 2007 2.3L Focus (VIN Z)  
 2006 – 2009 2.3L Fusion, Milan, MKZ, Zephyr (VIN Z)  
 2010 – 2014 2.5L Fusion (VIN A)  
 2010 – 2014 2.5L Fusion Hybrid (VIN 3)  
 2009 – 2012 2.5L Mariner (VIN 7)  
 2010 – 2011 2.5L Milan  
 2010 – 2012 2.5L Milan Hybrid, MKZ Hybrid (VIN 3)  
 2014 2.0L MKT  
 2012 2.0L MKX (VIN 9)  
 2010 – 2012 2.5L MKZ (VIN A)  
 2001 – 2011 2.3L Ranger (VIN D)  
 2010 – 2013 2.0L Transit (VIN N)

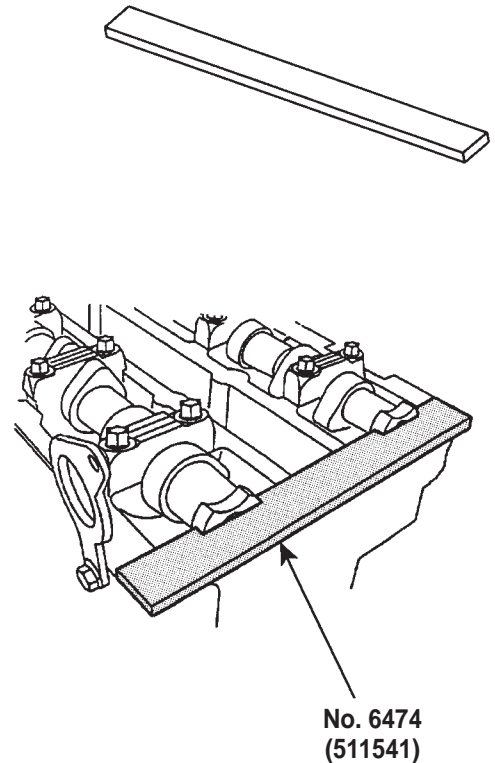

**NOTE:**

- Same as Ford No. 303-465 (T94P-6256-CH).
- The camshaft timing slots are offset. If the camshaft alignment timing tool cannot be installed, rotate the crankshaft one complete revolution clockwise to correctly position the camshafts.

**CAUTION: The Camshaft Alignment Tool is for camshaft alignment only. Using this tool to prevent rotation can result in engine damage.**

1. Rotate engine to top dead center on the No. 1 cylinder.
2. Align camshafts by installing tool No. 6474 (511541) into the slots at the rear of the camshafts as shown.
3. Service the timing belt as required according to instructions in the vehicle service manual.
4. Torque fasteners to factory specifications.
5. Remove the tool.