

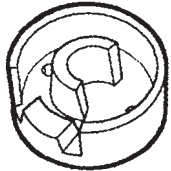

Operating Instructions
for:

6469
(511536)

Ford Camshaft Sensor Synchronizer Tool



Application:	1997	3.8L V6 Cougar, Thunderbird
	1997 – 2008	4.2L V6 Econoline, F-Series Truck
	1996 – 1998	5.0L V8 Ford Explorer, Mercury Mountaineer
	2004 – 2007	4.2L Freestar, Monterey
	1996 – 1998	3.8L V6 Mustang, Windstar

NOTE: Same as Ford No. 303-562 (T96T-12200-A).

CAUTION: Before removing the camshaft sensor housing assembly, note the position of the camshaft sensor electrical connector. To prevent equipment damage, the connector **MUST** be reassembled in the same position during installation.

1. Rotate crankshaft to set No. 1 cylinder at top dead center of the compression stroke.
2. Engage camshaft sensor housing vane in slot of tool No. 6469 (511536).
3. Rotate tool on camshaft sensor housing until tool engages housing notch. (Tool should be square and in contact with entire top of housing.)
4. Install camshaft sensor housing and tool assembly into engine according to instructions in the vehicle service manual. Torque fasteners to factory specifications.

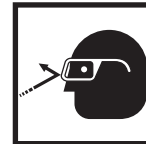
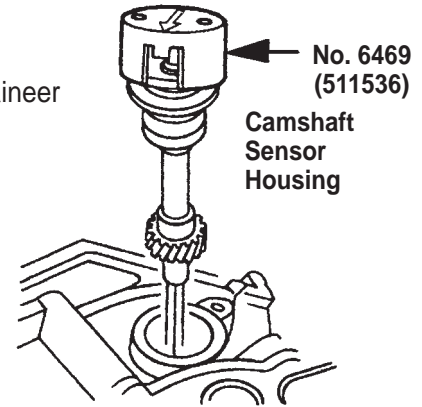

WARNING: Wear eye protection that meets ANSI Z87.1 and OSHA standards.